



Distributor of Texas Instruments: Excellent Integrated System Limited

Datasheet of CI2EVMBOC - BREAKOUT CARDS

Contact us: sales@integrated-circuit.com Website: www.integrated-circuit.com

Excellent Integrated System Limited

Stocking Distributor

Click to view price, real time Inventory, Delivery & Lifecycle Information:

[Texas Instruments](#)
[CI2EVMBOC](#)

For any questions, you can email us directly:

sales@integrated-circuit.com



Dual EVM Breakout Card: Quick Setup Guide

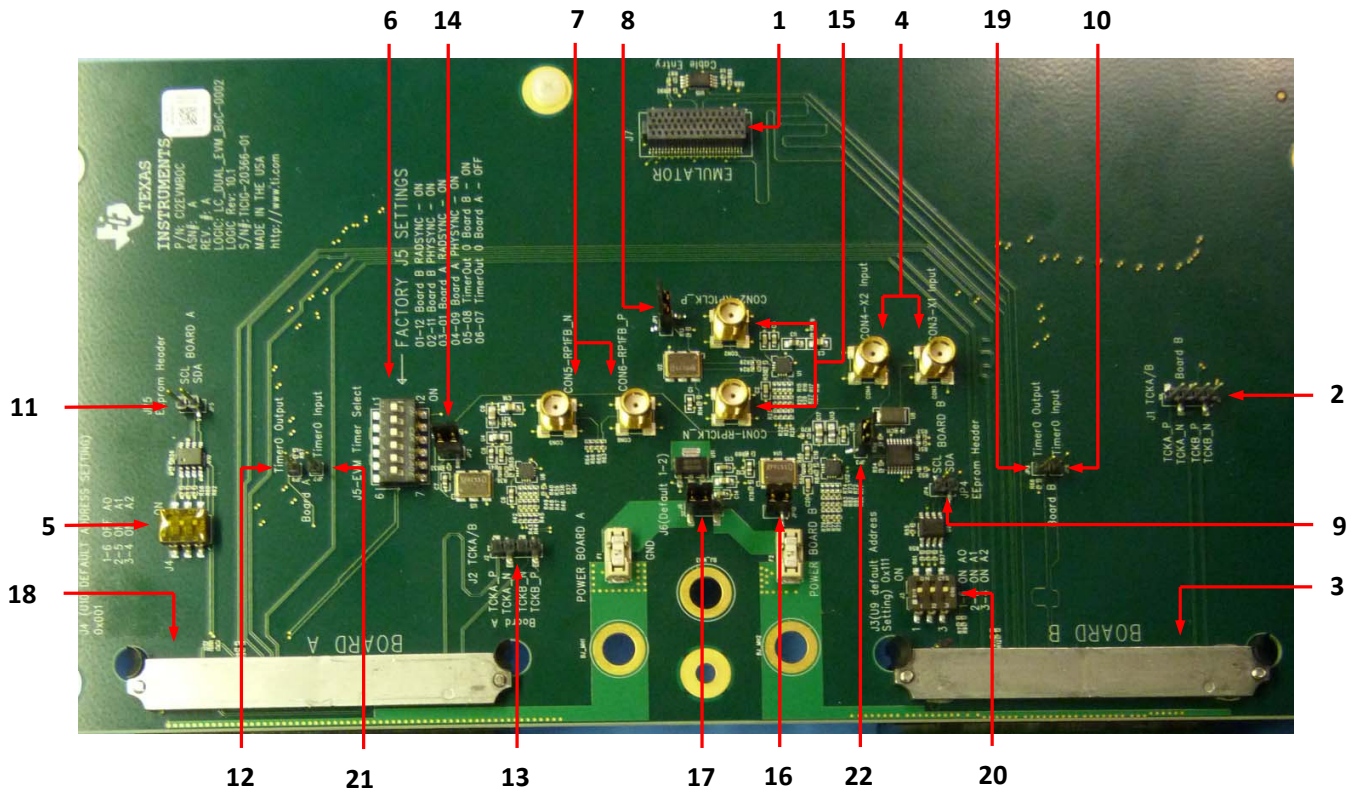

- | | |
|---|---|
| <ul style="list-style-type: none"> 1 - Emulation Interface – J7 2 - Board B TCKA/B Header – J1 3 - Board B AMC B+ EVM Interface Connector 4 - Auxiliary PCIe Clock Input SMA Connectors - CON3/CON4 5 - Board A EEPROM Address Configuration Switch - J4 6 - Timer Sync Configuration Switch - J5 7 - Auxiliary RP1FB Clock Input SMA Connectors – CON5/CON6 8 - RP1CLK Source Input Clock Oscillator Enable Control – JP1 9 - Board B I2C EEPROM Programming Header – JP4 10 - Board B Timer0 Input Interface Header – JP6 11 - Board A I2C EEPROM Programming Header – JP5 | <ul style="list-style-type: none"> 12 - Board A Timer0 Output Interface Header – JP9 13 - Board A TCKA/B Header – J2 14 - A_TCLKB & B_TCKB Source Input Clock Oscillator Enable Control – JP2 15 - Auxiliary RP1CLK Clock Input SMA Connectors – CON1/CON2 16 - Board A & B REFCLK Source Input Clock Oscillator Enable Control – JP10 17 - Primary BoC Power Selection Switch – J6 18 - Board A AMC B+ EVM Interface Connector 19 - Board B Timer0 Output Interface Header – JP8 20 - Board B EEPROM Address Configuration Switch – J3 21 - Board A Timer0 Input Interface Header – JP7 22 - Board A & B PCIECLK Source Input Clock Oscillator Enable Control - JP3 |
|---|---|

Two TCI6618 EVMs with Break Out Card Setup

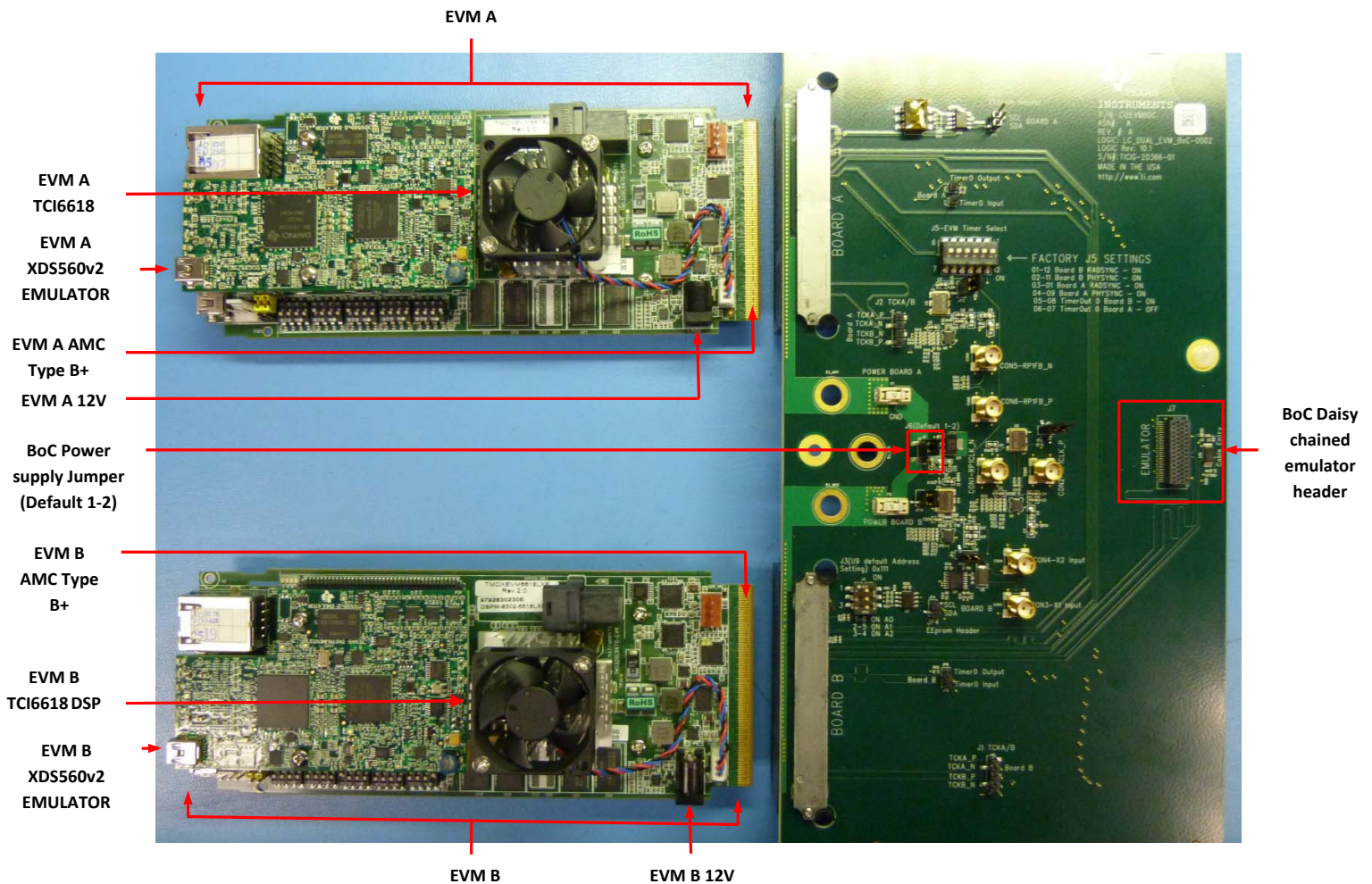

The EVM dual Break Out Card (BOC) is a high performance inter-communication card designed to provide 2 EVMs to communicate across their high speed interfaces. Out of the box the BoC supports EVM to EVM communication for: SRIO, SGMII, and PCI express. In addition, each EVM will need power and emulation provided.

For EVM to EVM communication using AIF2 and the other supported features of the BOC, please refer to Texas Instruments Dual EVM BoC Card – User’s Guide (refer to the Wiki link given below). A list of supported EVMs will also be listed at the following website:

http://processors.wiki.ti.com/index.php/CI_Dual_EVM_Break_Out_Card

NOTE: While the BOC has an emulation header to support JTAG daisy for the SOC’s on the EVMs, the XDS560v2 mezzanine cards must be removed from the EVMs in order for the BOC emulation header to operate correctly.