

Excellent Integrated System Limited

Stocking Distributor

Click to view price, real time Inventory, Delivery & Lifecycle Information:

[JKL Components Corporation](#)
[BXA-12553](#)

For any questions, you can email us directly:
sales@integrated-circuit.com

REV.	DESCRIPTION/ECO NO.	DATE
	RELEASE & CANCEL	1/3/03
	BXA-12553/KIT & BXA-12553/INV	

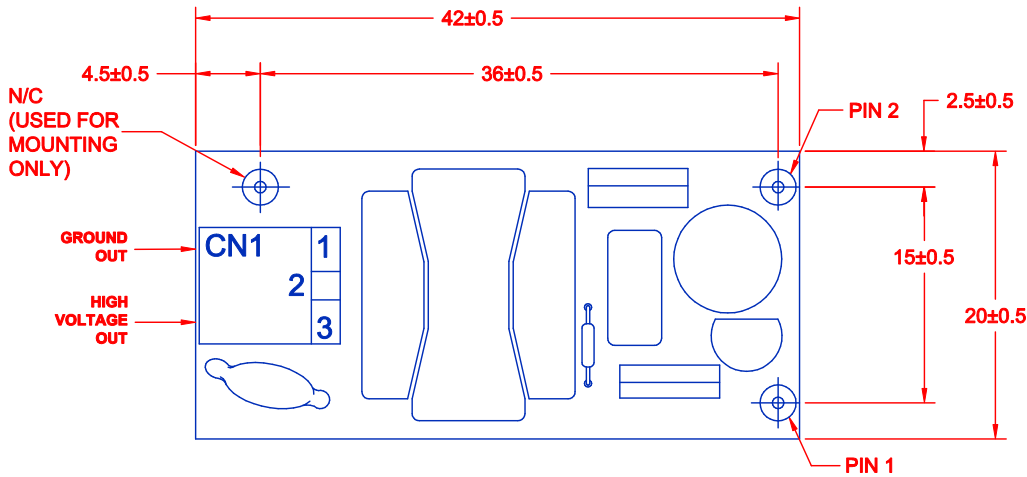

NOTE:
MATING CONNECTOR IS NOT INCLUDED WITH INVERTER. JKL WIRE HARNESS PART NO. BXC-10566 CAN BE ORDERED SEPARATELY.

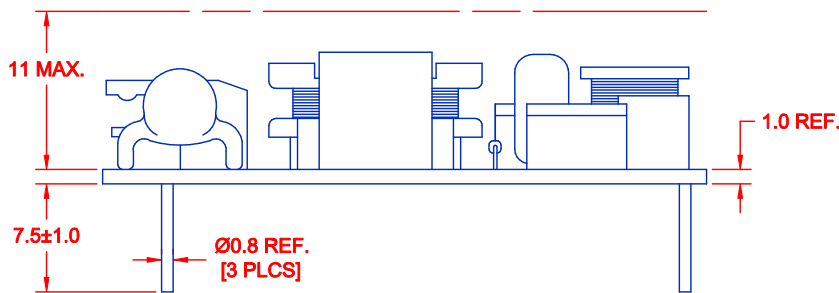

CN1 PIN #	TO LAMP
1	OUT GROUND
2	N/C
3	HIGH V

BOARD PIN #	INPUT
1	+V (V in)
2	V (GND)

CHARACTERISTICS	MIN	TYP	MAX
INPUT VOLTAGE: (vdc)	10.8	12.0	13.2
INPUT CURRENT: (mA)	---	180	250
OUTPUT VOLTAGE: (Vrms)	600	700	800
OUTPUT CURRENT (maRms)	4.0	5.5	7.0
OUTPUT FREQUENCY: (kHz)	10	25	40
OPERATING TEMP: (CELSIUS)	0	25	50

METRIC		DIMENSIONS ARE IN MILLIMETERS		JKL COMPONENTS CORPORATION				
THIRD ANGLE PROJECTION		TOLERANCE UNLESS OTHERWISE SPECIFIED		TITLE				
		1 PL +/- 0.3		CCFL POWER SUPPLY				
		2 PL +/- ANGLE +/- 0		DRAWING NO. BXA-12553				
DRAWN BY	APPVD BY	DATE	SIZE	FSCM NO.	SCALE			
L. WENGSTROM	F.D.	1/3/03	A	55335	NONE			
- CAD DRAWING -				RELEASED DATE	1/3/03	REVISION DATE	REV. NO.	SHEET OF
MANUAL REVISIONS NOT PERMITTED								