

Excellent Integrated System Limited

Stocking Distributor

Click to view price, real time Inventory, Delivery & Lifecycle Information:

[Hammond Manufacturing](#)
[1590FFL](#)

For any questions, you can email us directly:

sales@integrated-circuit.com

Top View of Assembly

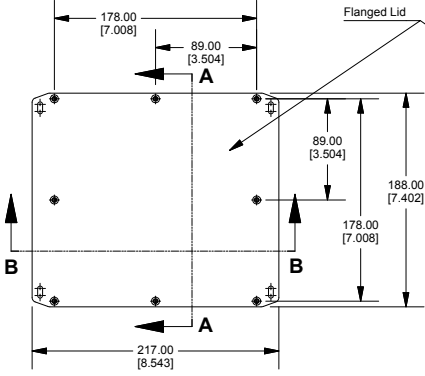

**SECTION A-A
End View of Assembly**

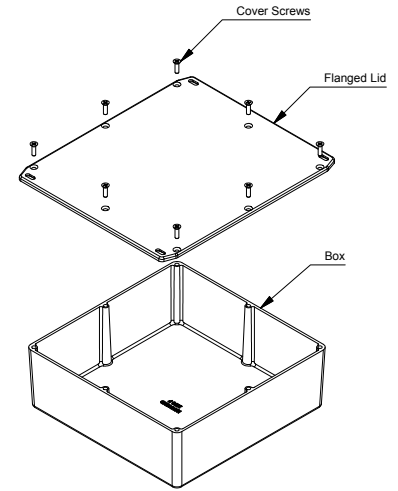
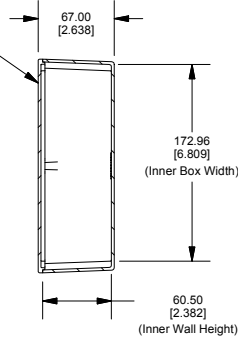

**SECTION B-B
Side View of Assembly**

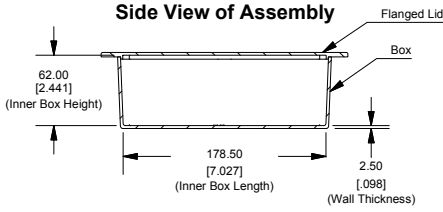

Top View Looking Inside Box

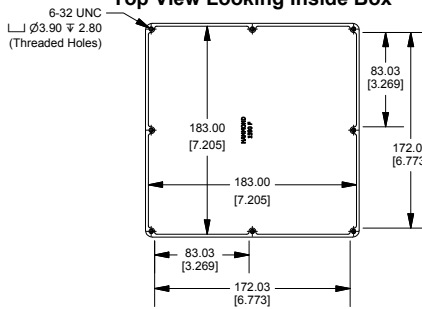

Flanged Lid

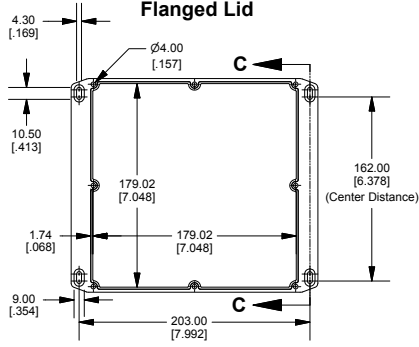

**SECTION C-C
Side View of Slot**

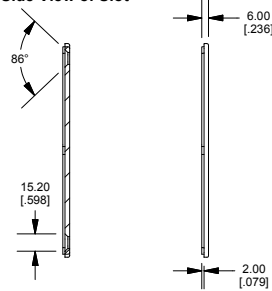

Enclosures can be Factory Modified (Milling, Drilling, Printing etc.)
Contact Factory mjm@hammondmfg.com for quotes
Solid models of this enclosure available in STEP or IGES.

NOTE

Purchased assembly includes box, lid and 8 cover screws.
Box and lid are made from Diecast Aluminum Alloy.
Silicone Gasket supplied with liquid resistant enclosure.

PART NUMBERS

1590FFL Enclosure	
Natural Finish Enclosure	1590FFL
Black Textured Enclosure	1590FFLBK
1590FFL Liquid Resistant Enclosure (Silicone Gasket)	
Natural Finish Enclosure	1590W FFL
Black Textured Enclosure	1590W FFLBK
ACCESSORIES	
Recommended Torque: 75 ozf.in / 55 cN.m	
Liquid Resistant Cover Screws	
Stainless Steel Cover Screws (Pkg 100)	1590W MS100
Black Stainless Steel Cover Screws (Pkg 100)	1590W MS100BK
Standard Cover Screws	
Plated Cover Screws (Pkg 100)	1590MS100
Black Cover Screws (Pkg 100)	1590MS100BK

Dimensions:
mm
[inches]

**HAMMOND
MANUFACTURING™**

1590FFL

www.hammondmfg.com