

Excellent Integrated System Limited

Stocking Distributor

Click to view price, real time Inventory, Delivery & Lifecycle Information:

[Hammond Manufacturing](#)
[1590Z160](#)

For any questions, you can email us directly:

sales@integrated-circuit.com

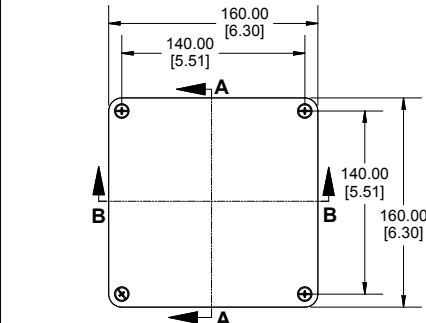

TOP VIEW

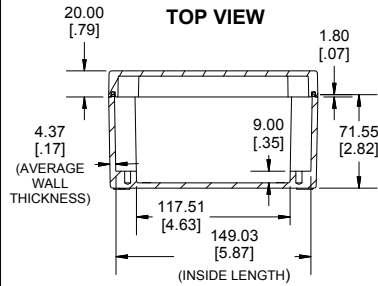

**SECTION B-B
SIDE VIEW**

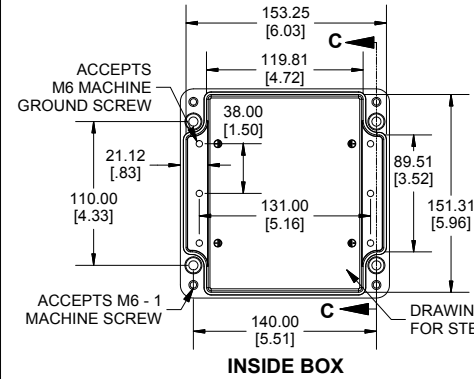

INSIDE BOX

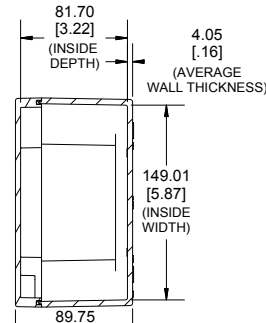

**SECTION A-A
END VIEW**

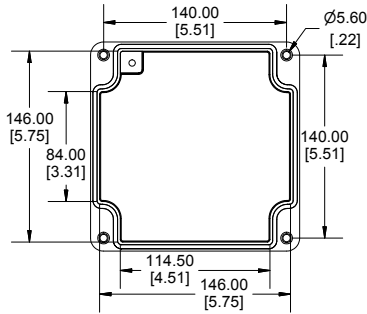

INSIDE LID

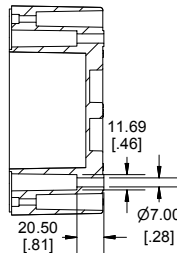

**SECTION C-C
MOUNTING HOLE**

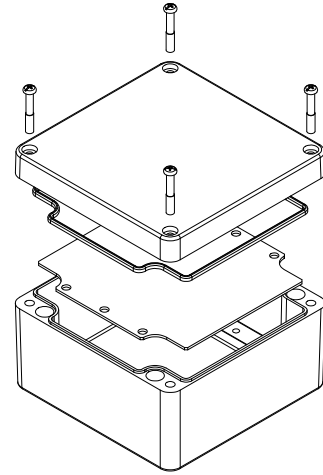

Enclosures can be Factory Modified (Milling, Drilling, Printing etc.)
Contact Factory mjm@hammondmfg.com for quotes
Solid models of this enclosure available in STEP or IGES.
(Part number and text placement/orientation on our products are subject to change.
We do not recommend using them as a locating reference for modification purposes)

NOTE	
Purchased assembly includes box, lid, silicone gasket, 4 cover screws and 4 ground screws with washers. Box and lid are made from Diecast Aluminum Alloy.	
Recommended cover screw Torque 15-17 lbf.in (150 -170 cN.m)	

1590Z160	
1590Z160 Enclosure	
Basic Enclosure	1590Z160
Black Enclosure	1590Z160BK
Grey Enclosure - RAL7001 Gloss	1590Z160GY
ACCESSORIES	
Steel Inner Panel	1590Z160PL
Pre-Formed Silicone Gasket	1590Z160G
Copper Ground Hardware (4 Pack) [M6 - 1.0 X 10mm / M6 Washer]	SCGM6

**HAMMOND
MANUFACTURING.**

1590Z160

www.hammondmfg.com

Dimensions:
mm
[inches]