

## Excellent Integrated System Limited

Stocking Distributor

Click to view price, real time Inventory, Delivery & Lifecycle Information:

[Texas Instruments](#)  
[PCM1710U/1K](#)

For any questions, you can email us directly:

[sales@integrated-circuit.com](mailto:sales@integrated-circuit.com)



**PCM1710U**

*Sound PLUS* Stereo Audio  
**DIGITAL-TO-ANALOG CONVERTER**

**FEATURES**

- **COMPLETE STEREO DAC:**  
8X Oversampling Digital Filter  
Multi-Level Delta-Sigma DAC  
Analog Low Pass Filter  
Output Amplifier
- **HIGH PERFORMANCE:**  
-92dB THD+N  
98dB Dynamic Range  
110dB SNR
- **ACCEPTS 16 OR 20 BITS INPUT DATA**
- **SYSTEM CLOCK: 256fs or 384fs**
- **SINGLE +5V POWER SUPPLY**
- **ON-CHIP DIGITAL FILTER:**  
Soft Mute and Attenuator  
Digital De-emphasis  
Double-Speed Dubbing Mode
- **SMALL 28-PIN SOIC PACKAGE**

**DESCRIPTION**

The PCM1710 is a complete stereo audio digital-to-analog converter, including digital interpolation filter, delta-sigma DAC, and analog voltage output. PCM1710 can accept either 16-bit normal or 20-Bit normal input data (MSB first, right justified), or 16-bit IIS data (32-bits per word, continuous clock).

The digital filter performs an 8X interpolation function, as well as special functions such as soft mute, digital attenuation, de-emphasis and double-speed dubbing. Performance of the digital feature is excellent, featuring -62dB stop band attenuation and ±0.008dB ripple in the pass band.

PCM1710 is suitable for a wide variety of consumer applications where good performance is required. Its low cost, small size and single +5V power supply make it ideal for automotive CD players, bookshelf CD players, BS tuners, keyboards, MPEG audio, MIDI applications, set-top boxes, CD-ROM drives, CD-Interactive and CD-Karaoke systems.

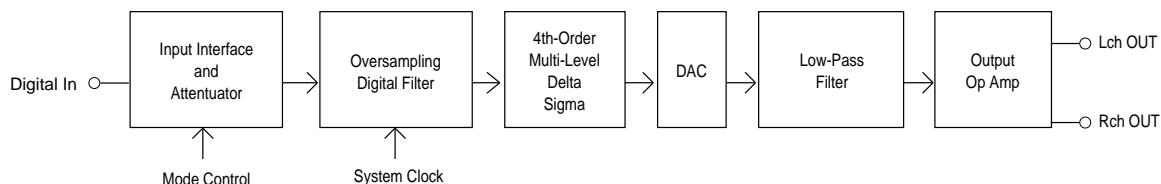

International Airport Industrial Park • Mailing Address: PO Box 11400 • Tucson, AZ 85734 • Street Address: 6730 S. Tucson Blvd. • Tucson, AZ 85706  
Tel: (520) 746-1111 • Twx: 910-952-1111 • Cable: BBRCORP • Telex: 066-6491 • FAX: (520) 889-1510 • Immediate Product Info: (800) 548-6132

## SPECIFICATIONS

All specifications at +25°C, +V<sub>CC</sub> = +V<sub>DD</sub> = +5V, f<sub>S</sub> = 44.1kHz, f<sub>sys</sub> = 384/256fs, and 16-bit data, unless otherwise noted.

PARAMETER	CONDITIONS	PCM1710U			UNITS
		MIN	TYP	MAX	
<b>RESOLUTION</b>		16		20	Bits
<b>DIGITAL INPUT</b>					
Logic Family					
Input Logic Level (except XT1)		2.0		0.8	VDC
V <sub>IH</sub>					VDC
V <sub>IL</sub>				-200	μA
Input Logic Current (except XT1)					
Input Logic Level (XT1)		3.2		1.4	VDC
V <sub>IH</sub>					VDC
V <sub>IL</sub>				±50	μA
Input Logic Current (XT1)					
Output Logic Level (CLKO):		4.5		0.5	VDC
V <sub>OH</sub>					VDC
V <sub>OL</sub>					mA
Output Logic Current (CLKO)		±10			
Data Format	Normal (16/20-bit)/IIS (16-bit) selectable				
Sampling Frequency		32	44.1	48	kHz
System Clock Frequency	384f <sub>S</sub>	12.288	16.934	18.432	MHz
System Clock Frequency	256f <sub>S</sub>	8.192	11.2894	12.288	MHz
<b>DC ACCURACY</b>					
Gain Error			±1.0	±5.0	% of FSR
Gain Mis-Match Channel-To-Channel			±1.0	±5.0	% of FSR
Bipolar Zero Error	V <sub>O</sub> = 1/2V <sub>CC</sub> at Bipolar Zero		±20.0		mV
Gain Drift			±50		ppm of FSR/°C
Bipolar Gain Drift			±20		ppm of FSR/°C
<b>DYNAMIC PERFORMANCE<sup>(1)</sup></b>					
THD+N at F/S (0dB) <sup>(2)</sup>	f <sub>IN</sub> = 991kHz		-92	-88	dB
THD+N at -60dB <sup>(2)</sup>	f <sub>IN</sub> = 991kHz		-36	-32	dB
Dynamic Range	EIAJ A-weighted		98		dB
S/N Ratio	EIAJ A-weighted	104	110		dB
Channel Separation		90	94		dB
<b>DIGITAL FILTER PERFORMANCE</b>					
Pass Band Ripple	Normal Mode			±0.008	dB
Pass Band Ripple	Double Speed Mode			±0.018	dB
Stop Band Attenuation	Normal Mode	-62			dB
Stop Band Attenuation	Double Speed Mode	-58			dB
Pass Band	Normal Mode			0.4535	fs
Pass Band	Double Speed Mode			0.4535	fs
Stop Band	Normal Mode			0.5465	fs
Stop Band	Double Speed Mode			0.5465	fs
De-emphasis Error	(f <sub>S</sub> 32kHz ~ 48kHz)	-0.05		+0.03	dB
<b>ANALOG OUTPUT</b>					
Voltage Range		5	3.2		Vp-p
Load Impedance					kΩ
Center Voltage			+1/2V <sub>CC</sub>		V
<b>POWER SUPPLY REQUIREMENTS</b>					
Voltage Range: +V <sub>CC</sub>		+4.5	+5.0	+5.5	VDC
+V <sub>DD</sub>		+4.5	+5.0	+5.5	VDC
Supply Current (+I <sub>CC</sub> ) + (+I <sub>DD</sub> )			45	70	mA
<b>TEMPERATURE RANGE</b>					
Operation		-25		+85	°C
Storage		-55		+100	°C

NOTE: (1) Dynamic performance specs are tested with external 20kHz low pass filter. (2) 30kHz LPF, 400Hz HPF, Average Mode. Shibusoku #725 THD Meter.

The information provided herein is believed to be reliable; however, BURR-BROWN assumes no responsibility for inaccuracies or omissions. BURR-BROWN assumes no responsibility for the use of this information, and all use of such information shall be entirely at the user's own risk. Prices and specifications are subject to change without notice. No patent rights or licenses to any of the circuits described herein are implied or granted to any third party. BURR-BROWN does not authorize or warrant any BURR-BROWN product for use in life support devices and/or systems.

### PIN ASSIGNMENTS

PIN NAME	NUMBER	FUNCTION
<b>Input Interface Pins</b>		
LRCIN	1	Sample Rate Clock Input. Controls the update rate (fs).
DIN	2	Serial Data Input. MSB first, right justified format contains a frame of 16-bit or 20-bit data.
BCKIN	3	Bit Clock Input. Clocks in the data present on DIN input.
<b>Mode Controls and Clock Signals</b>		
CLKO	4	Buffered Output of Oscillator. Equivalent to fs.
XTI	5	Oscillator Input (External Clock Input). For an internal clock, tie XTI to one side of the crystal oscillator. For an external clock, tie XTI to the output of the chosen external clock.
XTO	6	Oscillator Output. When using the internal clock, tie to the opposite side (from pin 5) of the crystal oscillator. When using an external clock, leave XTO open.
CKSL	23	System Clock Select. For 384fs, tie CKSL "High". For 256fs, tie CKSL "Low".
MODE	24	Operation Mode Select. For serial mode, tie MODE "High". For parallel mode, tie MODE "Low".
MUTE	25	Mute Control. To disable soft mute, tie MUTE "High". To enable soft mute, tie MUTE "Low".
MD/DM1	26	Mode Control for Data/De-emphasis. See "Mode Control Functions" on page 11.
MC/DM2	27	Mode Control for BCKIN/De-emphasis. See "Mode Control Functions" on page 11.
ML/DSD	28	Mode Control for WDCK/Double speed dubbing. See "Mode Control Functions" on page 11.
<b>Analog Functions</b>		
V <sub>OUTR</sub>	13	Right Channel Analog Output.
V <sub>OUTL</sub>	16	Left Channel Analog Output.
<b>Power Supply Connections</b>		
DGND	7, 22	Digital Ground.
V <sub>DD</sub>	8, 21	Digital Power Supply (+5V).
V <sub>CC2R</sub>	9	Analog Power Supply (+5V), Right Channel DAC.
AGND2R	10	Analog Ground (DAC), Right Channel.
EXT1R	11	Output Amplifier Common, Right Channel. Bypass to ground with a 10µF capacitor.
EXT2R	12	Output Amplifier Bias, Right Channel. Connect to EXT1R.
AGND	14	Analog Ground.
V <sub>CC</sub>	15	Analog Power Supply (+5V).
EXT2L	17	Output Amplifier Bias, Left Channel. Connect to EXT1L.
EXT1L	18	Output Amplifier Common, Left Channel. Bypass to ground with a 10µF capacitor.
AGND2L	19	Analog Ground (DAC), Left Channel.
V <sub>CC2L</sub>	20	Analog Power Supply (+5V), Left Channel DAC.

### ABSOLUTE MAXIMUM RATINGS

Power Supply Voltages .....	±6.5VDC
+V <sub>CC</sub> to V <sub>DD</sub> Voltage .....	±0.1V
Input Logic Voltage .....	-0.3V to V <sub>DD</sub> +0.3V
Power Dissipation .....	400mW
Operating Temperature Range .....	-25°C to +85°C
Storage Temperature Range .....	-55°C to +125°C
Lead Temperature (soldering, 5s) .....	+260°C

### PACKAGE INFORMATION

MODEL	PACKAGE	PACKAGE DRAWING NUMBER <sup>(1)</sup>
PCM1710U	28-Pin SOIC	217

NOTE: (1) For detailed drawing and dimension table, please see end of data sheet, or Appendix D of Burr-Brown IC Data Book.

**PIN CONFIGURATION**

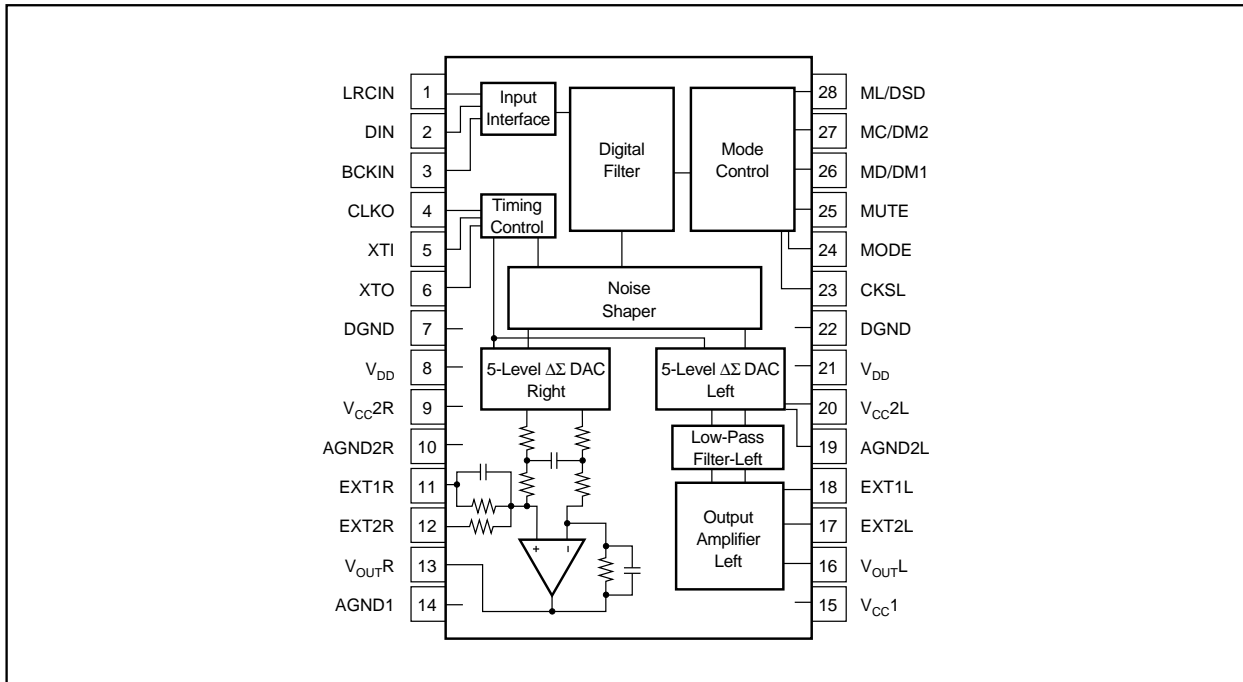

**CONNECTION DIAGRAM**

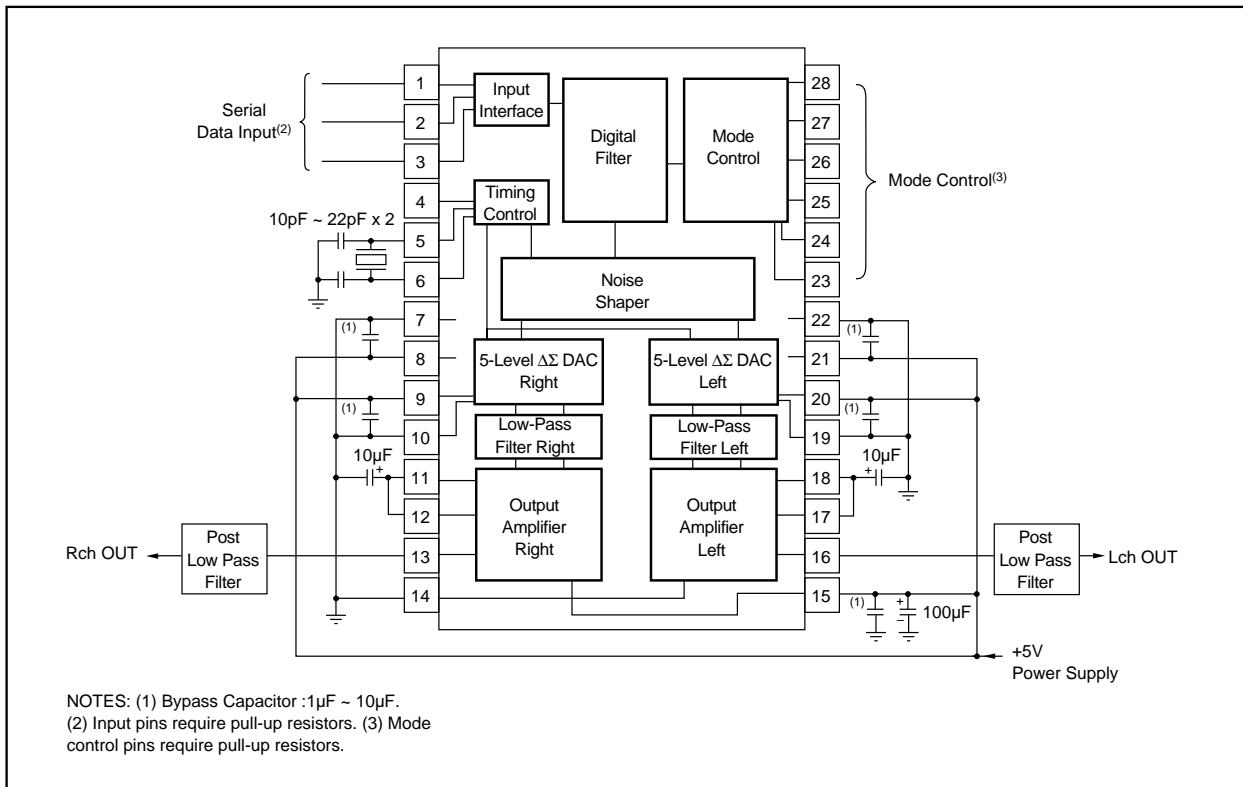

## DATA INPUT TIMING

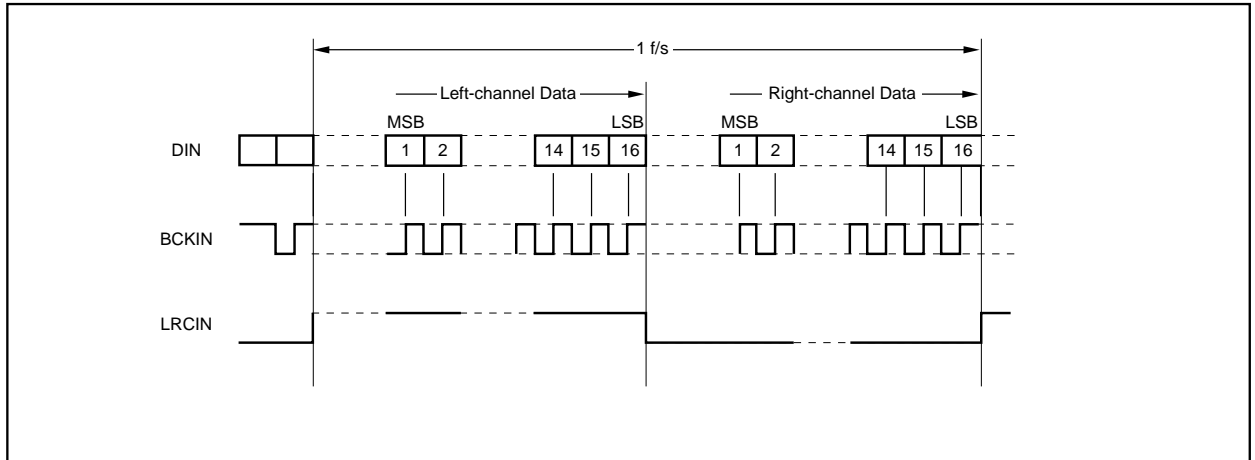

FIGURE 1. Normal Format, 16-Bit (LRCIN H: Lch).

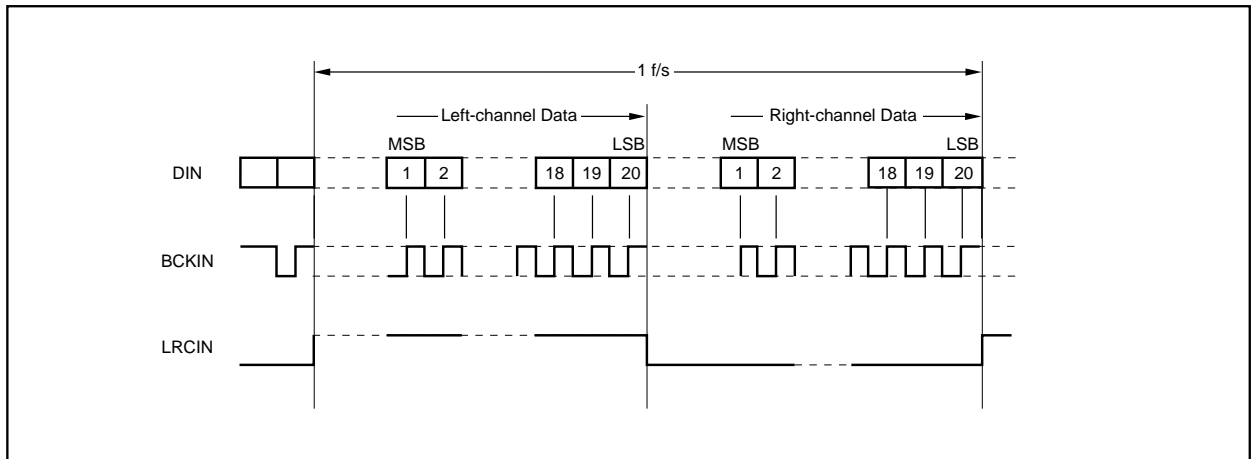

FIGURE 2. Normal Format, 20-Bit (LRCIN H: Lch).

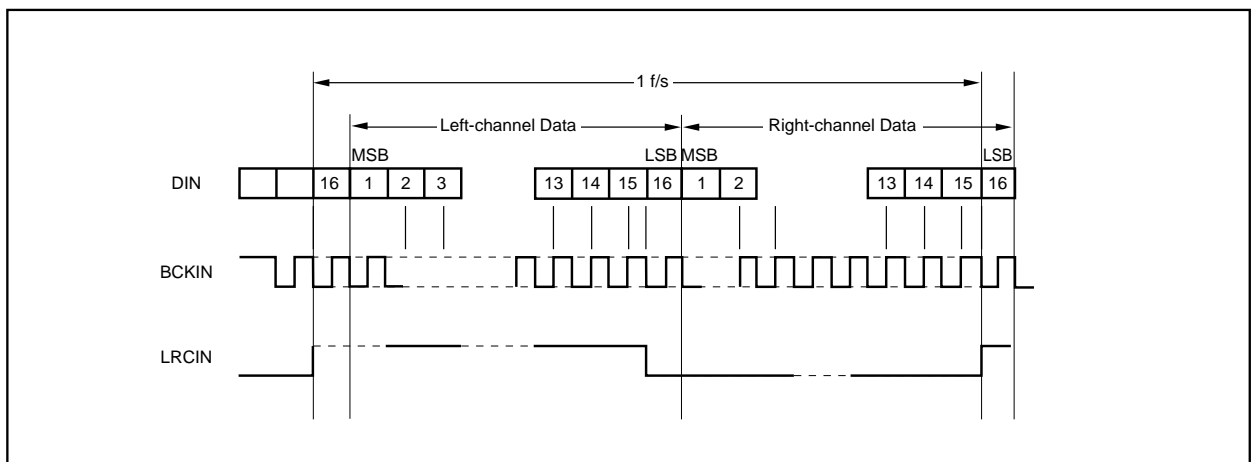

FIGURE 3. IIS Format, (16-Bit, 32 BCKIN Clock Cycles Per fs Interval).

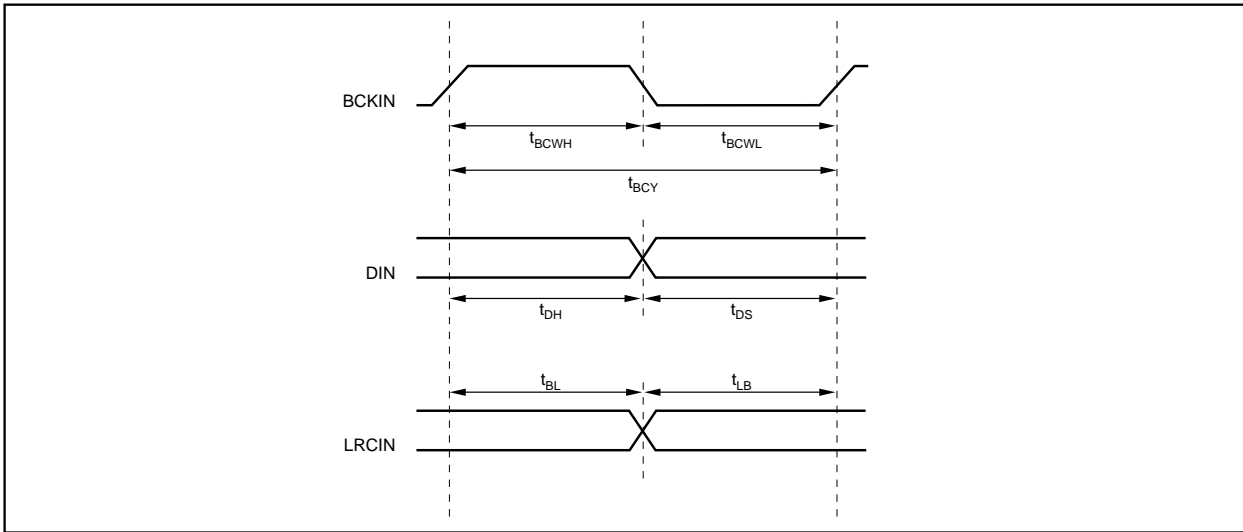

FIGURE 4. Data Input Timing.

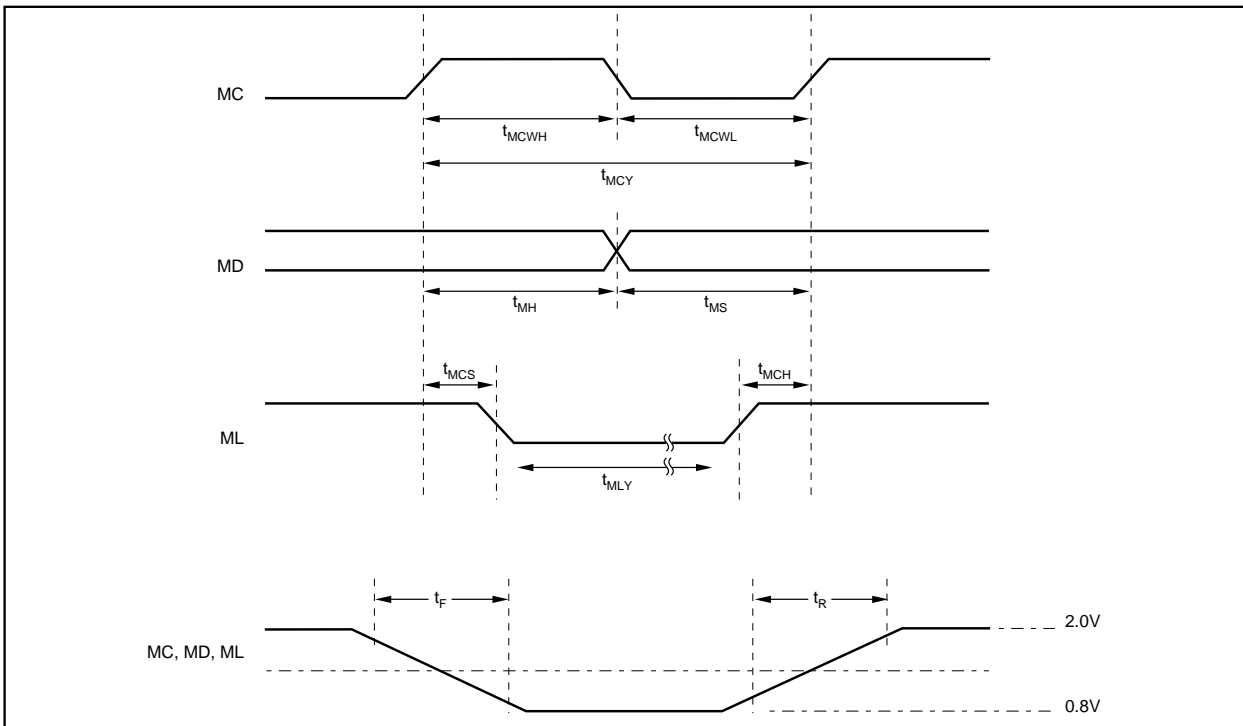

FIGURE 5. Serial Mode Control Timing.

BCK Pulsewidth (H Level)	$t_{BCWH}$	70ns (min)
BCK Pulsewidth (L Level)	$t_{BCWL}$	70ns (min)
BCK Pulse Cycle Time	$t_{BCY}$	140ns (min)
DIN Setup Time	$t_{DS}$	30ns (min)
DIN Hold Time	$t_{DH}$	30ns (min)
BCK Rising Edge → LRCI Edge	$t_{BL}$	30ns (min)
LRC I Edge → BCK Rising Edge	$t_{LB}$	30ns (min)

TABLE I. Data Input Timing Specifications (Refer to Figure 4).

MC Pulsewidth (H Level)	$t_{MCWH}$	50ns (min)
MC Pulsewidth (L Level)	$t_{MCWL}$	50ns (min)
MC Pulse Cycle Time	$t_{MCY}$	100ns (min)
MD Setup Time	$t_{MS}$	30ns (min)
MD Hold Time	$t_{MH}$	30ns (min)
ML Setup Time	$t_{MCS}$	30ns (min)
ML Hold Time	$t_{MCH}$	30ns (min)
ML Low-Level Time	$t_{MLY}$	$1/\text{sysclk} + 20\text{ns (min)}$
MC, MD, ML Rise Time	$t_R$	15ns (max)
MC, MD, ML Fall Time	$t_F$	15ns (max)

TABLE II. Serial Mode Control Timing Specifications (Refer to Figure 5).

## TYPICAL PERFORMANCE CURVES

All specifications at +25°C, +V<sub>CC</sub> = +V<sub>DD</sub> + 5V, f<sub>S</sub> = 44.1kHz, f<sub>sys</sub> = 384/256fs, and 16-bit data, unless otherwise noted.

### DIGITAL FILTER

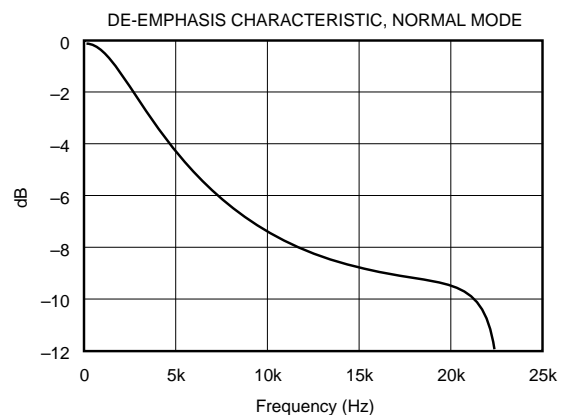
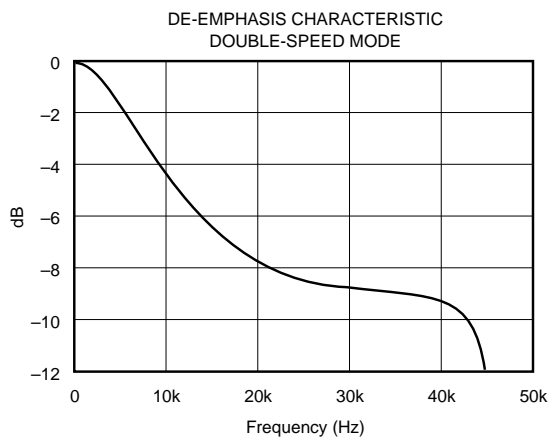
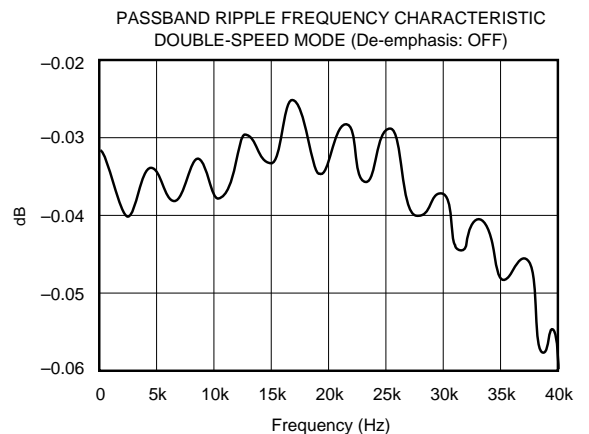
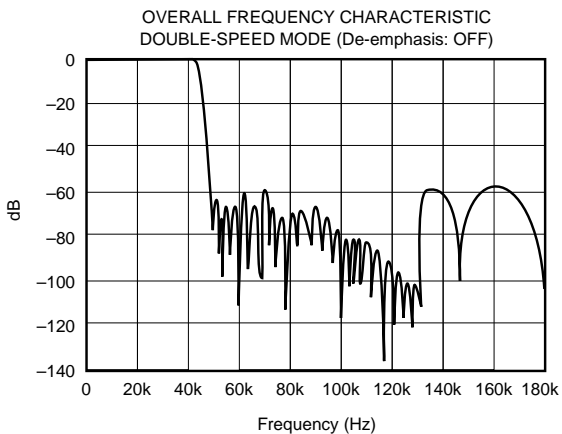
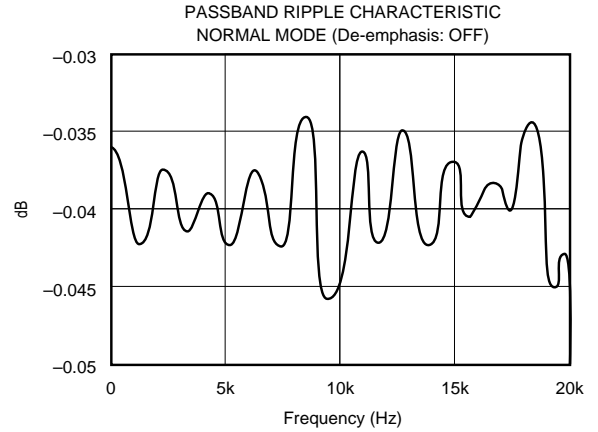
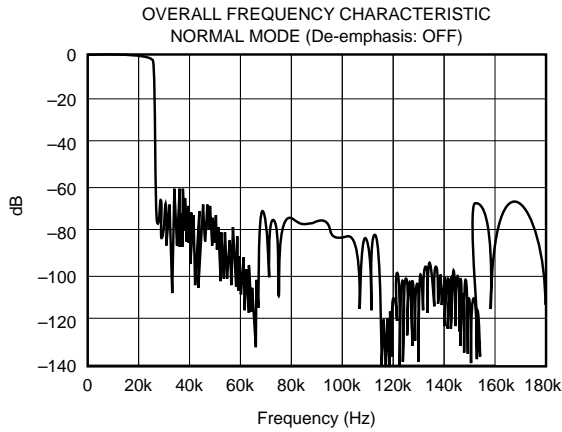



## TYPICAL PERFORMANCE CURVES (CONT)

At  $T_A = +25^\circ\text{C}$ ,  $V_S = \pm 5\text{V}$ ,  $R_L = 100\Omega$ ,  $C_L = 2\text{pF}$ , and  $R_{FB} = 402\Omega$ , unless otherwise noted. Based on 200 piece sample from 3 diffusion runs.

### DYNAMIC PERFORMANCE

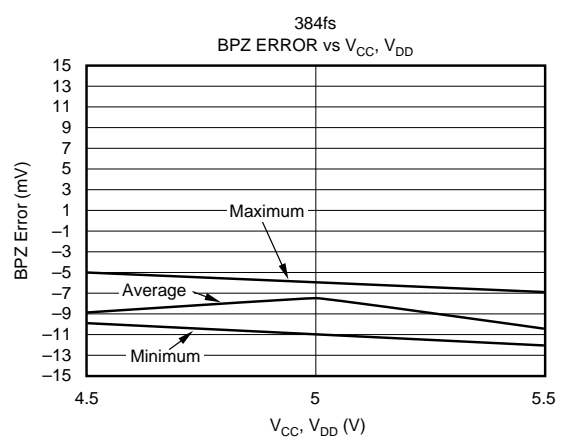
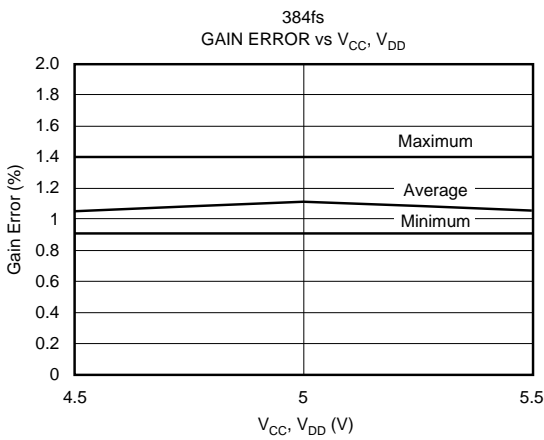
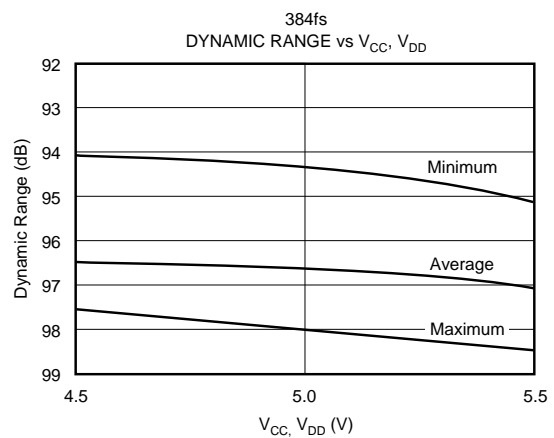
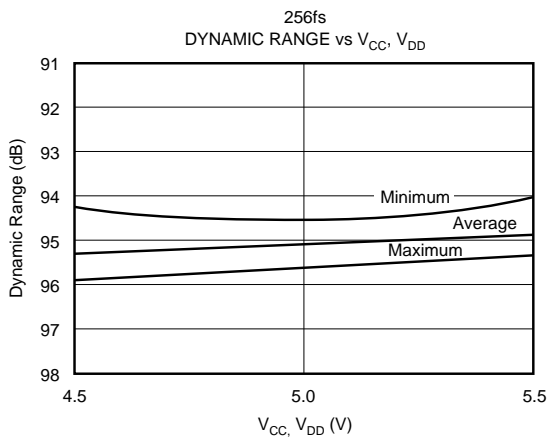
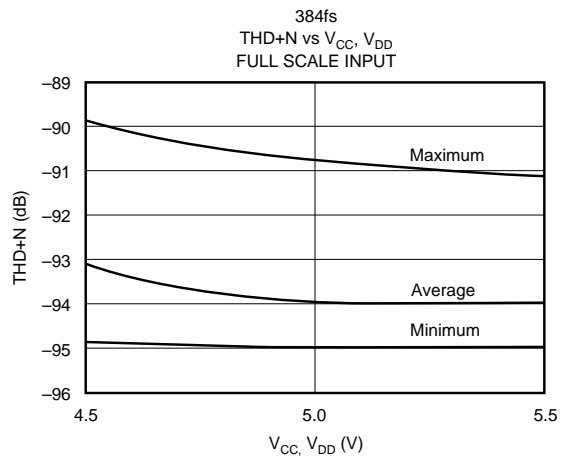
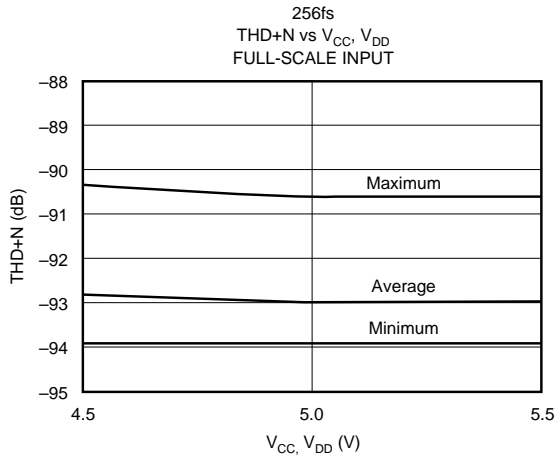

## TYPICAL PERFORMANCE CURVES (CONT)

At  $T_A = +25^\circ\text{C}$ ,  $V_S = \pm 5\text{V}$ ,  $R_L = 100\Omega$ ,  $C_L = 2\text{pF}$ , and  $R_{FB} = 402\Omega$ , unless otherwise noted. Based on 200 piece sample from 3 diffusion runs.

### DYNAMIC PERFORMANCE

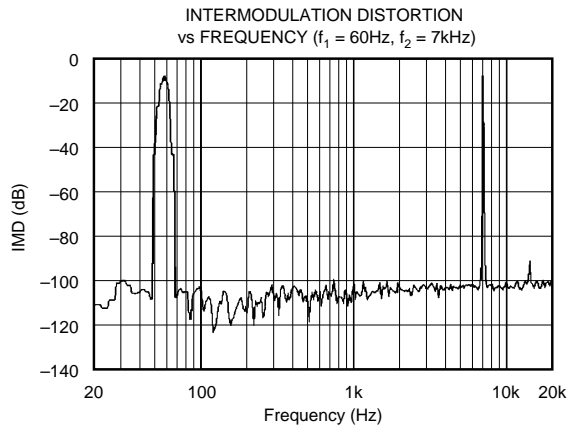
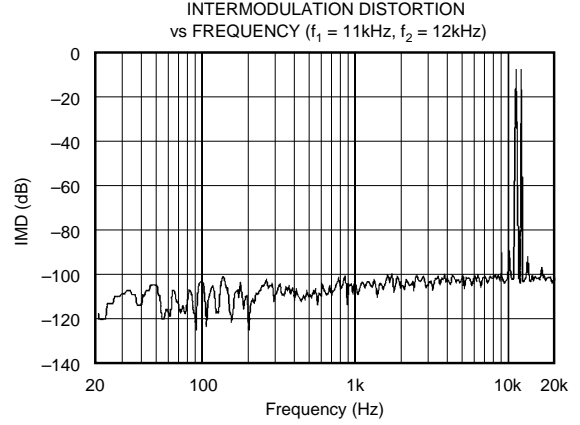
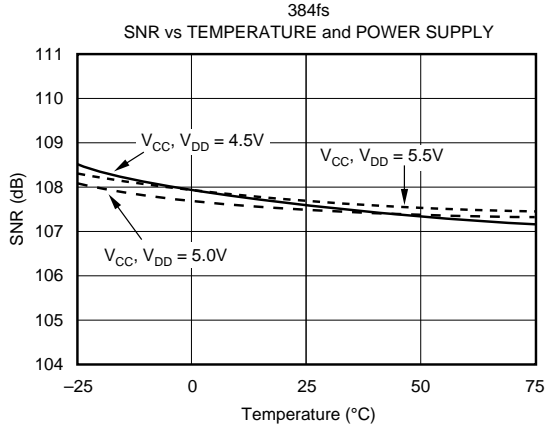

**CAUTION:** Minimum and maximum values on typical performance curves are not meant to imply a guarantee. Curves should be used for reference only. Refer to specification for guaranteed performances.

## FUNCTIONAL DESCRIPTION

PCM1710 has several built-in functions including digital attenuation, digital de-emphasis and soft mute. These functions are software controlled. PCM1710 can be operated in two different modes, **Serial** or **Parallel**. Serial Mode is a three-wire interface using pin 26 (MD), pin 27 (MC), and pin 28 (ML). Data on these pins are used to control de-emphasis mode, mute, double-speed dubbing, input resolution and input format. PCM1710 can also be operated in parallel mode, where static control signals are used on pin 26 (DM1), pin 27 (DM2), and pin 28 (DSD). Operation of both of these modes are covered in detail in the next sections.

**CAUTION:** Mode control signals operate on level triggered logic. The minimum timing conditions detailed in Figures 5 and 6 MUST be observed.

### MODE CONTROL: SERIAL/PARALLEL SELECTION

MODE = H	Serial Mode
MODE = L	Parallel Mode

TABLE III. Serial and Parallel Mode are Selectable by MODE Pin (Pin 24).

### MODE CONTROL: SELECTABLE FUNCTIONS

FUNCTION	SERIAL MODE (MODE = H)	PARALLEL MODE (MODE = L)
Input Data Format Selection	0	X(Normal Mode Fixed)
Input Data Bit Selection	0	X(16-bit Fixed)
Input LRCI Polarity Selection	0	X
De-emphasis Control	0	0
Mute	0	0
Attenuation	0	X
Double Speed Dubbing	0	0

NOTE: 0: Selectable, X: Not Selectable.

TABLE IV. Selectable Functions in Serial Mode and Parallel Mode.

Table IV indicates which functions are selectable within the user's chosen mode. All of the functions shown are selectable within the serial mode, but only de-emphasis control, mute and double-speed dubbing may be selected when using PCM1710 in the parallel mode.

### PARALLEL-MODE: DE-EMPHASIS CONTROL (PIN 24 [MODE] = L)

DM1 (Pin 26)	DM2 (Pin 27)	De-emphasis
L	L	OFF
H	L	32kHz
L	H	48kHz
H	H	44.1kHz

TABLE V. De-emphasis (Pins 26 and 27).

In the parallel mode, de-emphasis conditions are controlled by the logic levels on pin 26 (DM1) and pin 27 (DM2). For PCM1710, de-emphasis can operate at 32kHz, 44.1kHz, 48kHz, or disabled.

### PARALLEL-MODE: DOUBLE-SPEED DUBBING CONTROL (PIN 24 [MODE] = L)

DSD = H	Normal Mode
DSD = L	Double-Speed Dubbing Mode

NOTE: When the Double-Speed Dubbing Mode is selected, the System Clock must be 384fs (CKSL: Pin 23 = H).

TABLE VI. DSD (Pin 28).

In the parallel mode, double-speed dubbing can be enabled by holding pin 28 (DSD) at a logic "low".

**CAUTION:** Double-speed dubbing cannot operate if the system clock is set at 256fs.

### SERIAL MODE CONTROL

In order to use all of PCM1710's functionality, the **serial mode control** should be used. PCM1710 must be addressed three separate times to set all of the various registers and flags that control these functions.

Table VII together with Figure 6 details the control of the PCM1710 in the serial mode. Internal latches are used to hold this serial data until the PCM1710 is enabled to use the data. The serial mode is used by applying clocked data to the following pins:

NAME	PIN	FUNCTION
MC	27	Clock for Strobing in Data
ML	28	Latches Data into the Registers
MD	26	8-bit Data Word Defining Operation

	B0	B1	B2	BIT NO.	MODE FLAG	FUNCTION MODE SELECTION			MODE BY DEFAULT				
						MODE	BIT VALUE	SELECTED FUNCTION					
Mode 1	H	L	L	B3	DEEM2	Sampling Frequency for De-emphasis		DEEM2		OFF			
				B4	DEEM1			DEEM1	0		0	1	48kHz
								1	32kHz		44.1kHz		
				B5	IIR	De-emphasis	0	De-emphasis OFF			OFF		
							1	De-emphasis ON					
				B6	MUTE	Mute	0	Mute OFF			OFF		
							1	Mute ON					
B7	DSD	Double-Speed	0	Double-speed OFF		OFF							
			1	Double-speed ON									
Mode 2	H	L	H	B3		Not Assigned							
				B4	TST	Test Mode	0	Infinite Zero Detection OFF		ON			
							1	Infinite Zero Detection ON					
				B5	IW	Input Resolution	0	16-Bit		16-Bit			
							1	20-Bit					
				B6	LRPL	Polarity for LRCL	0	Lch:high/Rch:low		Lch:high Rch:low			
							1	Lch:low/Rch:high					
B7	IIS	Input Format	0	Normal		Normal							
			1	IIS									

TABLE VII. Serial-Mode Control Input Format (Pin 24 [MODE] = H)—Refer to Figure 6 for Timing Diagram.

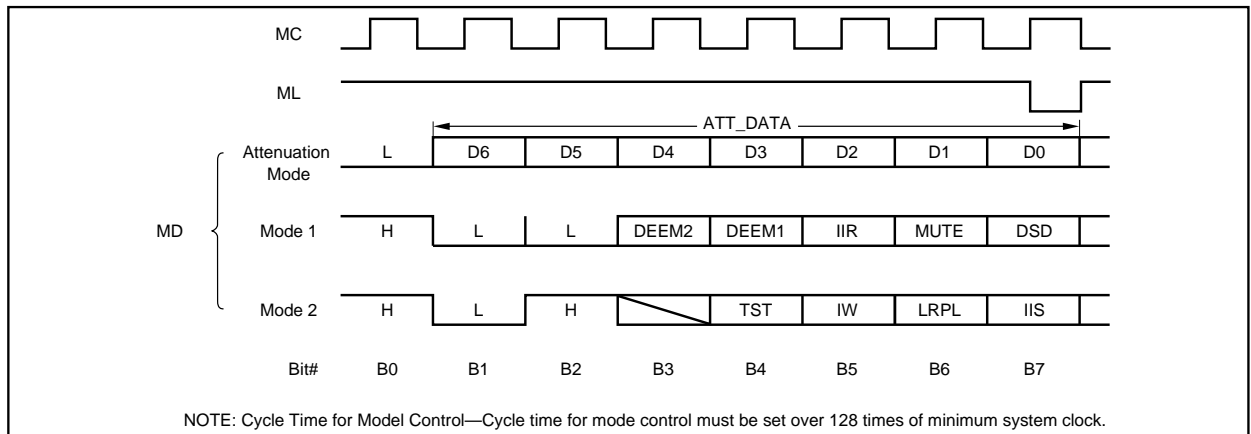

FIGURE 6. Mode Control Input Format, Serial Mode.

### DIGITAL ATTENUATION

One of the functions which can be implemented through use of the serial mode control is attenuation. This function allows the user to control the level of the output, independent of the of the input level set by the actual input data supplied to the DAC.

Referring to Figure 6, when the first data bit (B0) on MD (pin 26) is low, the attenuation function is enabled. The next seven bits (B1 - B6) define a binary value, ATT\_DATA, that indicates the desired level of attenuation. The attenuation level is given by:

$$\text{Level} = 20\log_{10} (1 - \text{ATT\_DATA}/127) \text{ dB}$$

When all 7 bits of the ATT\_DATA word are high (ATT\_DATA = 127), attenuation is infinite and the output of PCM1710 will be zero.

### MODE 1 CONTROLS

This mode can be enabled with the sequence of 1, 0, 0 as the first three bits on MD (pin 26). This mode allows for the following functions:

De-emphasis	On/Off
De-emphasis Frequency	32kHz, 44.1kHz, 48kHz
Soft Mute	On/Off
Double-Speed Dubbing	On/Off

### DIGITAL DE-EMPHASIS

PCM1710 allows three different sampling rates for digital de-emphasis. B3 and B4 are used for binary control of the de-emphasis frequency:

B3	B4	Frequency
0	0	OFF
0	1	48kHz
1	0	32kHz
1	1	44.1kHz

Once the reset has been established on pin 27 (MC), the de-emphasis frequency defaults to 44.1kHz. B5 is a master control for de-emphasis. A high level on B5 enables de-emphasis (frequency controlled by B3 and B4), and a low level on B5 disables de-emphasis.

### SOFT MUTE

Soft mute is enabled when B6 is high. The soft mute occurs gradually, unlike the forced infinite zero detection. When the mute data bit is high, complete muting will occur in  $127/f_s$  seconds. For  $f_s = 44.1\text{kHz}$ , complete mute will occur in 2.88ms.

### DOUBLE-SPEED DUBBING

Double-speed dubbing is used when the application allows for the CD to be copied at twice the normal playback rate. Double-speed dubbing is enabled when B7 is high. This mode can only operate when the system clock is set at 384fs. Double-speed dubbing can only occur when the sample rate is 44.1kHz. Since  $f_s$  is set at 44.1kHz, the system clock in double-speed mode is at 192fs.

## MODE 2 CONTROLS

Mode 2 is enabled when B0 is high, B1 is low, and B2 is high. This mode controls infinite zero detection, input resolution, LRCI polarity and input format.

### INFINITE ZERO DETECTION

B4 is used to enable or disable infinite zero detection. PCM1710 monitors both data input (DIN) and bit clock (BCKIN). When the data input is continuously zero or one for 65,536 cycles of the bit clock, infinite zero detection occurs, which forces the output of the PCM1710 to one-half of  $V_{CC}$  (typically 2.5V). Once this happens, only the output amplifier is connected. This is done to avoid having the noise shaped output spectrum of the DAC appear at the output of the PCM1710. This function is especially useful for CD applications when the player is between tracks. An inherent attribute of all delta-sigma architectures is the presence of quantization noise when the input is constant (all 1s or 0s). When the zero detect circuit disconnects the DAC from the output amplifier, a very low level “click” noise may be audible. The click noise occurs at approximately  $-76\text{dB}$ , and in many cases is inaudible.

### INPUT RESOLUTION

PCM1710 is capable of accepting either 16-bit or 20-bit input data. Specifications for PCM1710 are tested and guaranteed using 16-bit data. When 20 bits are used, dynamic performance is improved by approximately 2dB. Refer to “Typical Performance Curves” for a comparison of 16-bit and 20-bit data. A low on B5 places PCM1710 in 16-bit mode, and a high on B5 sets PCM1710 to 20-bit mode.

### SAMPLE RATE CLOCK POLARITY

B6 controls the polarity of the sample rate clock (LRCIN) polarity. When B6 is low, data will be accepted on the left channel when LRCIN is high, and on the right channel when LRCIN is low. When B6 is high, data will be accepted on the right channel when LRCIN is high, and on the left channel when LRCIN is low.

### INPUT FORMAT

Normal input mode for PCM1710 is MSB first, right justified. PCM1710 may also be operated with IIS (32 continuous clock cycles per word) input format. When B7 is low, the input format is “normal”. When B7 is high, the input format is “IIS”. However, PCM1710 can only accept IIS input format when it is in 16-bit mode. 20-bit data must be entered in normal mode.

### DEFAULT MODE

At initial power-on, default settings for PCM1710 are 44.1kHz  $f_s$ , de-emphasis off, mute off, double-speed off, infinite zero detect on, 16-bit input LRCIN left channel high, and normal input mode.

### SYSTEM CLOCK

SAMPLING FREQUENCY	SYSTEM CLOCK FREQUENCY	
32kHz	256fs	8.1920MHz
32kHz	384fs	12.2880MHz
44.1kHz	256fs	11.2896MHz
44.1kHz	384fs	16.9344MHz
48kHz	256fs	12.2880MHz
48kHz	384fs	18.4320MHz

TABLE VIII. Relationship of  $f_s$  and System Clock.

### NORMAL/DOUBLE-SPEED DUBBING

For most CD playback applications operating at 384fs, the system clock frequency must be 16.9344MHz, in both the normal mode and double-speed dubbing mode. Table VIII illustrates the relationship between  $f_s$  and output clock frequency in both modes.

PARAMETER	ML/DSD (PIN 28)	
	H (Normal)	L (Double Speed)
XTI Input Clock Frequency	384fs	192fs
XTI Frequency	16.9344MHz ( $f_s = 44.1\text{kHz}$ )	16.9344MHz ( $f_s = 88.2\text{kHz}$ )
CLKO Output Clock Frequency	384fs	192fs

TABLE IX. Relationship Between Normal/Double Speed and  $f_s$ .

**EXTERNAL SYSTEM CLOCK**

Figure 7 is a diagram showing the internal clock in conjunction with an external crystal oscillator.

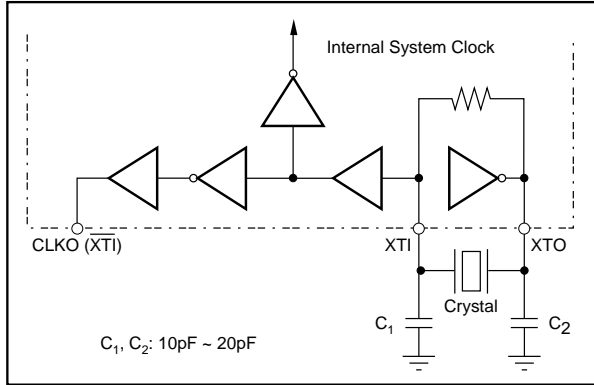

FIGURE 7. External Crystal Oscillator.

Figure 8 is a diagram showing the internal clock with an external clock source, instead of an oscillator. An external system clock (input to XTI) must meet the following conditions:

<b>HIGH LEVEL</b>	$V_{IH} > 0.64V_{DD}$	$T_H > 10ns$
<b>LOW LEVEL</b>	$V_{IL} > 0.28V_{DD}$	$T_L > 10ns$

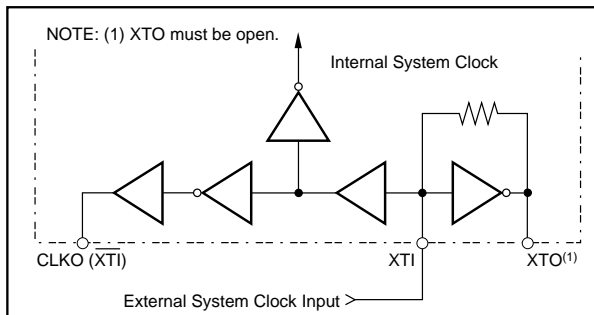

FIGURE 8. External System Clock.

**POWER SUPPLY CONNECTIONS**

PCM1710 has two power supply connections: digital ( $V_{DD}$ ) and analog ( $V_{CC}$ ). Each connection also has a separate ground. If the power supplies turn on at different times, there is a possibility of a latch-up condition. To avoid this condition, it is recommended to have a common connection between the digital and analog power supplies. If separate supplies are used without a common connection, the delta between the two supplies during ramp-up time must be less than 0.6V.

An application circuit to avoid a latch-up condition is shown in Figure 9.

**BYPASSING POWER SUPPLIES**

The power supplies should be bypassed as close as possible to the unit. Refer to Figure 19 for optimal values of bypass capacitors. For applications which require very high perfor-

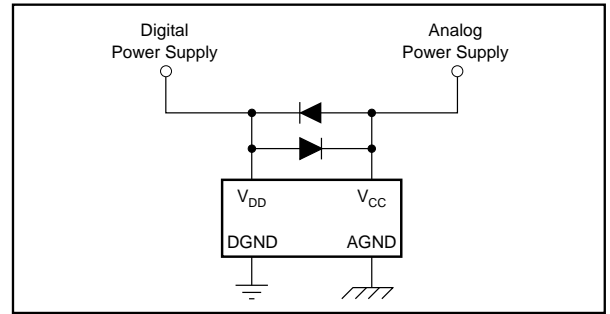

FIGURE 9. Latch-up Prevention Circuit.

mance at low levels (such as keyboards, synthesizers, etc.) it may be beneficial to provide additional bypassing on pin 15 ( $V_{CC1}$ ) with a low ESR 100µF capacitor. This will eliminate stray tones which may be above the noise floor.

**THEORY OF OPERATION**

PCM1710 is an oversampling delta-sigma D/A converter, consisting of an input interface/attenuator, a 4th-order multi-level delta-sigma modulator, a low pass filter and an output amplifier (see Figure 10).



**MODULATOR**

The delta-sigma section of the PCM1710 is based on a 5-level amplitude quantizer and a 4th-order filter. This converts oversampled 16-or 20-bit input data to 5-level delta-sigma format. A block diagram of the 5-level modulator is shown in Figure 11.

This 5-level delta-sigma modulator has the advantage of improved stability and jitter sensitivity over the typical one bit (2-level) delta-sigma modulator.

The combined oversampling rate of the delta-sigma modulator and the internal 8X oversampling digital filter is 48fs at a system clock of 384fs and 32fs at a system clock of 256fs.

A block diagram of the 4th-order filter section  $H_f(z)$  in the delta-sigma modulator is shown in Figure 12.

In general, high order one-bit delta-sigma modulators have disadvantages due to loop instability (multiple integration stages). The five level delta-sigma modulator of the PCM1710 uses phase compensation techniques to obtain stable operation. In Figure 12, the coefficients B1 to B4 give the basic form of the filter, and A2 to A4 are used for phase compensation of the feedback loop.

The theoretical quantization noise performance of five level delta-sigma modulator is shown in Figure 13 and 14. In the audio band, the quantization noise floor level of the PCM1710 is less than 130dB (at a system clock of 384fs).

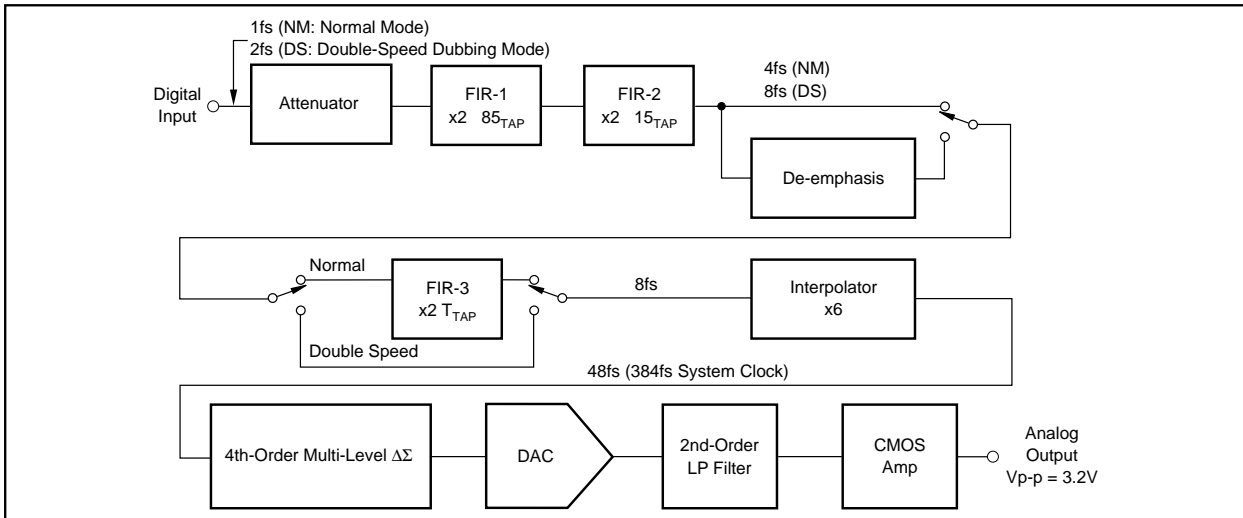

FIGURE 10. PCM1710 Block Diagram.

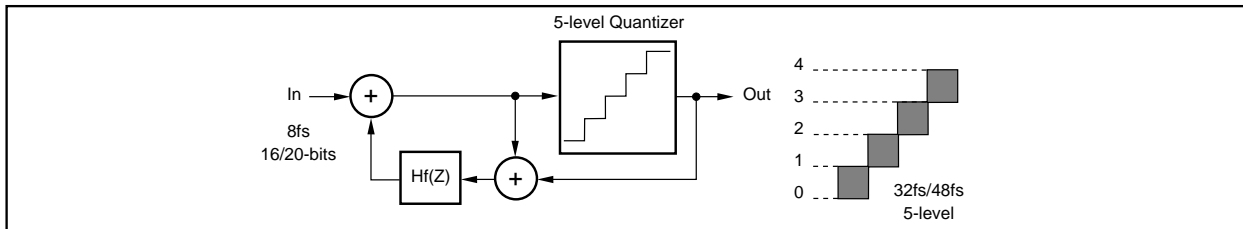

FIGURE 11. Block Diagram of Multi-level  $\Delta\Sigma$  Modulator.

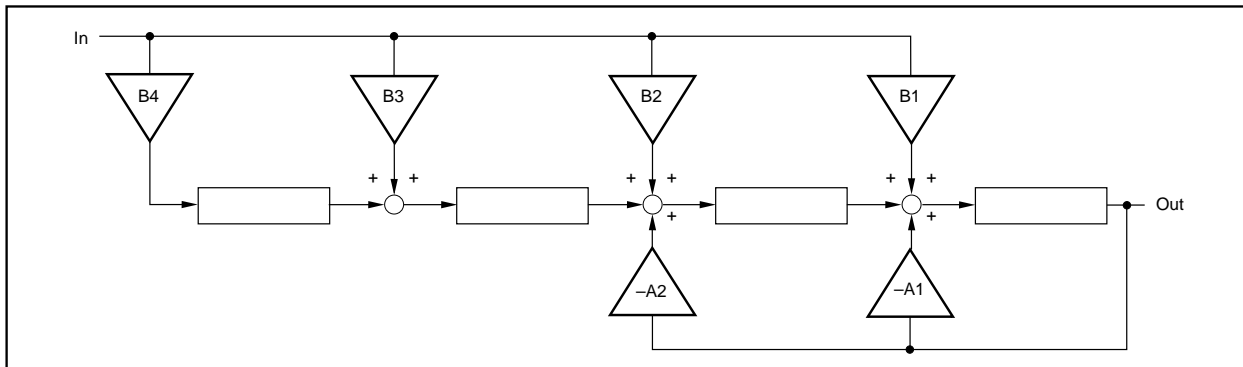

FIGURE 12. Block Diagram of 4th-order Filter Section ( $H_f(z)$ ).

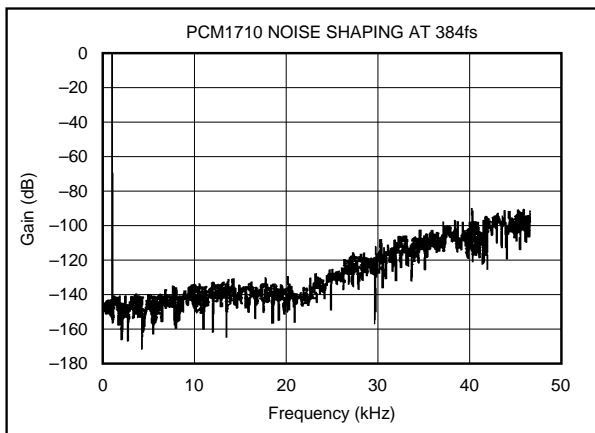

FIGURE 13. Theoretical Modulator Performance at 384fs.

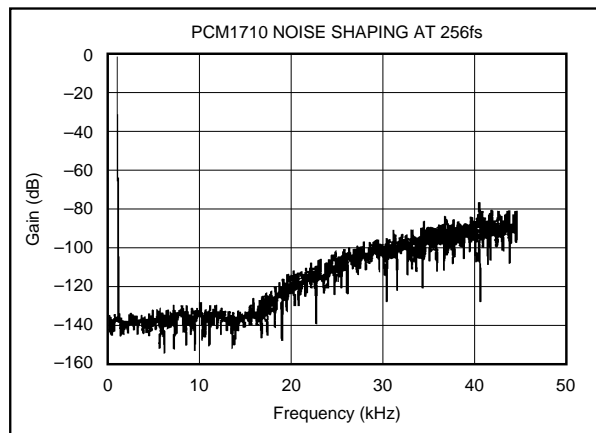

FIGURE 14. Theoretical Modulator Performance at 256fs.

## APPLICATION CONSIDERATIONS

### 16-BIT vs 20-BIT OPERATION

In the serial mode, PCM1710 can be configured to accept either 16-bit or 20-bit data. The specifications listed in this data sheet are the 16-bit data. Some improvements in dynamic performance can be realized by using 20-bit data.

Internally, the PCM1710's digital filter uses only 20-bit data. If the input data is 16-bit, the filter adds four zeros to complete the 20-bit input word. Typical performance differences between 16-bit and 20-bit data are shown in Tables X and XI.

DATA	256fs	384fs
16-bit	-91dB	-93dB
20-bit	-94dB	-96dB

TABLE X. THD+N Performance at Full Scale.

DATA	256fs	384fs
16-bit	94dB	96dB
20-bit	96dB	98dB

TABLE XI. Dynamic Range.

### DELAY TIME

There is a finite delay time in delta-sigma converters. In A/D converters, this is commonly referred to as latency. For a delta-sigma D/A converter, delay time is determined by the order number of the FIR filter stage, and the chosen sampling rate. The following equation expresses the delay time of PCM1710:

$$T_D = 22.625 \times 1/f_s$$

For  $f_s = 44.1\text{kHz}$ ,  $T_D = 22.625/44.1\text{kHz} = 513.04\mu\text{s}$

Applications using data from a disc or tape source, such as CD audio, CD-Interactive, Video CD, DAT, Minidisc, etc., generally are not affected by delay time. For some professional applications such as broadcast audio for studios, it is important for total delay time to be less than 2ms.

### INTERNAL RESET

If the sample rate clock (LRCIN) is stopped during operation, the infinite zero detect circuit will cause the output to go to  $V_{CC}/2$  after 65,536 cycles of the bit clock (BCKIN). Once a new system clock has been applied, there will be a delay until output data is correlated to the input. This is due to the digital delay of the filter.

When power is first applied to PCM1710, an automatic reset function occurs after 64 cycles of LRCIN.

### CHANGING SAMPLING RATE

For normal operation, LRCIN and XTI should be synchronized at either 256fs or 384fs. When the sampling rate is

changed during operation, output data is invalid during the delay period ( $T_D$ ) and for two subsequent cycles of LRCIN. After two cycles of LRCIN, the output is a valid representation of the input data.

### OUTPUT FILTERING

For testing purposes all dynamic tests are done on the PCM1710 using a 20kHz low pass filter. This filter limits the measured bandwidth for THD+N, etc. to 20kHz. Failure to use such a filter will result in higher THD+N and lower SNR and Dynamic Range readings than are found in the specifications. The low pass filter removes out of band noise. Although it is not audible, it may affect dynamic specification numbers.

The performance of the internal low pass filter from DC to 24kHz is shown in Figure 15. The higher frequency rolloff of the filter is shown in Figure 16. If the user's application has the PCM1710 driving a wideband amplifier, it is recommended to use an external low pass filter. A simple 3rd-order filter is shown in Figure 17. For some applications, a passive RC filter or 2nd-order filter may be adequate.

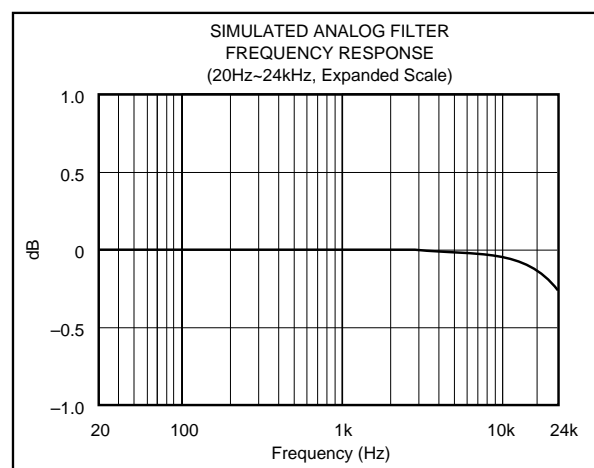

FIGURE 15. Low Pass Filter Frequency Response.

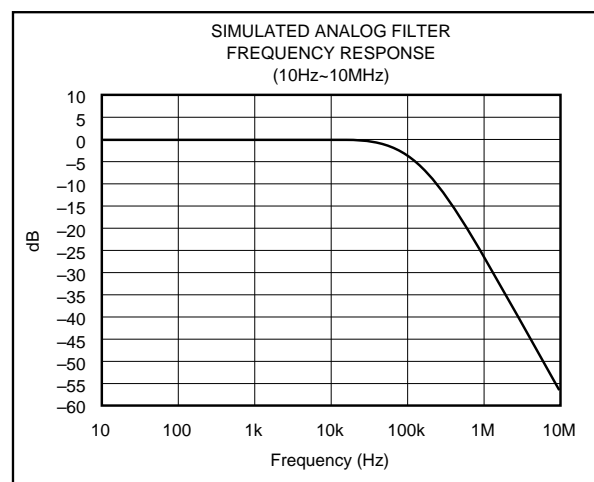

FIGURE 16. Low Pass Filter Frequency Response.



**TEST CONDITIONS**

Figure 18 illustrates the actual test conditions applied to PCM1710 in production. The 11th-order filter is necessary in the production environment for the removal of noise, resulting from the relatively long physical distance between the unit and the test analyzer. In most actual applications, the third-order filter shown in Figure 17 is adequate. Under normal conditions, THD+N typical performance is -70dB with a 30kHz low pass filter (shown here on the THD meter), improving to -92dB when the external 20kHz second-order filter is used.

**EVALUATION FIXTURES**

Two different evaluation fixtures are available for PCM1710.

**DEM-PCM1710**

This evaluation fixture is primarily intended for quick evaluation of the PCM1710's performance. DEM-PCM1710 can accept either an external clock or a user-installed crystal

oscillator. All of the functions can be controlled by on-board switches. DEM-PCM1710 does not contain a receiver chip or an external low pass filter. DEM-PCM1710 requires a single +5V power supply.

**DEM-DAI1710**

This fixture is more complete than DEM-PCM1710; it includes a Digital Audio Interface (DAI) receiver chip for easy use and to provide a low-jitter 256fs system clock to the PCM1710. Also included are dual second-order low pass filters using Burr-Brown's OPA2604 dual FET-input op amp. The output of the DEM-DAI1710 is 2Vrms, using standard BNC-type connectors.

All of the functions of PCM1710 can be evaluated by using the DEM-DAI1710 jumper selections. DEM-DAI1710 requires +5V and ±5V to ±15V power supplies. The schematic diagram for DEM-DAI1710 is shown in Figure 19. For more detailed information on the evaluation fixtures, contact your local Burr-Brown representative.

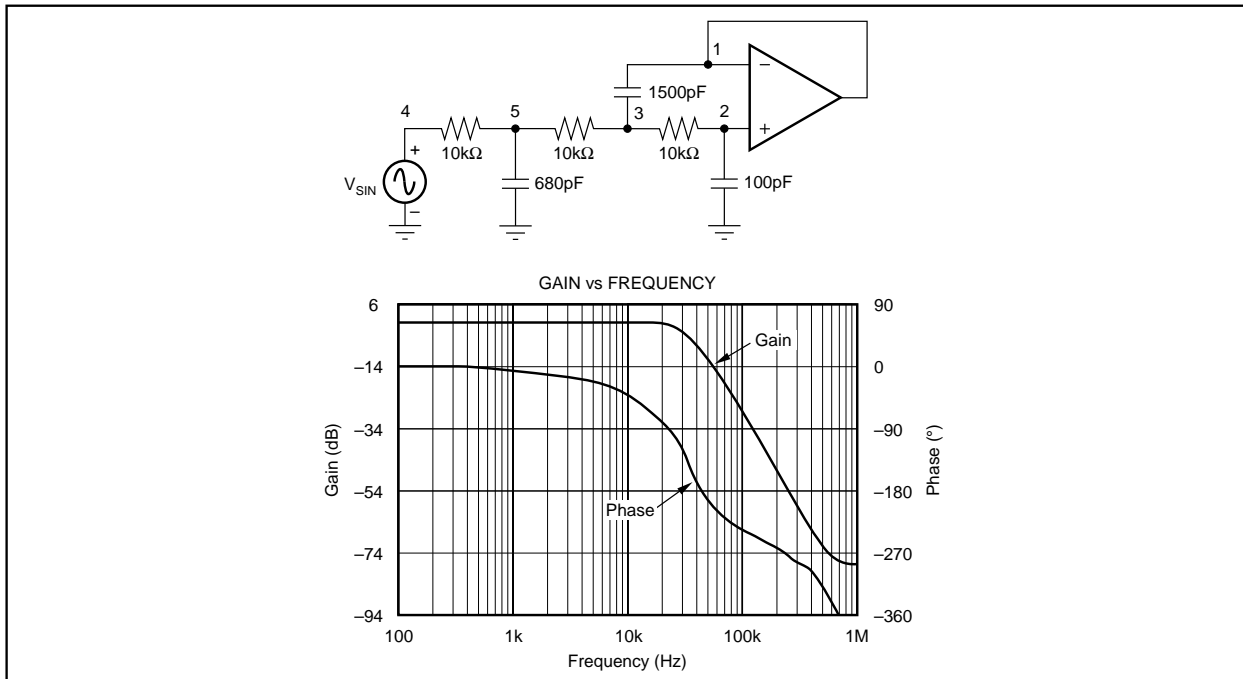

FIGURE 17. 3rd-Order LPF.

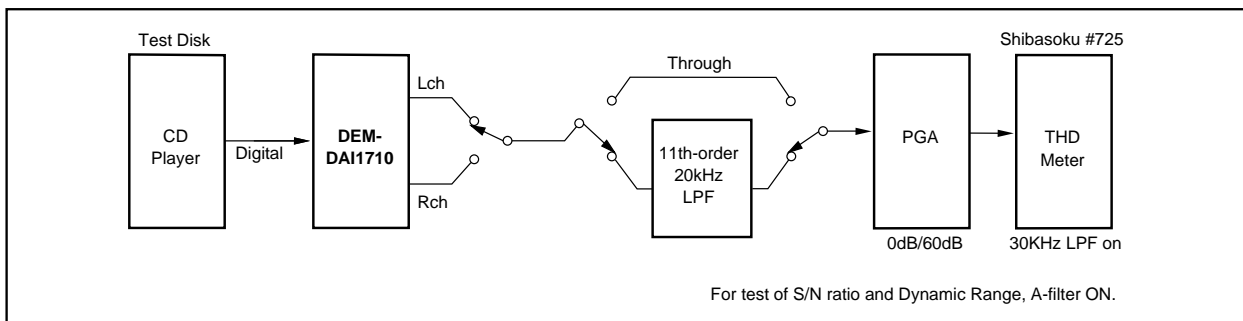

FIGURE 18. Test Block Diagram.

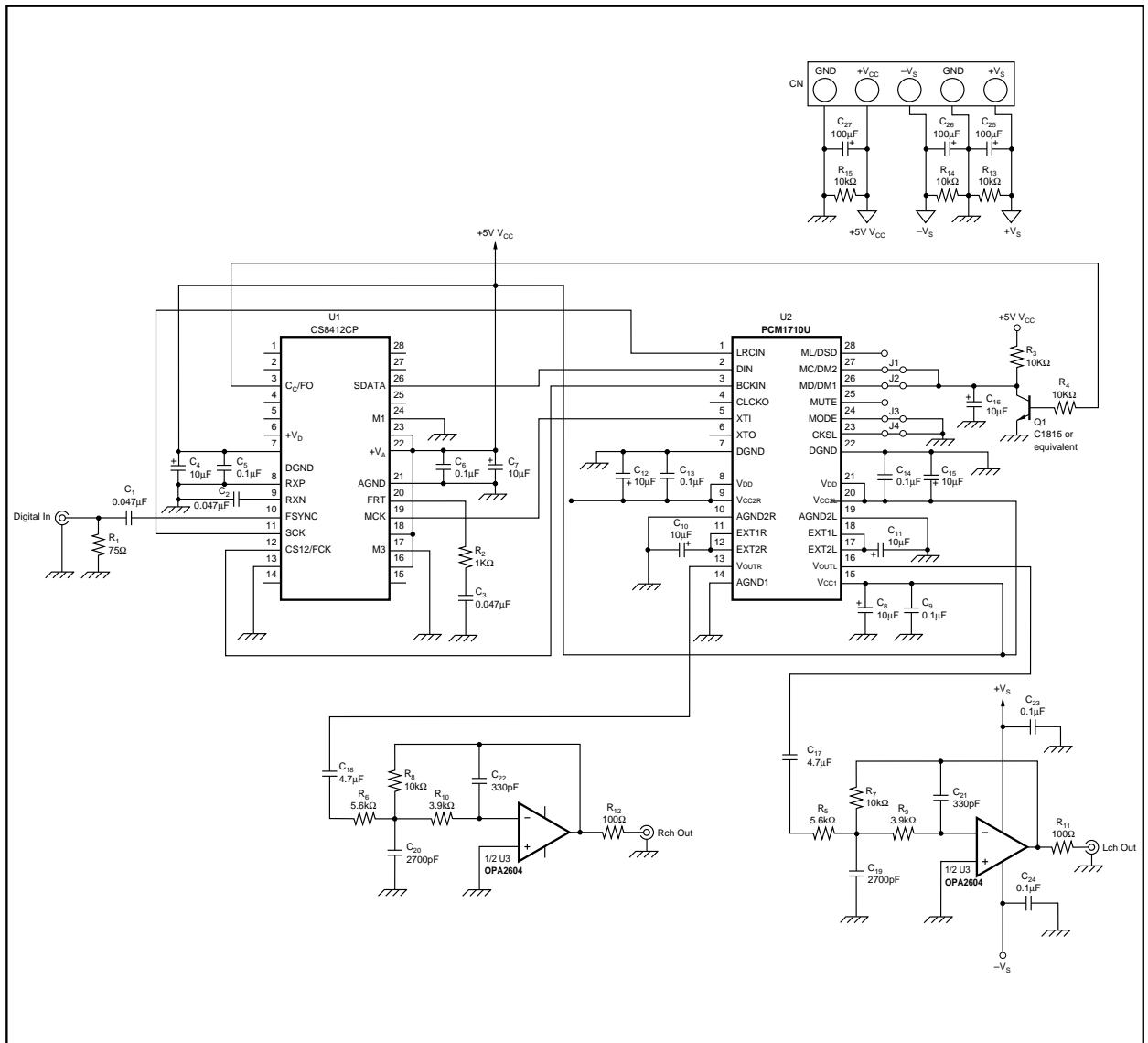

FIGURE 19. DEM-DAI1710 Schematic Circuit Diagram.



PACKAGING INFORMATION

Orderable Device	Status (1)	Package Type	Package Drawing	Pins	Package Qty	Eco Plan (2)	Lead/Ball Finish (6)	MSL Peak Temp (3)	Op Temp (°C)	Device Marking (4/5)	Samples
PCM1710U	OBSOLETE	SOIC	DW	28		TBD	Call TI	Call TI		PCM1710U	

(1) The marketing status values are defined as follows:

**ACTIVE:** Product device recommended for new designs.

**LIFEBUY:** TI has announced that the device will be discontinued, and a lifetime-buy period is in effect.

**NRND:** Not recommended for new designs. Device is in production to support existing customers, but TI does not recommend using this part in a new design.

**PREVIEW:** Device has been announced but is not in production. Samples may or may not be available.

**OBSOLETE:** TI has discontinued the production of the device.

(2) Eco Plan - The planned eco-friendly classification: Pb-Free (RoHS), Pb-Free (RoHS Exempt), or Green (RoHS & no Sb/Br) - please check <http://www.ti.com/productcontent> for the latest availability information and additional product content details.

**TBD:** The Pb-Free/Green conversion plan has not been defined.

**Pb-Free (RoHS):** TI's terms "Lead-Free" or "Pb-Free" mean semiconductor products that are compatible with the current RoHS requirements for all 6 substances, including the requirement that lead not exceed 0.1% by weight in homogeneous materials. Where designed to be soldered at high temperatures, TI Pb-Free products are suitable for use in specified lead-free processes.

**Pb-Free (RoHS Exempt):** This component has a RoHS exemption for either 1) lead-based flip-chip solder bumps used between the die and package, or 2) lead-based die adhesive used between the die and leadframe. The component is otherwise considered Pb-Free (RoHS compatible) as defined above.

**Green (RoHS & no Sb/Br):** TI defines "Green" to mean Pb-Free (RoHS compatible), and free of Bromine (Br) and Antimony (Sb) based flame retardants (Br or Sb do not exceed 0.1% by weight in homogeneous material)

(3) MSL, Peak Temp. - The Moisture Sensitivity Level rating according to the JEDEC industry standard classifications, and peak solder temperature.

(4) There may be additional marking, which relates to the logo, the lot trace code information, or the environmental category on the device.

(5) Multiple Device Markings will be inside parentheses. Only one Device Marking contained in parentheses and separated by a "-" will appear on a device. If a line is indented then it is a continuation of the previous line and the two combined represent the entire Device Marking for that device.

(6) Lead/Ball Finish - Orderable Devices may have multiple material finish options. Finish options are separated by a vertical ruled line. Lead/Ball Finish values may wrap to two lines if the finish value exceeds the maximum column width.

**Important Information and Disclaimer:** The information provided on this page represents TI's knowledge and belief as of the date that it is provided. TI bases its knowledge and belief on information provided by third parties, and makes no representation or warranty as to the accuracy of such information. Efforts are underway to better integrate information from third parties. TI has taken and continues to take reasonable steps to provide representative and accurate information but may not have conducted destructive testing or chemical analysis on incoming materials and chemicals. TI and TI suppliers consider certain information to be proprietary, and thus CAS numbers and other limited information may not be available for release.

In no event shall TI's liability arising out of such information exceed the total purchase price of the TI part(s) at issue in this document sold by TI to Customer on an annual basis.

**MECHANICAL DATA**

DW (R-PDSO-G28)

PLASTIC SMALL OUTLINE

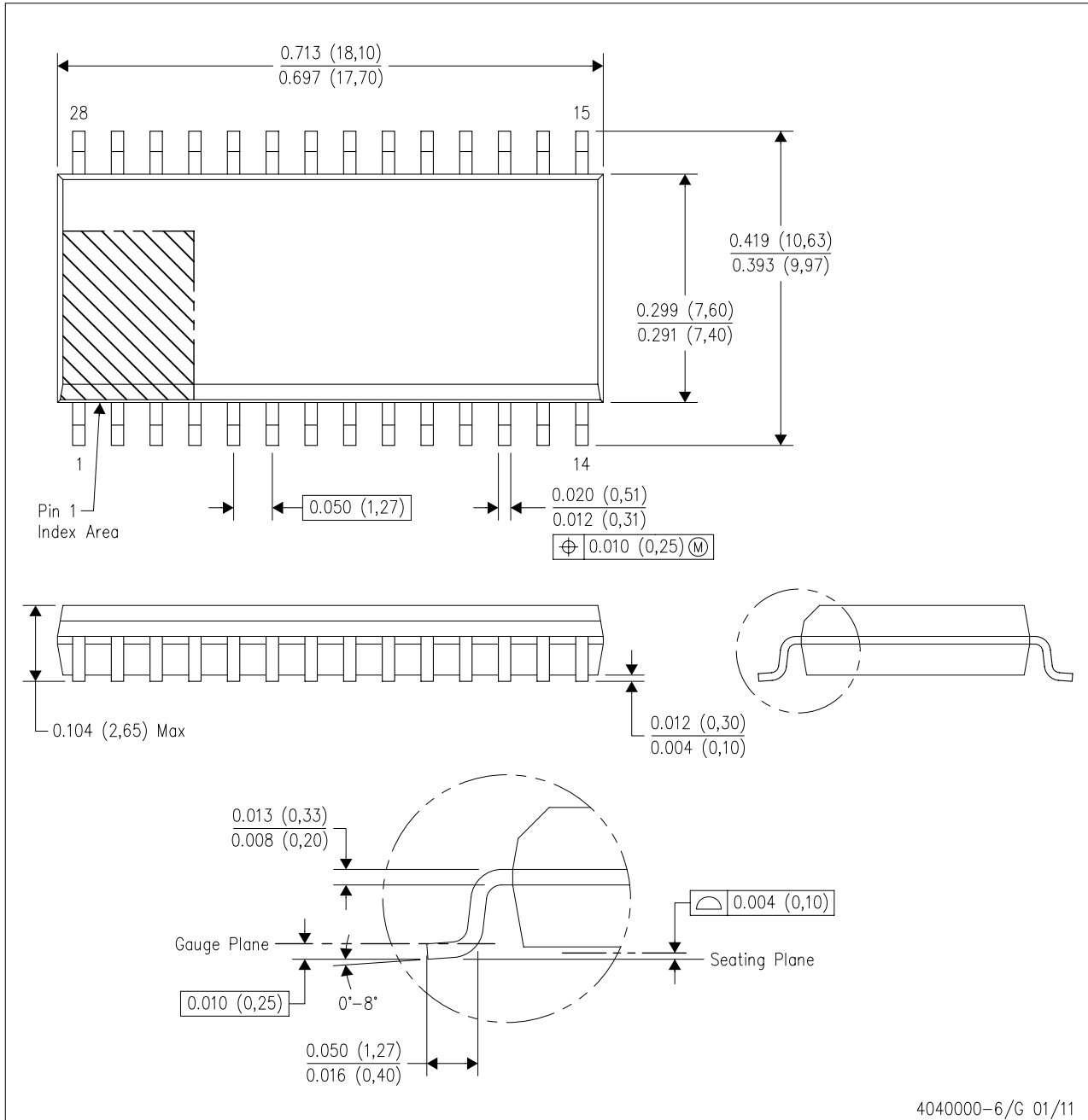

4040000-6/G 01/11

- NOTES:
- All linear dimensions are in inches (millimeters). Dimensioning and tolerancing per ASME Y14.5M-1994.
  - This drawing is subject to change without notice.
  - Body dimensions do not include mold flash or protrusion not to exceed 0.006 (0,15).
  - Falls within JEDEC MS-013 variation AE.

## IMPORTANT NOTICE

Texas Instruments Incorporated and its subsidiaries (TI) reserve the right to make corrections, enhancements, improvements and other changes to its semiconductor products and services per JESD46, latest issue, and to discontinue any product or service per JESD48, latest issue. Buyers should obtain the latest relevant information before placing orders and should verify that such information is current and complete. All semiconductor products (also referred to herein as “components”) are sold subject to TI’s terms and conditions of sale supplied at the time of order acknowledgment.

TI warrants performance of its components to the specifications applicable at the time of sale, in accordance with the warranty in TI’s terms and conditions of sale of semiconductor products. Testing and other quality control techniques are used to the extent TI deems necessary to support this warranty. Except where mandated by applicable law, testing of all parameters of each component is not necessarily performed.

TI assumes no liability for applications assistance or the design of Buyers’ products. Buyers are responsible for their products and applications using TI components. To minimize the risks associated with Buyers’ products and applications, Buyers should provide adequate design and operating safeguards.

TI does not warrant or represent that any license, either express or implied, is granted under any patent right, copyright, mask work right, or other intellectual property right relating to any combination, machine, or process in which TI components or services are used. Information published by TI regarding third-party products or services does not constitute a license to use such products or services or a warranty or endorsement thereof. Use of such information may require a license from a third party under the patents or other intellectual property of the third party, or a license from TI under the patents or other intellectual property of TI.

Reproduction of significant portions of TI information in TI data books or data sheets is permissible only if reproduction is without alteration and is accompanied by all associated warranties, conditions, limitations, and notices. TI is not responsible or liable for such altered documentation. Information of third parties may be subject to additional restrictions.

Resale of TI components or services with statements different from or beyond the parameters stated by TI for that component or service voids all express and any implied warranties for the associated TI component or service and is an unfair and deceptive business practice. TI is not responsible or liable for any such statements.

Buyer acknowledges and agrees that it is solely responsible for compliance with all legal, regulatory and safety-related requirements concerning its products, and any use of TI components in its applications, notwithstanding any applications-related information or support that may be provided by TI. Buyer represents and agrees that it has all the necessary expertise to create and implement safeguards which anticipate dangerous consequences of failures, monitor failures and their consequences, lessen the likelihood of failures that might cause harm and take appropriate remedial actions. Buyer will fully indemnify TI and its representatives against any damages arising out of the use of any TI components in safety-critical applications.

In some cases, TI components may be promoted specifically to facilitate safety-related applications. With such components, TI’s goal is to help enable customers to design and create their own end-product solutions that meet applicable functional safety standards and requirements. Nonetheless, such components are subject to these terms.

No TI components are authorized for use in FDA Class III (or similar life-critical medical equipment) unless authorized officers of the parties have executed a special agreement specifically governing such use.

Only those TI components which TI has specifically designated as military grade or “enhanced plastic” are designed and intended for use in military/aerospace applications or environments. Buyer acknowledges and agrees that any military or aerospace use of TI components which have **not** been so designated is solely at the Buyer’s risk, and that Buyer is solely responsible for compliance with all legal and regulatory requirements in connection with such use.

TI has specifically designated certain components as meeting ISO/TS16949 requirements, mainly for automotive use. In any case of use of non-designated products, TI will not be responsible for any failure to meet ISO/TS16949.

### Products

Audio	<a href="http://www.ti.com/audio">www.ti.com/audio</a>
Amplifiers	<a href="http://amplifier.ti.com">amplifier.ti.com</a>
Data Converters	<a href="http://dataconverter.ti.com">dataconverter.ti.com</a>
DLP® Products	<a href="http://www.dlp.com">www.dlp.com</a>
DSP	<a href="http://dsp.ti.com">dsp.ti.com</a>
Clocks and Timers	<a href="http://www.ti.com/clocks">www.ti.com/clocks</a>
Interface	<a href="http://interface.ti.com">interface.ti.com</a>
Logic	<a href="http://logic.ti.com">logic.ti.com</a>
Power Mgmt	<a href="http://power.ti.com">power.ti.com</a>
Microcontrollers	<a href="http://microcontroller.ti.com">microcontroller.ti.com</a>
RFID	<a href="http://www.ti-rfid.com">www.ti-rfid.com</a>
OMAP Applications Processors	<a href="http://www.ti.com/omap">www.ti.com/omap</a>
Wireless Connectivity	<a href="http://www.ti.com/wirelessconnectivity">www.ti.com/wirelessconnectivity</a>

### Applications

Automotive and Transportation	<a href="http://www.ti.com/automotive">www.ti.com/automotive</a>
Communications and Telecom	<a href="http://www.ti.com/communications">www.ti.com/communications</a>
Computers and Peripherals	<a href="http://www.ti.com/computers">www.ti.com/computers</a>
Consumer Electronics	<a href="http://www.ti.com/consumer-apps">www.ti.com/consumer-apps</a>
Energy and Lighting	<a href="http://www.ti.com/energy">www.ti.com/energy</a>
Industrial	<a href="http://www.ti.com/industrial">www.ti.com/industrial</a>
Medical	<a href="http://www.ti.com/medical">www.ti.com/medical</a>
Security	<a href="http://www.ti.com/security">www.ti.com/security</a>
Space, Avionics and Defense	<a href="http://www.ti.com/space-avionics-defense">www.ti.com/space-avionics-defense</a>
Video and Imaging	<a href="http://www.ti.com/video">www.ti.com/video</a>

### TI E2E Community

[e2e.ti.com](http://e2e.ti.com)