

## Excellent Integrated System Limited

Stocking Distributor

Click to view price, real time Inventory, Delivery & Lifecycle Information:

[Molex Connector Corporation](#)  
[0190690209](#)

For any questions, you can email us directly:

[sales@integrated-circuit.com](mailto:sales@integrated-circuit.com)

10	9	8	7	6	5	4	3	2	1
MATERIAL NO. LOOSE PIECE	ENG. NO.	MATERIAL NO. TAPE MOUNTED	ENG. NO.	STUD SIZE	"S" ±.005/0.13	STOCK THICKNESS	FINISH		
190690200	C-128-04	190690147	C-128-04T	4	.119/(3.02)	.040/(1.02)	SEE NOTE 2		
190690202	C-128-06	190690148	C-128-06T	6	.146/(3.71)				
190690205	C-128-08	190690208	C-128-08T	8	.173/(4.39)				
190690209	C-128-10	190690212	C-128-10T	10	.198/(5.03)				
190690215	C-128-209	---	---	209	.209/(5.18)				
192030159	C-U-128-06	192030111	C-U-128-06T	6	.146/(3.71)	.038/(0.97)	SEE NOTE 3		
192030160	C-U-128-08	192030112	C-U-128-08T	8	.173/(4.39)				
192030113	C-U-128-10	192030114	C-U-128-10T	10	.198/(5.03)				
190690682	C-128-10-AU	---	---	10	.198/(5.03)	.040/(1.02)	SEE NOTE 3		

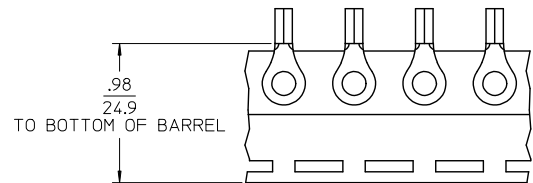
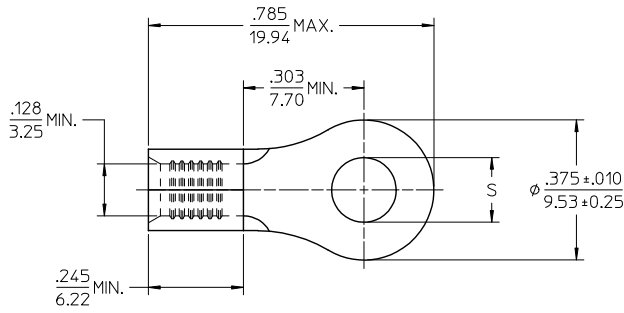

SALES DRAWING

NOTES:

1. MATERIAL: COPPER.
2. FINISH: TIN PLATING, 100(2.5)µin(µm) MIN
3. FINISH: GOLD, 50(1.25)µin(µm) MIN. OVER NICKEL, 50(1.25)µin(µm) MIN. PLATING.
4. WIRE SIZE: 12-10 AWG, 4.0-6.0 MM<sup>2</sup>
5. PARTS ARE ROHS COMPLIANT.

<b>RELEASED</b> EC NO: IPG2015-0823 DRAWN BY: JASO1 2014/10/30 CHKD: JMACNEIL 2014/10/30 APPR: JMACNEIL 2014/11/19	QUALITY SYMBOLS ▽=0 ▽=0	GENERAL TOLERANCES (UNLESS SPECIFIED)		DIMENSION STYLE IN/MM		SCALE ---	DESIGN UNITS INCH	THIRD ANGLE PROJECTION
		4 PLACES ±--- ±---	3 PLACES ±--- ±---	DRAWN BY BDEROSS DATE 2000/6/13	TITLE RING TONGUE TERMINAL KRIMP TITE, 128 SERIES 12-10 AWG			
		2 PLACES ±--- ±---	1 PLACE ±--- ±---	CHECKED BY JMACNEIL DATE 2014/10/30	APPROVED BY JMACNEIL DATE 2014/11/19			
		ANGULAR ±---°		MATERIAL NO. SEE CHART		DOCUMENT NO. SD-19069-020		SHEET NO. 1 OF 1
DRAFT WHERE APPLICABLE MUST REMAIN WITHIN DIMENSIONS		SIZE B		THIS DRAWING CONTAINS INFORMATION THAT IS PROPRIETARY TO MOLEX INCORPORATED AND SHOULD NOT BE USED WITHOUT WRITTEN PERMISSION				