

Excellent Integrated System Limited

Stocking Distributor

Click to view price, real time Inventory, Delivery & Lifecycle Information:

[Molex Connector Corporation](#)
[0011201259](#)

For any questions, you can email us directly:

sales@integrated-circuit.com



AM63181T
W.E. PHONE PLUG TERMINATOR

The AM-63181T series terminator die was designed for higher production needs where chain loaded plugs are used. These dies are used in the TM-40 terminating machine. (11-05-0018) with an adaptor kit. (11-21-9964) The adaptor kit consists of a modified die guard and terminal guide. Only one kit is required per TM-40 press. The terminator dies are available for 87031 4 & 6 pos. plugs and 90075 8 pos. plugs.

TERMINATOR SET-UP AND ADJUSTMENT:

To set up the press, do the following: (Refer to TM-40 press manual.)

1. Remove power from the press. Then remove the die guard and terminal guide from the press. (If there is a terminator die in the press, remove it.)
2. Then install the modified terminal guide to the press.
3. Install the striker assembly to the underside of the ram. (see 69017-0010 item #6)
4. Install the connector guide punch (where appropriate)
5. Load the termination and strain relief punches into the ram with the termination punch to the rear. Make sure that the release pin is engaged.
6. Lift the feed finger and load the terminator base assembly on to the bolster plate and lock in place.
7. Loosen the plug support mounting screws and manually lower the ram on the press to align the supports with the punches. Then tighten the screws.
8. Load a plug chain thru the terminator and adjust the feed finger to align with the feed slots in the chain. Then by means of hand cycling, adjust the feed to insure that the plug is centered on the plug supports.
9. Manually operate the ram and adjust the depth of termination so the terminals in the plug just touch the bottom of the pocket. This is done with the conductor punch adjustment on the press.
10. Adjust the latching punch so the primary strain relief is fully latched into the housing. This is done with the insulation punch adjustment on the press.
11. Install the modified die guard supplied with the adaptor kit and turn on the power.

12. Load a chain of plugs into the die.
13. Load a prepared cable into the plug located below the punches and push all the way forward. (see cable preparation instructions) Depress the foot switch on the press and remove the completed plug at the right end of the die guard. Inspect for proper termination depth and strain relief latching. (see fig.1)
14. Re adjust if necessary.

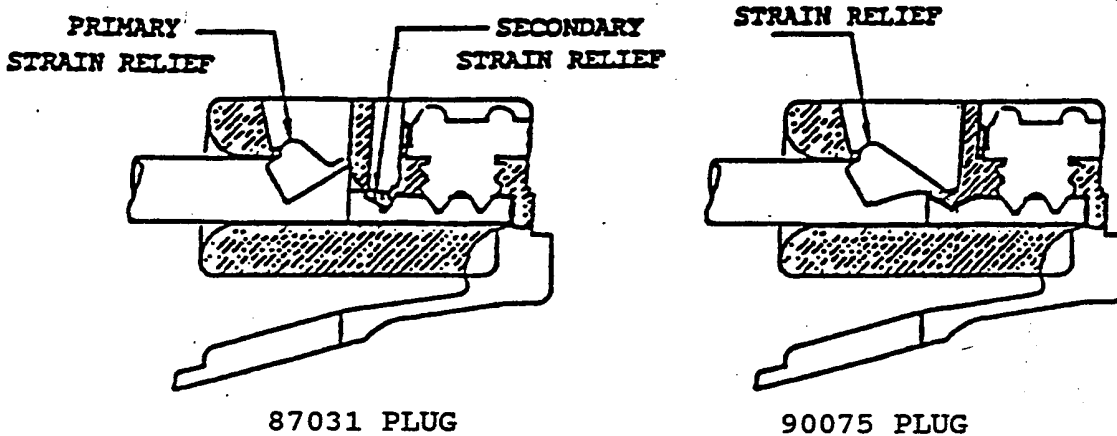

FIG. 1

CABLE PREPARATION:

To assemble a plug to a cable you must first strip the outer jacket of the cable to a length of 7.05mm max - 6.35mm min / .277" max - .25" min. Wires should be equal in length within 0.4mm / .016" without damage to the individual wire insulation.



APPLICATOR NO. 63181 T1 11-20-1259
 PRODUCT NO. 90075 - 8/8 KEYED SHORT BODY

SRL.NO.

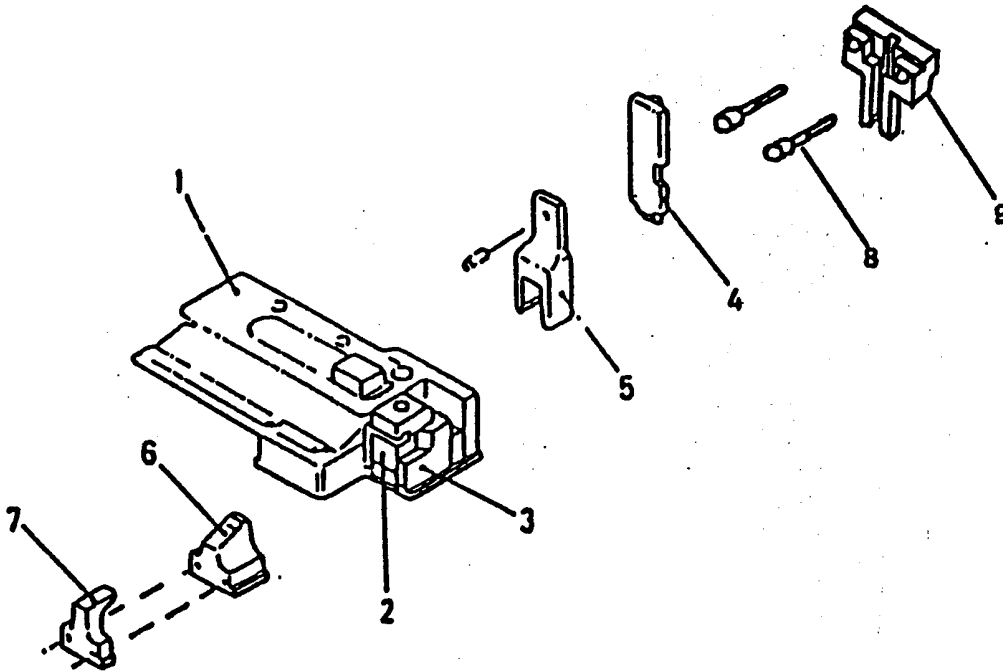

ITEM	PART NUMBER	DESCRIPTION
1	69017-0010	BASE MODULE (INC. ITEMS 2 & 3)
2	69017-0017	SHEAR PUNCH
3	69017-0018	SHEAR DIE
4	11-32-4721	TERMINATION PUNCH
5	11-32-4722	S.R. PUNCH
6	69017-0036	PLUG SUPPORT (REAR)
7	69017-0035	PLUG SUPPORT (FRONT)
8	69901-1416	SOC HD CAP SCRS M4 X 16 LONG
9	11-32-4723	CONNECTOR GUIDE PUNCH
10		TOOL KIT (ITEMS 4 - 9)

A
B

C

APPLICATOR NO. 63181 TZ 11-20-1260
 PRODUCT NO. 90075 - 8/6 KEYED SHORT BODY



SRL.NO.

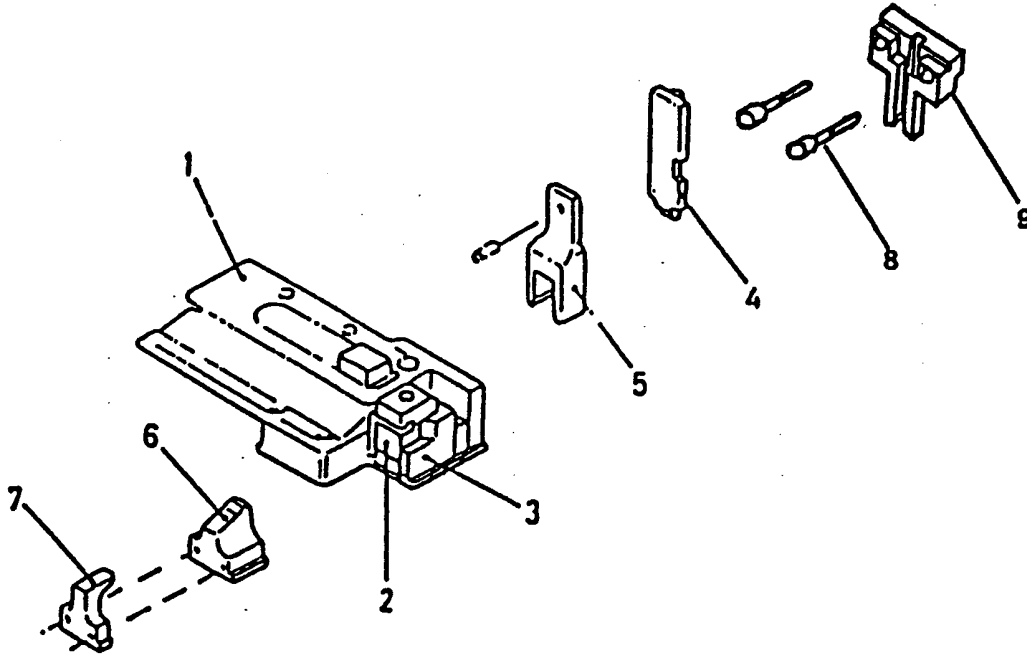

ITEM	PART NUMBER	DESCRIPTION
1	69017-0010	BASE MODULE (INC. ITEMS 2 & 3)
2	69017-0017	SHEAR PUNCH
3	69017-0018	SHEAR DIE
4	11-32-4724	TERMINATION PUNCH
5	11-32-4722	S.R.PUNCH
6	69017-0036	PLUG SUPPORT (REAR)
7	69017-0035	PLUG SUPPORT (FRONT)
8	69901-1416	SOC HD CAP SCREWS M4 X 16 LONG
9	11-32-4725	CONNECTOR GUIDE PUNCH
10		TOOL KIT (ITEMS 4 - 9)

D
 B
 E



APPLICATOR NO. 63181 T3 11-20-1261
 PRODUCT NO. 90075 8/8 NON-KEYED SHORT BODY

SRL.NO.

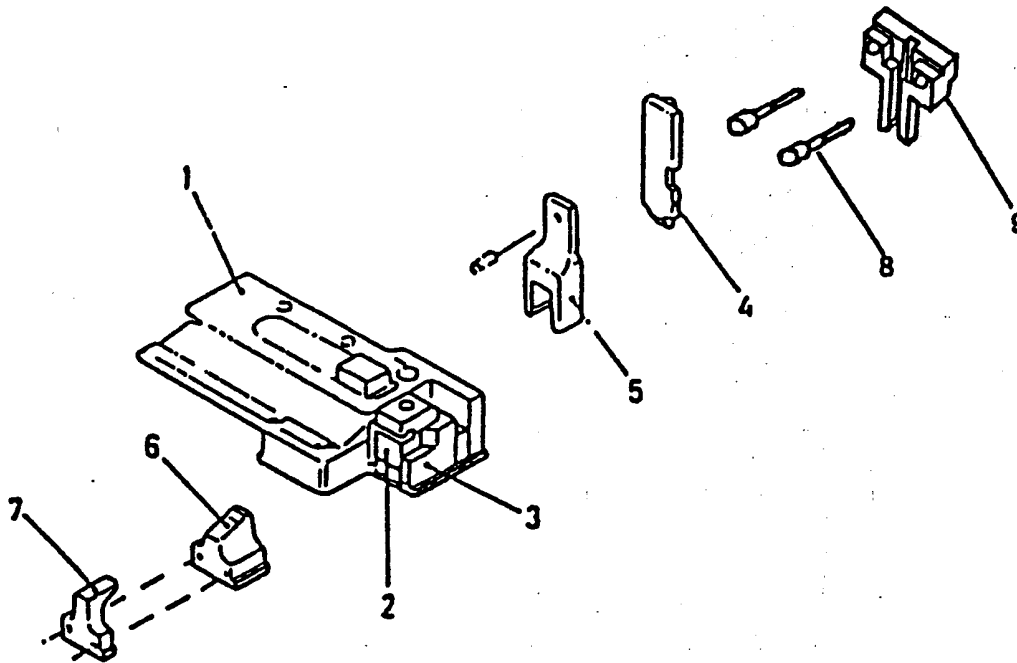

ITEM	PART NUMBER	DESCRIPTION
1	69017-0010	BASE MODULE (INC. ITEMS 2 & 3)
2	69017-0017	SHEAR PUNCH
3	69017-0018	SHEAR DIE
4	11-32-4721	TERMINATION PUNCH
5	11-32-4726	S.R. PUNCH
6	69017-0036	PLUG SUPPORT (REAR)
7	69017-0035	PLUG SUPPORT (FRONT)
8	69901-1416	SOC HD CAP SCRS M4 X 16 LONG
9	11-32-4727	CONNECTOR GUIDE PUNCH
10		TOOL KIT (ITEMS 4 - 9)

A

F

G



APPLICATOR NO. 63181 T4 11-20-1262
 PRODUCT NO. 90075 - 8/6 NON-KEYED SHORT BODY

SRL/NO.

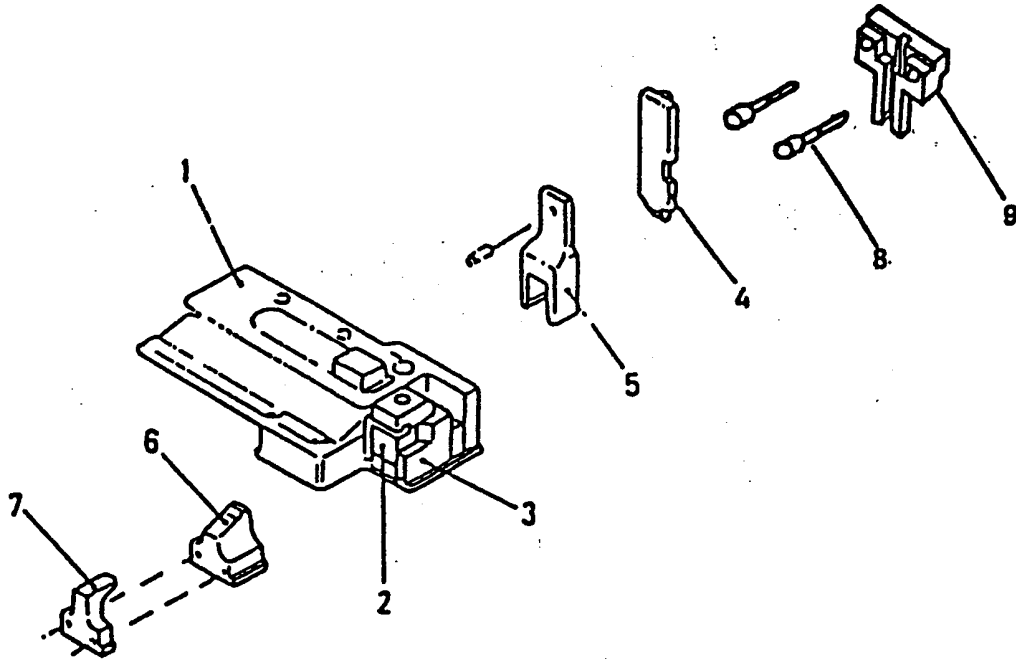

ITEM	PART NUMBER	DESCRIPTION
1	69017-0010	BASE MODULE (INC. ITEMS 2 & 3)
2	69017-0017	SHEAR PUNCH
3	69017-0018	SHEAR DIE
4	11-32-4724	TERMINATION PUNCH
5	11-32-4726	S.R. PUNCH
6	69017-0036	PLUG SUPPORT (REAR)
7	69017-0035	PLUG SUPPORT (FRONT)
8	69901-1416	SOC HD CAP SCRS M4 X 16 LONG
9	11-32-4728	CONNECTOR GUIDE PUNCH
10		TOOL KIT (ITEMS 4 - 9)

D
 F
 H

APPLICATOR No. 63181T5 11-20-1263

PRODUCT No. 87031 - 6/6 VERSION.



SRL NO.

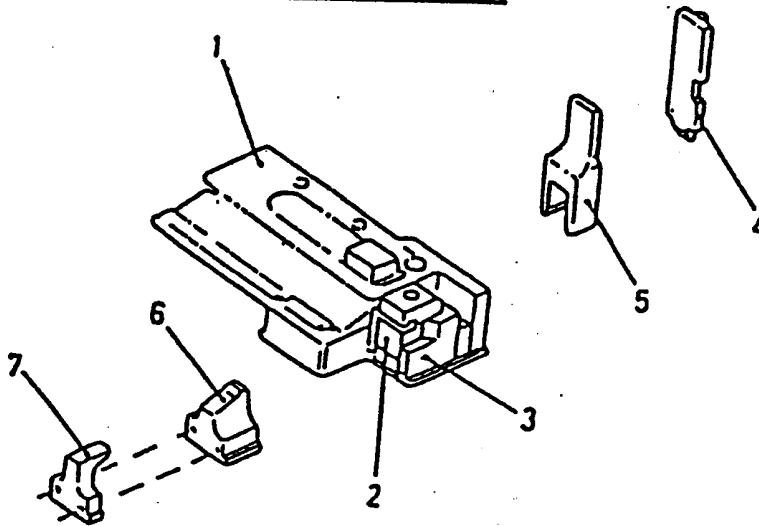

ITEM	PART NUMBER	DESCRIPTION
1	69017-0010	BASE MODULE (INC. ITEMS 2 & 3)
2	69017-0017	SHEAR PUNCH
3	69017-0018	SHEAR DIE
4	11-32-4729	TERMINATION PUNCH
5	↓	LATCHING PUNCH ASSY
5A	11-32-4730	LATCHING PUNCH
5B	69017-0152	SECONDARY LATCHING INSERT
6	69017-0057	PLUG SUPPORT (REAR)
7	69017-0056	PLUG SUPPORT (FRONT)
8		TOOL KIT (ITEMS 4-7)

1
J

APPLICATOR No. 63181 T6 11-20-1264

PRODUCT No. 87031 -6/3 & 6/4 VERSIONS.



SRL NO.

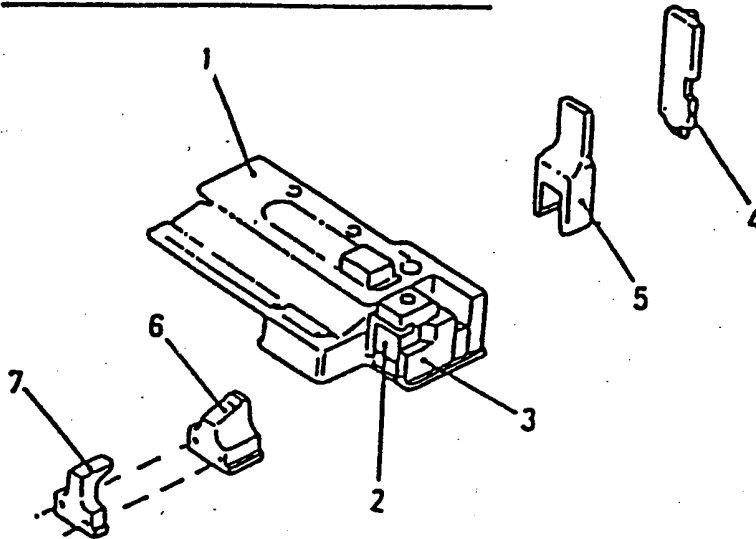

ITEM	PART NUMBER	DESCRIPTION
1	69017-0010	BASE MODULE (INC. ITEMS 2 & 3)
2	69017-0017	SHEAR PUNCH
3	69017-0018	SHEAR DIE
4	11-32-4731	TERMINATION PUNCH
5	↓	LATCHING PUNCH ASSY
5A	11-32-4730	LATCHING PUNCH
5B	69017-0152	SECONDARY LATCHING INSERT
6	69017-0057	PLUG SUPPORT (REAR)
7	69017-0056	PLUG SUPPORT (FRONT)
8		TOOL KIT (ITEMS 4-7)

K

J

APPLICATOR No. 63181 T7 11-20-1265

PRODUCT No. 87031 - 6/2 VERSION.



SRL NO.

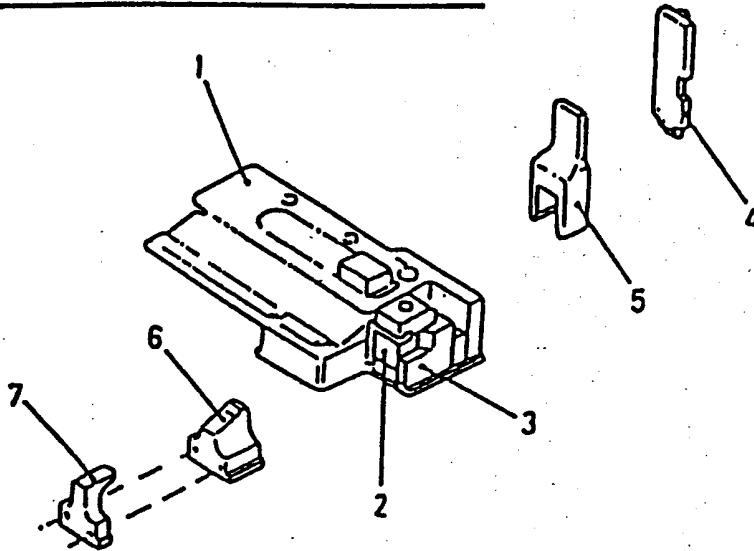

ITEM	PART NUMBER	DESCRIPTION
1	69017-0010	BASE MODULE (INC. ITEMS 2 & 3)
2	69017-0017	SHEAR PUNCH
3	69017-0018	SHEAR DIE
4	11-32-4732	TERMINATION PUNCH
5	↓	LATCHING PUNCH ASSY
5A	11-32-4730	LATCHING PUNCH
5B	69017-0152	SECONDARY LATCHING INSERT
6	69017-0057	PLUG SUPPORT (REAR)
7	69017-0056	PLUG SUPPORT (FRONT)
8		TOOL KIT (ITEMS 4-7)

L

J

APPLICATOR No. 63181 T8 11-20-1266

PRODUCT No. 87031 - 4/4 VERSION.



SRL NO.

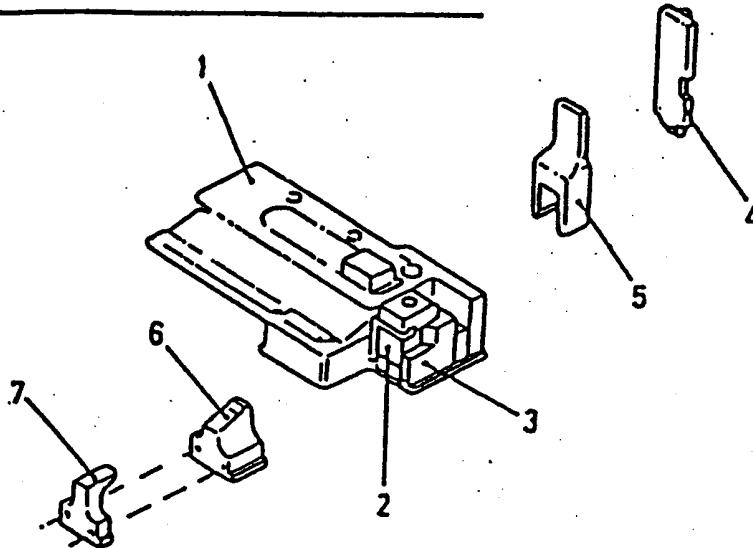

ITEM	PART NUMBER	DESCRIPTION
1	69017-0010	BASE MODULE (INC. ITEMS 2 & 3)
2	69017-0017	SHEAR PUNCH
3	69017-0018	SHEAR DIE
4	11-32-4731	TERMINATION PUNCH
5	↓	LATCHING PUNCH ASSY
5A	11-32-4733	LATCHING PUNCH
5B	69017-0152	SECONDARY LATCHING INSERT
6	69017-0081	PLUG SUPPORT (REAR)
7	69017-0080	PLUG SUPPORT (FRONT)
8		TOOL KIT (ITEMS 4-7)

K
M

APPLICATOR No. 63181T9 11-20-1267

PRODUCT No. 87031 - 4/2 VERSION.



SRL NO.

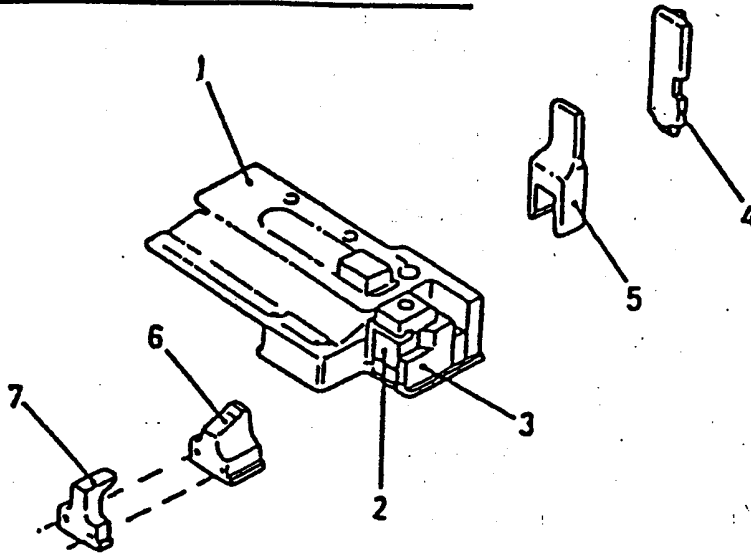

ITEM	PART NUMBER	DESCRIPTION
1	69017-0010	BASE MODULE (INC. ITEMS 2 & 3)
2	69017-0017	SHEAR PUNCH
3	69017-0018	SHEAR DIE
4	11-32-4732	TERMINATION PUNCH
5	↓	LATCHING PUNCH ASSY
5A	11-32-4733	LATCHING PUNCH
5B	69017-0152	SECONDARY LATCHING INSERT
6	69017-0081	PLUG SUPPORT (REAR)
7	69017-0080	PLUG SUPPORT (FRONT)
8		TOOL KIT (ITEMS 4-7)

L
M



ITEM No	DRAWING No.	SIZE	QTY	DESCRIPTION	REMARKS
1	69017-0014	B	1	BASE BLOCK	
2	69017-0015	B	1	STRIP SUPPORT PLATE	
3	69017-0017	A	1	SHEAR PUNCH	
4	69017-0018	B	1	SHEAR DIE	
5	69017-0019	B	1	FEED FINGER	
6	69017-0020	B	1	STRIKER SUPPORT	
7	69017-0022	A	1	RETAINING PLATE	
8	69017-0073	B	1	GUIDE PLATE	
9	69017-0074	B	1	GUIDE PLATE	
10	69017-0082	A	1	PAWL BLOCK	
11	69017-0083	A	1	PAWL	
12					
13					
14					
15	69018-9529			SPRING-COMPRESSION	LEE LC 0450-7
16	69018-9904			SPRING-TORSION	LEE LTLO12A-4
17					
18					
19					
20	69901-1325		2	SCREW CAP HD M3x25	
21	69901-1330		2	SCREW CAP HD M3x30	
22	69901-1310		1	SCREW CAP HD M3x10	
23	69902-1525		1	SCREW BUTTON HD M5x25	
24	69902-1516		1	SCREW BUTTON HD M5x16	
25	69902-1310		2	SCREW BUTTON HD M3x10	
26	69902-1306		1	SCREW BUTTON HD M3x6	
27	69903-1408		1	SCREW C'SK HD M4x8	
28	69904-2520		1	SCREW SET DOG PT M5x20	
29	69904-3304		1	SCREW SET CUP PT M3x4	
30					
31	69809-1203		1	DOWEL $\phi 2 \times 3$	
32	69809-1110		1	DOWEL $\phi 2.5 \times 10$	
33					
34					

COMPILED TR.	TITLE PARTS LIST BASE APPLICATOR	DRAWING NUMBER. 69017-0010 PL ✓
-----------------	--	------------------------------------

DATE

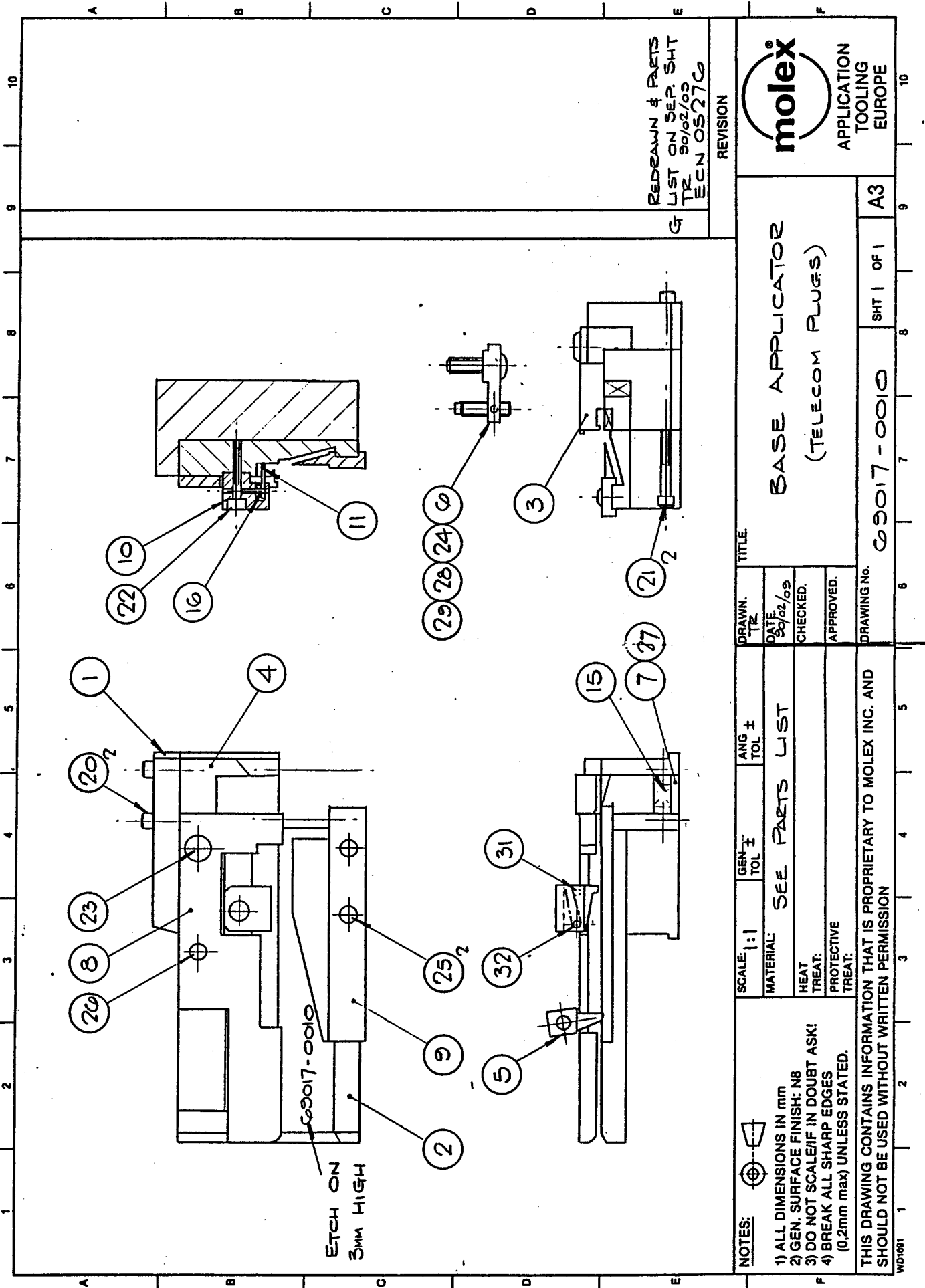

REDRAWN & PARTS LIST ON SEP. SHT TR 90/02/09 ECN 0527C

REVISION



APPLICATION TOOLING EUROPE

BASE APPLICATOR (TELECOM PLUGS)

TITLE

DRAWN. TR	DATE 90/02/09
CHECKED.	APPROVED.

DRAWING No. 09017-0010

SCALE: 1:1	GEN. TOL.	ANG. ± TOL.
MATERIAL: SEE PARTS LIST		
HEAT TREAT:		
PROTECTIVE TREAT:		
NOTES:		
1) ALL DIMENSIONS IN mm		
2) GEN. SURFACE FINISH: N8		
3) DO NOT SCALE IF IN DOUBT ASK!		
4) BREAK ALL SHARP EDGES (0.2mm max) UNLESS STATED.		
THIS DRAWING CONTAINS INFORMATION THAT IS PROPRIETARY TO MOLEX INC. AND SHOULD NOT BE USED WITHOUT WRITTEN PERMISSION		

SHT 1 OF 1

A3