

Excellent Integrated System Limited

Stocking Distributor

Click to view price, real time Inventory, Delivery & Lifecycle Information:

[Bivar, Inc.](#)
[CR-300](#)

For any questions, you can email us directly:
sales@integrated-circuit.com

REV.	DESCRIPTION	DATE	APPROVED
C	Engineering Update w/o Changes	02/26/04	M. C.
D	Remove Material Code	05/28/16	J. C.

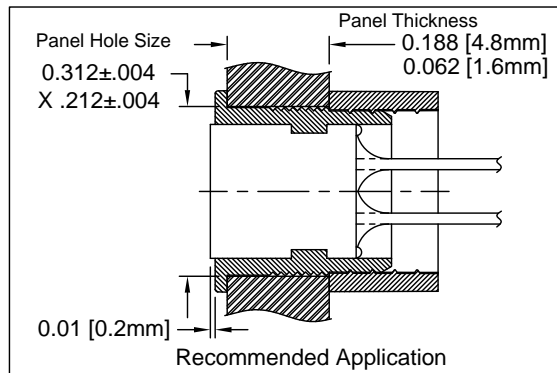
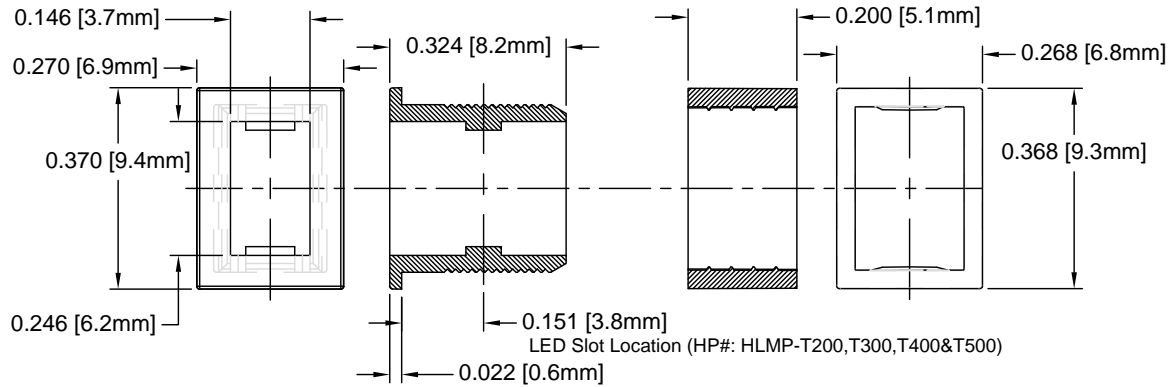

2. MATERIAL: NYLON 6/6, 94V-2, BLACK.

1. GENERAL SPECIFICATIONS: BIVAR MOLDED COMPONENT SPECIFICATION BV00-E101.

STANDARD TOLERANCE (UNLESS OTHERWISE SPECIFIED)		 4 THOMAS, IRVINE, CA. 92618 TEL: (949) 951-8808 FAX: (949) 951-3974			
DECIMALS	ANGULAR				
.X ±.1	X° ±1°	TITLE: CLIP & RING SET FOR RECTANGULAR LED			
.XX ±.01					
.XXX ±.005		DESIGNED: D. Green	DATE: 11/13/02	PART NO: CR-300	REVISION: D
		CHECKED: M. Chen	DATE: 11/13/02	CAGE CODE : 32559	SHEET # 1 OF 1
CAD GENERATED DOCUMENT, DO NOT MEASURE DRAWING.					