



## Excellent Integrated System Limited

Stocking Distributor

Click to view price, real time Inventory, Delivery & Lifecycle Information:

[Visual Communications Company, LLC](#)  
[CMD264-3ID/HV12](#)

For any questions, you can email us directly:

[sales@integrated-circuit.com](mailto:sales@integrated-circuit.com)

**T-1 Resistored LED Lamps**

**DESCRIPTION AND FEATURES**

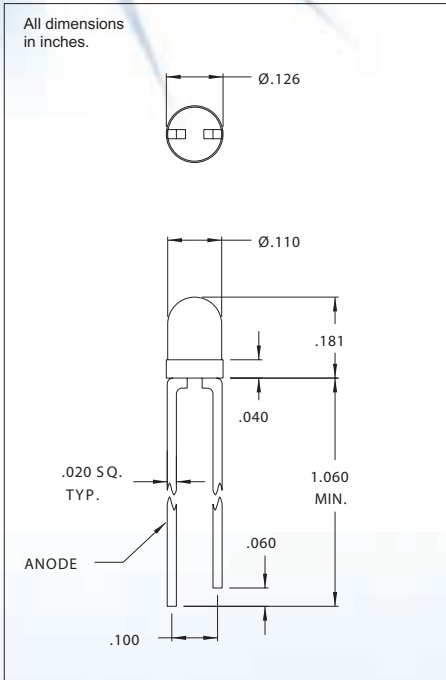

These T-1 LED lamps contain an integral resistor in series with the emitter chip to allow their direct application into 5 and 12 volt circuits. No external current limiting resistor is required. These lamps allow for savings in both component and assembly cost. These LEDs are compatible with all conventional soldering techniques.

**ELECTRO-OPTICAL CHARACTERISTICS**

Part Number	Emitted Color	Lens Color	Package Type	Luminous Intensity			Forward Voltage			Viewing Angle (degrees)	Peak Wavelength (nm)
				Min. (mcd)	Typ. (mcd)	Vf	Typ. (V)	Max. (V)	Vf		
CMD264-3ID/HV5	H.E. Red	Red	Diffused	9.0	13.0	5.0	10.0	15.0	5.0	40	635
CMD264-3GD/HV5	Green	Green	Diffused	8.0	12.0	5.0	10.0	15.0	5.0	40	565
CMD264-3YD/HV5	Yellow	Yellow	Diffused	6.0	9.0	5.0	10.0	15.0	5.0	40	585
CMD264-3ID/HV12	H.E. Red	Red	Diffused	9.0	13.0	12.0	10.0	20.0	12.0	40	635
CMD264-3GD/HV12	Green	Green	Diffused	8.0	12.0	12.0	10.0	20.0	12.0	40	565
CMD264-3YD/HV12	Yellow	Yellow	Diffused	6.0	9.0	12.0	10.0	20.0	12.0	40	585

**ABSOLUTE MAXIMUM RATINGS**

	5.0V	12.0V	Units
Operating/Storage Temperature.....	-40 to +85.....	-40 to +85.....	°C
Reverse Voltage (IR=100µA).....	5.0.....	5.0.....	V
Lead Solder Time @ 260°C.....	5.....	5.....	seconds
D.C. Forward Voltage.....	7.5.....	15.0.....	V