

## Excellent Integrated System Limited

Stocking Distributor

Click to view price, real time Inventory, Delivery & Lifecycle Information:

[Molex Connector Corporation](#)  
[0026481233](#)

For any questions, you can email us directly:

[sales@integrated-circuit.com](mailto:sales@integrated-circuit.com)

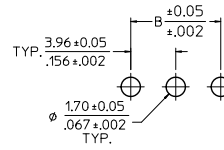
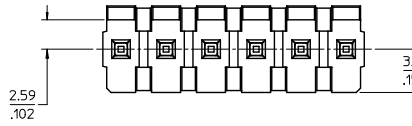
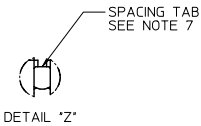

PCB LAYOUT COMPONENT SIDE  
RECOMMENDED PCB THICKNESS:  
1.57+0.18/.062+0.007

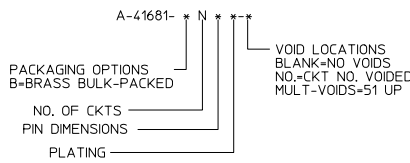
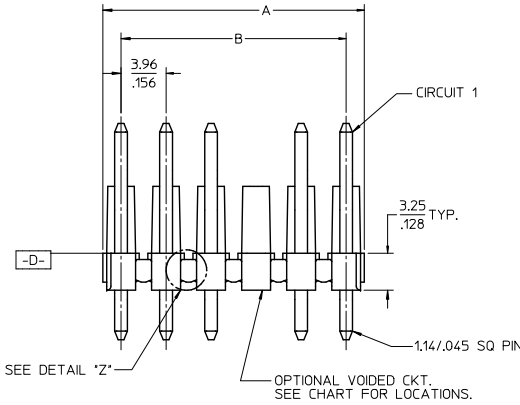
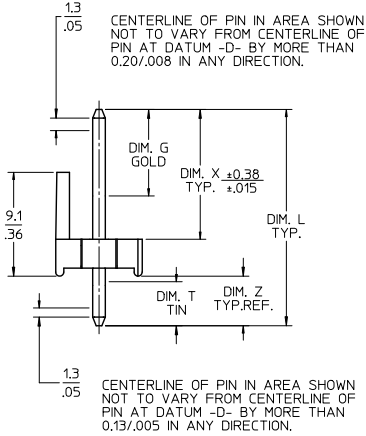

- NOTES:
- MATERIAL: HEADER: GLASS FILLED POLYESTER, 94V-0, MOLDED BLACK PINS- BRASS
  - FINISH:
    - (197) = OVERALL REFLOWED MATTE TIN: (0.00152)/.000060 MIN. OVER (0.00127)/.000050 MIN.
    - (208) = SELECT GOLD: (0.00038)/.000015 MIN. OVER
    - NICKEL OVERALL: (0.000127)/.000050 MIN.
    - (228) = SELECT GOLD: (0.00076)/.000030 MIN. OVER
    - NICKEL OVERALL: (0.000254)/.000100 MIN. OVER
    - (241) = SELECT GOLD: (0.00051)/.000020 MIN. OVER
    - NICKEL OVERALL: (0.000127)/.000050 MIN.
  - PRODUCT SPECIFICATION: PS-08-50.
  - PACKAGING: SEE CHART
  - SOLDERABILITY: PER SMES-152
  - PIN PUSH-OUT FORCE: PRIOR TO SOLDERING, A 3 LB. MINIMUM FORCE IN EITHER DIRECTION SHALL BE REQUIRED TO PUSH THE PIN OUT OF THE HEADER.
  - PARTS ARE STACKABLE END TO END ON 3.96/.156 CENTERS. (SPACING TABS MUST BE REMOVED ON CIRCUIT SIZES 1-23 BEFORE PARTS ARE STACKABLE.)

CIRCUIT	A		B	
	mm	inch	mm	inch
2	6.78/7.87	.267/.310	3.96	.156
3	10.74/11.84	.423/.466	7.92	.312
4	14.71/15.80	.579/.622	11.89	.468
5	18.67/19.76	.735/.778	15.85	.624
6	22.63/23.72	.891/.934	19.81	.780
7	26.59/27.69	1.047/1.090	23.77	.936
8	30.56/31.65	1.203/1.246	27.74	1.092
9	34.52/35.61	1.359/1.402	31.70	1.248
10	38.48/39.57	1.515/1.558	35.66	1.404
11	42.44/43.54	1.671/1.714	39.62	1.560
12	46.41/47.50	1.827/1.870	43.58	1.716
13	50.37/51.46	1.983/2.026	47.54	1.872
14	54.33/55.42	2.139/2.182	51.51	2.028
15	58.29/59.39	2.295/2.338	55.47	2.184
16	62.26/63.35	2.451/2.494	59.44	2.340
17	66.22/67.31	2.607/2.650	63.40	2.496
18	70.18/71.27	2.763/2.806	67.36	2.652
19	74.14/75.23	2.919/2.962	71.32	2.808
20	78.11/79.20	3.075/3.118	75.29	2.964
21	82.07/83.16	3.231/3.274	79.25	3.120
22	86.03/87.12	3.387/3.430	83.21	3.276
23	89.94/91.08	3.541/3.584	87.17	3.432
24	93.85/95.00	3.695/3.740	91.14	3.588

2-*	T
1	T
SHT.	REV.

ADD FINISH 197 EC NO: UCP202-0114 DRAWN BY: CHAKRABARTI CHECKED BY: APPRENTICE DATE: 2011/07/26 DATE: 2011/07/27 DATE: 2011/07/28	QUALITY SYMBOLS ∇=0 ∇=0 ∇=0	GENERAL TOLERANCES (UNLESS SPECIFIED) mm INCH 4 PLACES ± --- ± --- 3 PLACES ± --- ± .006 2 PLACES ± 0.15 ± .010 1 PLACE ± 0.25 ± --- ANGULAR ±1/2°	DIMENSION STYLE MM/IN	SCALE 4:1	DESIGN UNITS INCH	THIRD ANGLE PROJECTION	
		DRAWN BY: SAMIEC CHECKED BY: PATTEL APPROVED BY: LENZ DATE: 08/09/85 DATE: 08/09/85 DATE: 08/09/85	TITLE KK .156 HEADER ASSEMBLY POLARIZING STRAIGHT 2-24 CKTS.	MATERIAL NO. SEE CHART	DOCUMENT NO. SD-41681-001	SHEET NO. 1 OF *	
		DRAFT WHERE APPLICABLE MUST REMAIN WITHIN DIMENSIONS	THIS DRAWING CONTAINS INFORMATION THAT IS PROPRIETARY TO MOLEX INCORPORATED AND SHOULD NOT BE USED WITHOUT WRITTEN PERMISSION				
		MOLEX INCORPORATED					