

Excellent Integrated System Limited

Stocking Distributor

Click to view price, real time Inventory, Delivery & Lifecycle Information:

[Molex Connector Corporation](#)
[0300700625](#)

For any questions, you can email us directly:

sales@integrated-circuit.com

NATURAL HEADERS

30070-1232		12	GOLD	.1039	.827
30070-1235			TIN	(26.40)	(21.00)
30070-1032		10	GOLD	.874	.661
30070-1035			TIN	(22.20)	(16.80)
30070-0832		8	GOLD	.709	.496
30070-0835			TIN	(18.00)	(12.60)
30070-0632		6	GOLD	.543	.331
30070-0635			TIN	(13.80)	(8.40)
30070-0432		4	GOLD	.378	.165
30070-0435			TIN	(9.60)	(4.20)
30070-0232		2	GOLD	.213	
30070-0235			TIN	(5.40)	

BLACK HEADERS

30070-1212		12	GOLD	.1039	.827
30070-1215			TIN	(26.40)	(21.00)
30070-1012		10	GOLD	.874	.661
30070-1015			TIN	(22.20)	(16.80)
30070-0812		8	GOLD	.709	.496
30070-0815			TIN	(18.00)	(12.60)
30070-0612		6	GOLD	.543	.331
30070-0615			TIN	(13.80)	(8.40)
15-97-8048	30070-04B1	4	GOLD	.378	.165
15-97-8043	30070-04B3		TIN	(9.60)	(4.20)
15-97-8028	30070-02B1	2	GOLD	.213	
15-97-8023	30070-02B3		TIN	(5.40)	

PART NUMBER	ENG NUMBER	CKT. SIZE	PLATING	DIM 'A'	DIM 'B'
-------------	------------	-----------	---------	---------	---------

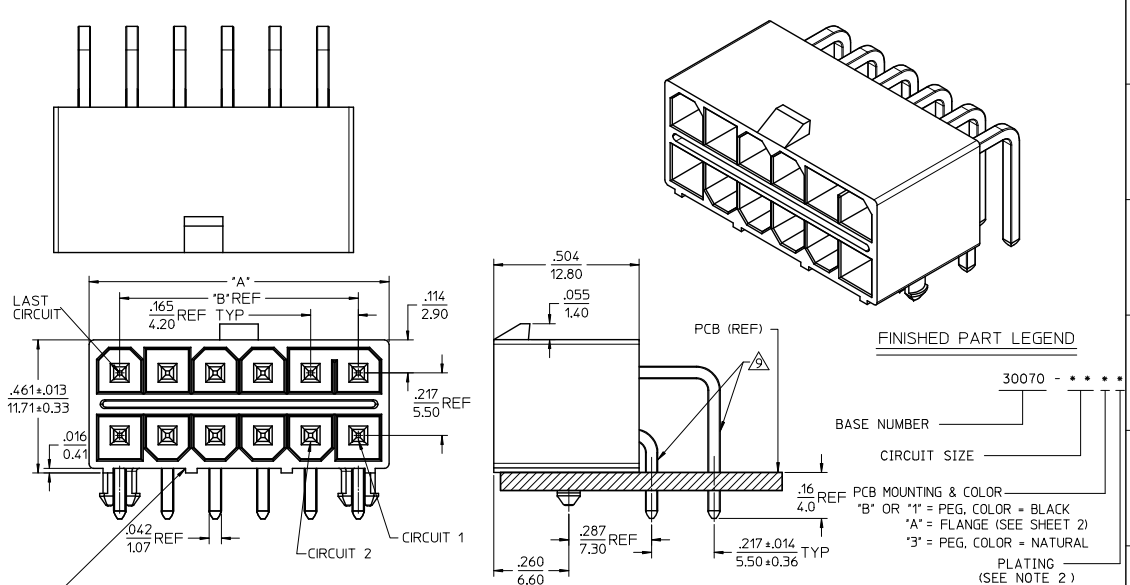

- NOTES:
- MATERIAL: HOUSING: POLYESTER, UNFILLED, UL94 V-0, COLOR: SEE CHART; TERMINALS: BRASS
 - TERMINAL PLATING: 3 OR 5-.000100/(0.00254) MIN. MATTE TIN OVER .000050/(0.00127) MIN. NICKEL; 1 OR 2-.000030/(0.00076) MIN. SELECT GOLD AND .000100/(0.00254) MIN. SELECT MATTE TIN OVER .000050/(0.00127) MIN. NICKEL OVERALL
 - PRODUCT SPECIFICATION: PS-5556-003
 - PACKAGING: BULK PER PK-30070-001
 - PART MATES WITH MINI-FIT JR. TPA RECEPTACLE 30067.
 - PARTS ARE NOT TO BE MATED OR UNMATED WHILE CIRCUITS ARE LIVE.
 - DISCOLORATION ON THE BANDOLIER CARRIER AREA OF THE PIN IS INHERENT TO THE PLATING PROCESS AND IS DUE TO THE MASKING EFFECT OF THE CARRIER. THIS DISCOLORATION IS IN A NON-FUNCTIONAL AREA OF THE PIN AND WILL NOT AFFECT THE PERFORMANCE OF THE HEADER ASSEMBLY.
 - PARTS CONFORM TO CLASS "B" REQUIREMENTS OF COSMETIC SPECIFICATION PS-45499-002.
 - FORMING MARKS ARE ACCEPTABLE.
 - PARTS ARE NOT DESIGNED FOR CURRENT SHARING.

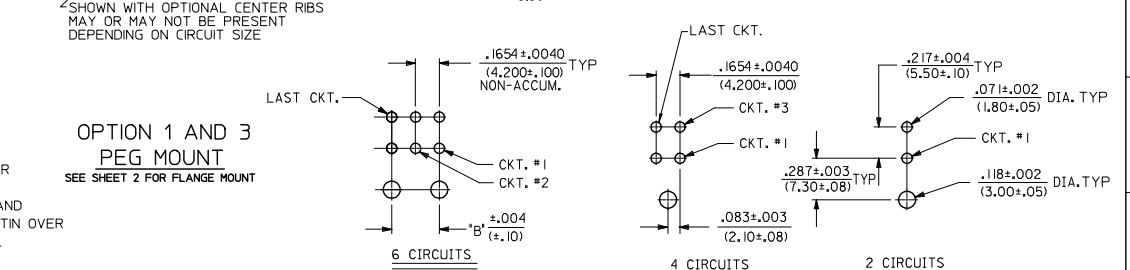

OPTION 1 AND 3 PEG MOUNT SEE SHEET 2 FOR FLANGE MOUNT

NOTE: DIMENSIONS SHOWN IN THIS VIEW ARE TYPICAL FOR ALL P.C.B. CONFIGURATIONS FROM 6-16 CIRCUITS.

RECOMMENDED HOLE LAYOUT FOR .070/(1.78) MAX. P.C.BOARD VIEWED FROM COMPONENT SIDE OF BOARD

QUALITY SYMBOLS	GENERAL TOLERANCES (UNLESS SPECIFIED)	DIMENSION STYLE	SCALE	DESIGN UNITS	THIRD ANGLE PROJECTION
▽=0	mm INCH	IN/MM	4:1	METRIC	
▽=0	4 PLACES ±.010	DRAWN BY T.GREGOR I	DATE 2006/03/28	TITLE MINI-FIT TPA RIGHT ANGLE HEADER ASSY	
▽=0	3 PLACES ±.014	CHECKED BY J.COMERC I	DATE 2006/03/28	APPROVED BY M.SMITH	
▽=0	2 PLACES ±.025	APPROVED BY M.SMITH	DATE 2010/04/09	MATERIAL NO. MOLEX INCORPORATED	
▽=0	1 PLACE ±.036	ANGULAR ±1/2°		DOCUMENT NO. SD-30070-001	
		DRAFT WHERE APPLICABLE MUST REMAIN WITHIN DIMENSIONS	SEE TABLE	SHEET NO. 1 OF 2	
				THIS DRAWING CONTAINS INFORMATION THAT IS PROPRIETARY TO MOLEX INCORPORATED AND SHOULD NOT BE USED WITHOUT WRITTEN PERMISSION	

