

Excellent Integrated System Limited

Stocking Distributor

Click to view price, real time Inventory, Delivery & Lifecycle Information:

[Fairchild Semiconductor](#)

[MM74C48N](#)

For any questions, you can email us directly:

sales@integrated-circuit.com



October 1987
Revised May 2002

MM74C48 BCD-to-7 Segment Decoder

General Description

The MM74C48 BCD-to-7 segment decoder is a monolithic complementary MOS (CMOS) integrated circuit constructed with N- and P-channel enhancement transistors. Seven NAND gates and one driver are connected in pairs to make binary-coded decimal (BCD) data and its complement available to the seven decoding AND-OR-INVERT gates. The remaining NAND gate and three input buffers provide test-blanking input/ripple-blanking output, and ripple-blanking inputs.

Features

- Wide supply voltage range: 3.0V to 15V
- Guaranteed noise margin: 1.0V
- High noise immunity: 0.45 V_{CC} (typ.)
- Low power TTL compatibility:
fan out of 2 driving 74L
- High current sourcing output (up to 50 mA)
- Ripple blanking for leading or trailing zeros (optional)
- Lamp test provision

Ordering Code:

Order Number	Package Number	Package Description
MM74C48N	N16E	16-Lead Plastic Dual-In-Line Package (PDIP), JEDEC MS-001, 0.300" Wide

Connection Diagrams

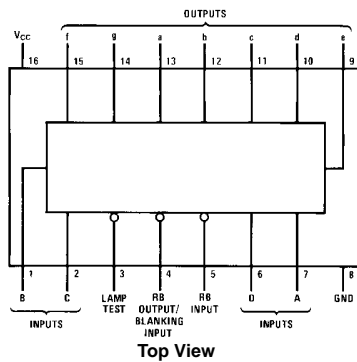

Segment Identification

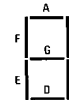

Numerical Designations and Resultant Displays

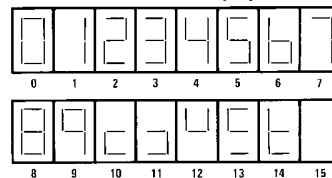

MM74C48

Truth Table

Decimal or Function	Inputs						BI/RBO (Note 1)	Outputs							Note
	LT	RBI	D	C	B	A		a	b	c	d	e	f	g	
0	H	H	L	L	L	L	H	H	H	H	H	H	L	(Note 2)	
1	H	X	L	L	L	H	H	L	H	H	L	L	L	(Note 2)	
2	H	X	L	L	H	L	H	H	H	L	H	H	L		
3	H	X	L	L	H	H	H	H	H	H	H	L	L		
4	H	X	L	H	L	L	H	L	H	H	L	L	H		
5	H	X	L	H	L	H	H	H	L	H	H	L	H		
6	H	X	L	H	H	L	H	L	L	H	H	H	H		
7	H	X	L	H	H	H	H	H	H	H	L	L	L		
8	H	X	H	L	L	L	H	H	H	H	H	H	H		
9	H	X	H	L	L	H	H	H	H	H	L	L	H		
10	H	X	H	L	H	L	H	L	L	L	H	H	L		
11	H	X	H	L	H	H	H	L	L	H	H	L	L		
12	H	X	H	H	L	L	H	L	H	L	L	L	H		
13	H	X	H	H	L	H	H	H	L	L	L	H	L		
14	H	X	H	H	H	L	H	L	L	L	H	H	H		
15	H	X	H	H	H	H	H	L	L	L	L	L	L		
BI	X	X	X	X	X	X	L	L	L	L	L	L	L	(Note 3)	
RBI	H	L	L	L	L	L	L	L	L	L	L	L	L	(Note 4)	
LT	L	X	X	X	X	X	H	H	H	H	H	H	H	(Note 5)	

H = HIGH Level
 L = LOW Level
 X = Irrelevant

Note 1: One BI/RBO is wire-AND logic serving as blanking input (BI) and/or ripple-blanking output (RBO).

Note 2: The blanking input (BI) must be open when output functions 0–15 are desired. The ripple-blanking input (RBI) must be HIGH, if blanking of a decimal zero is not desired.

Note 3: When a LOW logic level is applied directly to the blanking input (BI), all segment outputs are LOW regardless of the level of any other input.

Note 4: When ripple-blanking input (RBI) and inputs A, B, C, and D are at a LOW level with the lamp-test input HIGH, all segment outputs go LOW and the ripple-blanking output (RBO) goes to a LOW level (response condition).

Note 5: When the blanking input/ripple-blanking output (BI/RBO) is open and a LOW is applied to the lamp-test input, all segment outputs are HIGH.

Symbol	Parameter	Conditions	Min	Typ	Max	Units
Absolute Maximum Ratings (Note 6)						
	Voltage at Any Pin	-0.3V to $V_{CC} + 0.3V$				
	Operating Temperature Range	-55°C to +125°C				
	Storage Temperature Range	-65°C to +150°C				
	Power Dissipation					
	Dual-In-Line	700 mW				
	Small Outline	500 mW				
	Operating V_{CC} Range	3.0V to 15V				
	Absolute Maximum V_{CC}	18V				
	Lead Temperature					
	(Soldering, 10 seconds)	260°C				
<p>Note 6: "Absolute Maximum Ratings" are those values beyond which the safety of the device cannot be guaranteed. Except for "Operating Temperature Range" they are not meant to imply that the devices should be operated at these limits. The Electrical Characteristics table provides conditions for actual device operation.</p>						
DC Electrical Characteristics						
CMOS to CMOS						
$V_{IN(1)}$	Logical "1" Input Voltage	$V_{CC} = 5.0V$	3.5			V
		$V_{CC} = 10V$	8.0			
$V_{IN(0)}$	Logical "0" Input Voltage	$V_{CC} = 5.0V$			1.5	V
		$V_{CC} = 10V$			2.0	
$V_{OUT(1)}$	Logical "1" Output Voltage (RB Output Only)	$V_{CC} = 5.0V, I_O = -10 \mu A$	4.5			V
		$V_{CC} = 10V, I_O = -10 \mu A$	9.0			
$V_{OUT(0)}$	Logical "0" Output Voltage	$V_{CC} = 5.0V, I_O = 10 \mu A$			0.5	V
		$V_{CC} = 10V, I_O = 10 \mu A$			1.0	
$I_{IN(1)}$	Logical "1" Input Current	$V_{CC} = 15.0V, V_{IN} = 15V$		0.005	1.0	μA
$I_{IN(0)}$	Logical "0" Input Current	$V_{CC} = 15.0V, V_{IN} = 0V$	-1.0	-0.005		μA
I_{CC}	Supply Current	$V_{CC} = 15V$		0.05	300	μA
CMOS/LPTTL INTERFACE						
$V_{IN(1)}$	Logical "1" Input Voltage	$V_{CC} = 4.75V$	$V_{CC} - 1.5$			V
$V_{IN(0)}$	Logical "0" Input Voltage	$V_{CC} = 4.75V$			0.8	V
$V_{OUT(1)}$	Logical "1" Output Voltage (RB Output Only)	$V_{CC} = 4.75V, I_O = -50 \mu A$	2.4			V
$V_{OUT(0)}$	Logical "0" Output Voltage	$V_{CC} = 4.75V, I_O = 360 \mu A$			0.4	V
OUTPUT DRIVE (See Family Characteristics Data Sheet)						
I_{SOURCE}	Output Source Current (P-Channel) (RB Output Only)	$V_{CC} = 4.75V, V_{OUT} = 0.4V$			-0.80	mA
		$V_{CC} = 10V, V_{OUT} = 0.5V$			-4.0	
I_{SINK}	Output Sink Current (N-Channel)	$V_{CC} = 5.0V, V_{OUT} = V_{CC}$ $T_A = 25^\circ C$	1.75	3.6		mA
I_{SINK}	Output Sink Current (N-Channel)	$V_{CC} = 10V, V_{OUT} = V_{CC}$ $T_A = 25^\circ C$	8.0	16		mA
I_{SOURCE}	Output Source Current (NPN Bipolar)	$V_{CC} = 5.0V, V_{OUT} = 3.4V$	-20	-50		mA
		$V_{CC} = 5.0V, V_{OUT} = 3.0V$		-65		
		$V_{CC} = 10V, V_{OUT} = 8.4V$	-20	-50		
		$V_{CC} = 10V, V_{OUT} = 8.0V$		-65		

MM74C48

AC Electrical Characteristics (Note 7)

$T_A = 25^\circ\text{C}$, $C_L = 50\text{ pF}$, unless otherwise specified

Symbol	Parameter	Conditions	Min	Typ	Max	Units
t_{pd0} , t_{pd1}	Propagation Delay to a "1" or "0" on Segment Outputs from Data Inputs	$V_{CC} = 5.0\text{V}$		450	1500	ns
		$V_{CC} = 10\text{V}$		160	500	
t_{pd0}	Propagation Delay to a "0" on Segment Outputs from RB Input	$V_{CC} = 5.0\text{V}$		500	1600	ns
		$V_{CC} = 10\text{V}$		180	550	
t_{pd0}	Propagation Delay to a "0" on Segment Outputs from Blanking Input	$V_{CC} = 5.0\text{V}$		350	1200	ns
		$V_{CC} = 10\text{V}$		140	450	
t_{pd1}	Propagation Delay to a "1" on Segment Outputs from Lamp Test	$V_{CC} = 5.0\text{V}$		450	1500	ns
		$V_{CC} = 10\text{V}$		160	500	
t_{pd1}	Propagation Delay to a "1" on RB Output from RB Input	$V_{CC} = 5.0\text{V}$		600	2000	ns
		$V_{CC} = 10\text{V}$		250	800	
t_{pd0}	Propagation Delay to a "0" on RB Output from RB Input	$V_{CC} = 5.0\text{V}$		140	450	ns
		$V_{CC} = 10\text{V}$		50	150	

Note 7: AC Parameters are guaranteed by DC correlated testing.

Typical Applications

Typical Connection Utilizing the Ripple-Blanking Feature

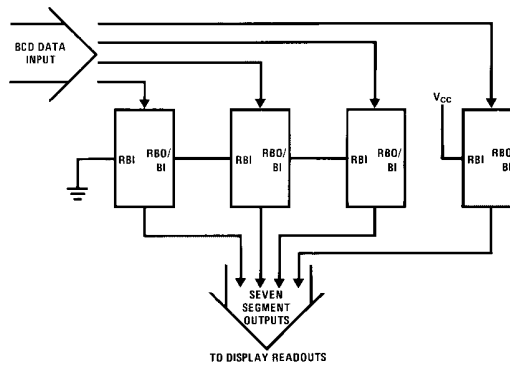

First three stages will blank leading zeros, the fourth stage will not blank zeros.

Blanking Input Connection Diagram

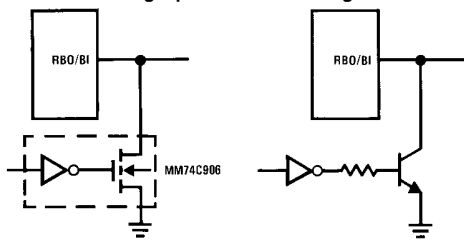

When RBO/BI is forced LOW, all segment outputs are off regardless of the state of any other input condition.

Light Emitting Diode (LED) Readout

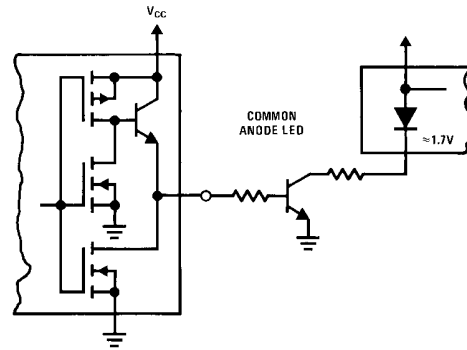
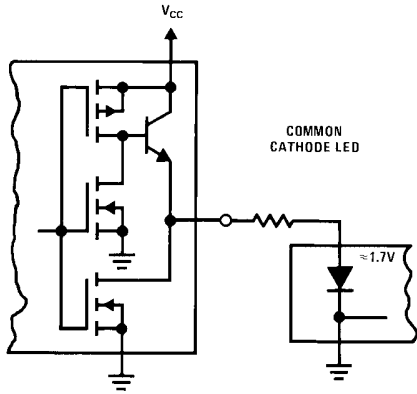

Incandescent Readout

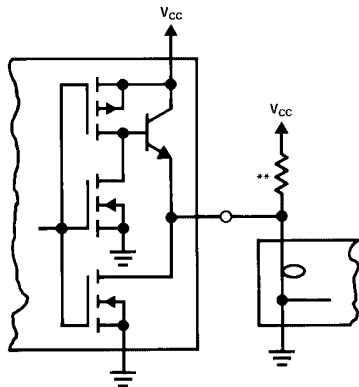

Fluorescent Readout

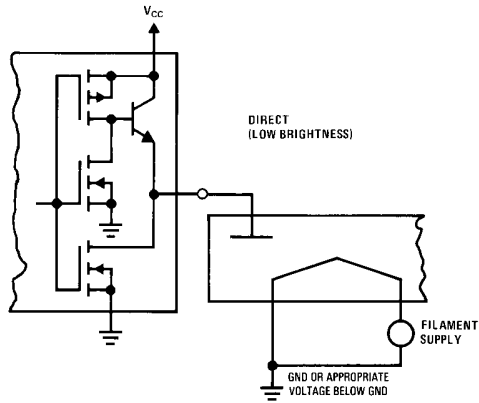

**A filament pre-warm resistor is recommended to reduce filament thermal shock and increase the effective cold resistance of the filament.

Gas Discharge Readout

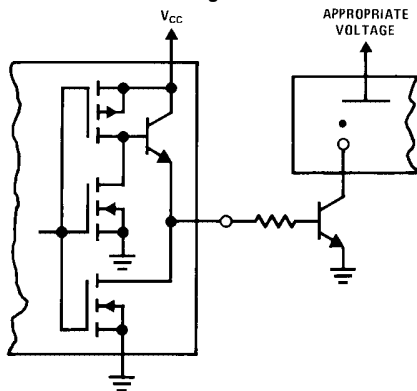

Liquid Crystal (LC) Readout

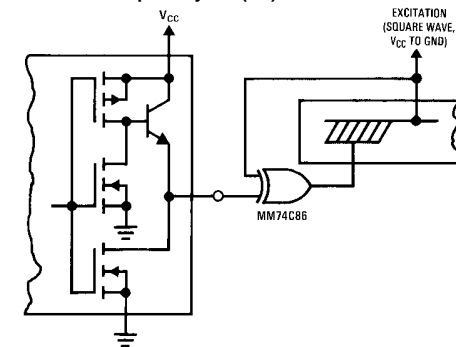

Direct DC drive of LC's not recommended for life of LC readouts.

MM74C48 BCD-to-7 Segment Decoder

Physical Dimensions inches (millimeters) unless otherwise noted

16-Lead Plastic Dual-In-Line Package (PDIP), JEDEC MS-001, 0.300" Wide Package Number N16E

Fairchild does not assume any responsibility for use of any circuitry described, no circuit patent licenses are implied and Fairchild reserves the right at any time without notice to change said circuitry and specifications.

LIFE SUPPORT POLICY

FAIRCHILD'S PRODUCTS ARE NOT AUTHORIZED FOR USE AS CRITICAL COMPONENTS IN LIFE SUPPORT DEVICES OR SYSTEMS WITHOUT THE EXPRESS WRITTEN APPROVAL OF THE PRESIDENT OF FAIRCHILD SEMICONDUCTOR CORPORATION. As used herein:

1. Life support devices or systems are devices or systems which, (a) are intended for surgical implant into the body, or (b) support or sustain life, and (c) whose failure to perform when properly used in accordance with instructions for use provided in the labeling, can be reasonably expected to result in a significant injury to the user.
2. A critical component in any component of a life support device or system whose failure to perform can be reasonably expected to cause the failure of the life support device or system, or to affect its safety or effectiveness.

www.fairchildsemi.com