

Excellent Integrated System Limited

Stocking Distributor

Click to view price, real time Inventory, Delivery & Lifecycle Information:

[Comchip Technology](#)
[TB10S-G](#)

For any questions, you can email us directly:

sales@integrated-circuit.com

Silicon Bridge Rectifiers

TB2S-G Thru. TB10S-G

Reverse Voltage: 200 to 1000 Volts

Forward Current: 0.8, 1.0 A

RoHS Device

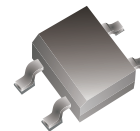

Features

- Glass passivated chip junction.
- High surge overload rating :30A peak
- Save space on printed circuit boards.
- High temperature soldering guaranteed:
260°C/10 seconds at 5 lbs.
- Pb free product.
- Plastic material has U/L flammability classification 94v-0.

Mechanical data

- Polarity: Symbol molded on body.
- Case: Molded plastic body over passivated junction.
- Terminals: Plated leads solderable per MIL-STD-750,
Method 2026.
- Mounting position: Any.

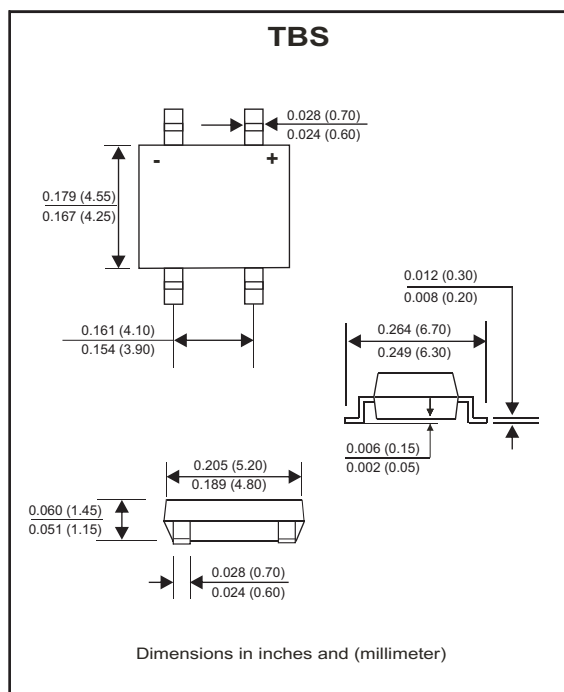

Maximum ratings and electrical characteristics

Rating at 25°C ambient temperature unless otherwise specified.
 Single phase, half wave ,60Hz, resistive or inductive load.
 For capacitive load, derate current by 20%

Parameter	Symbol	TB2S-G	TB4S-G	TB6S-G	TB8S-G	TB10S-G	Unit
	Marking	TB2S	TB4S	TB6S	TB8S	TB10S	
Maximum Recurrent Peak Reverse Voltage	V _{RRM}	200	400	600	800	1000	V
Maximum RMS Voltage	V _{RMS}	140	280	420	560	700	V
Maximum DC Blocking Voltage	V _{DC}	200	400	600	800	1000	V
Maximum Average Forward Output Current TL=100°C	I _{F(AV)}	0.8 ¹⁾ 1.0 ²⁾					A
Peak Forward Surge Current, 8.3ms Single Half Sine-wave, Superimposed on Rated Load (JEDEC Method)	I _{FSM}	30					A
Maximum Instantaneous Forward Voltage at 0.4A DC	V _F	0.95					V
Maximum Reverse Current @T _A =25°C at Rated DC Blocking Voltage	I _R	10					µA
Typical Thermal Junction to lead On aluminum substrate On glass-epoxy substrate	R _{θJL} R _{θJA}	25 62.5 80					°C/W
Operating Junction Temperature Range	T _J	-55 to +150					°C
Storage Temperature Range	T _{STG}	-55 to +150					°C

Notes: 1. On glass epoxy P.C.B
 2. On aluminum substrate

Silicon Bridge Rectifiers



RATING AND CHARACTERISTIC CURVES (TB2S-G thru TB10S-G)

Fig.1 - Typical Forward Characteristics

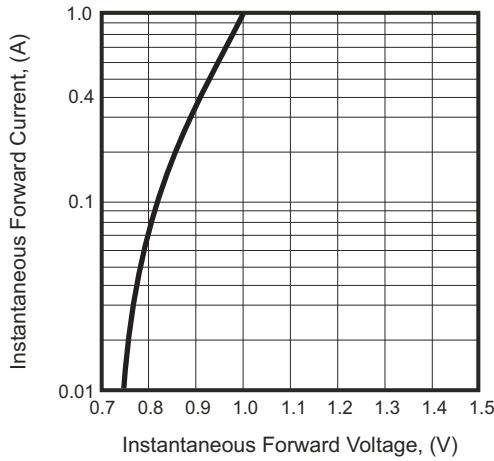

Fig.2 - Forward Derating Curve

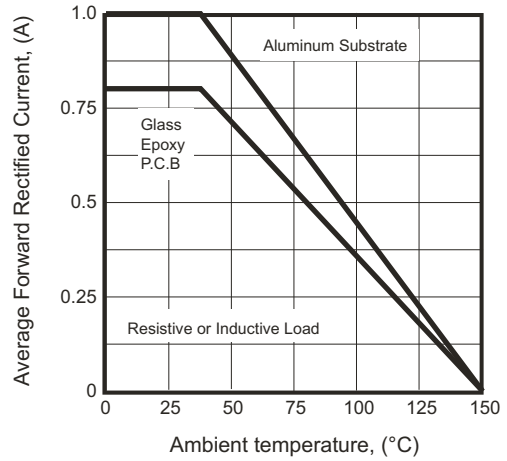

Fig.3 - Typical Reverse Characteristics

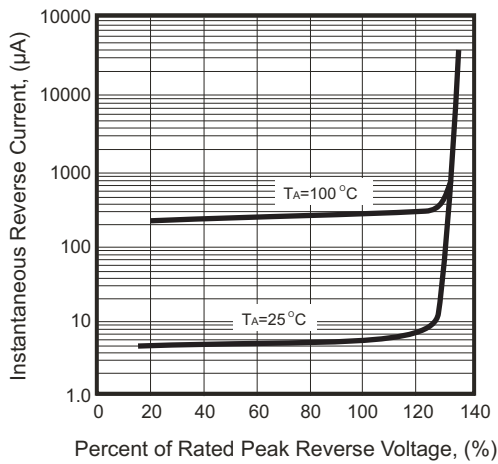
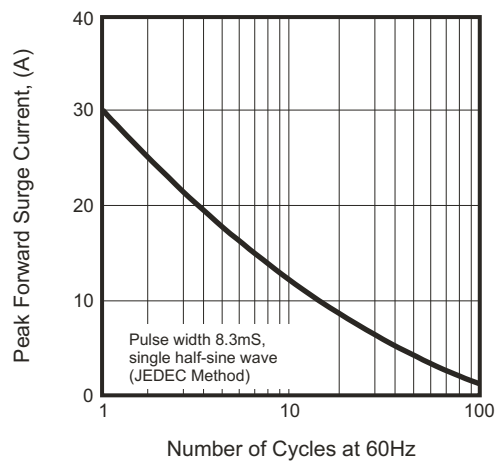

Fig.4 - Peak Forward Surge Current



Silicon Bridge Rectifiers



Reel Taping Specification

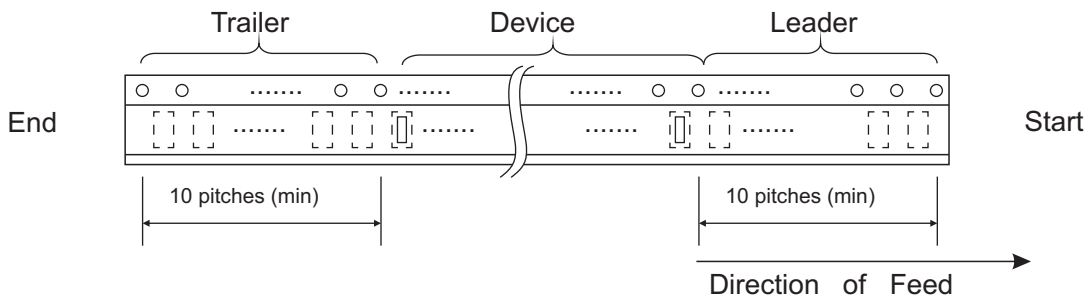
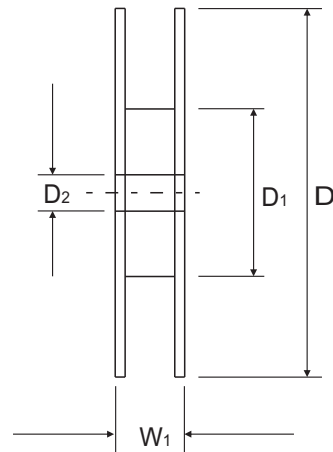
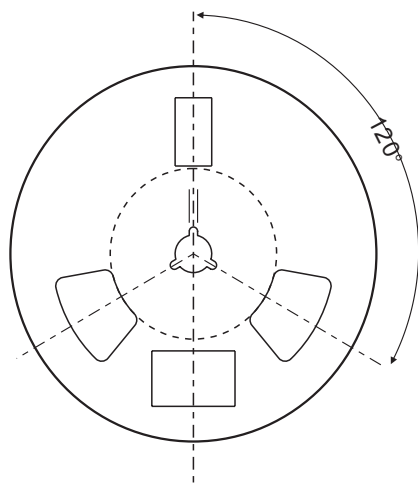
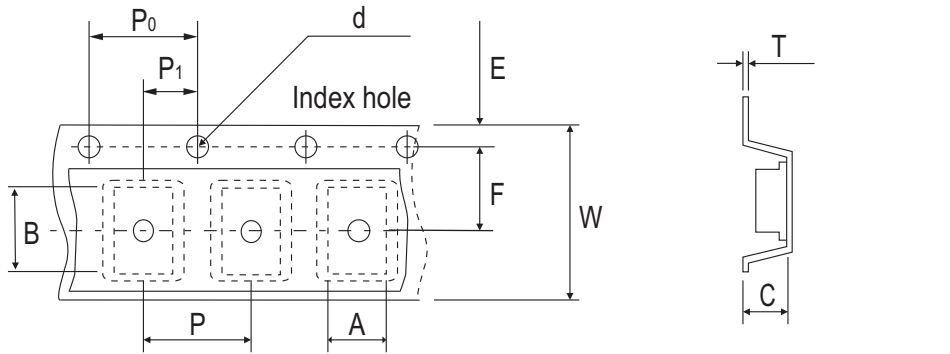

TBS	SYMBOL	A	B	C	d	D	D ₁	D ₂
	(mm)	5.50 ± 0.10	6.85 ± 0.10	2.10 ± 0.10	1.55 ± 0.05	330 ± 0.1	75 ± 0.1	13.0 ± 0.10
	(inch)	0.217 ± 0.004	0.270 ± 0.004	0.083 ± 0.004	0.061 ± 0.002	12.992 ± 0.004	2.953 ± 0.004	0.512 ± 0.004

TBS	SYMBOL	E	F	P	P ₀	P ₁	T	W	W ₁
	(mm)	1.75 ± 0.10	5.50 ± 0.10	8.00 ± 0.10	4.00 ± 0.10	2.00 ± 0.05	0.30 ± 0.05	12.00 ± 0.30	18.00 ± 0.1
	(inch)	0.069 ± 0.004	0.217 ± 0.004	0.315 ± 0.004	0.157 ± 0.004	0.079 ± 0.002	0.012 ± 0.002	0.472 ± 0.012	0.709 ± 0.004

Silicon Bridge Rectifiers

Suggested PAD Layout

SIZE	TBS	
	(mm)	(inch)
A	0.68MIN	0.027MIN
B	4.0±0.1	0.157±0.004
C	0.62MIN	0.024MIN
D	6.70MAX	0.264MAX

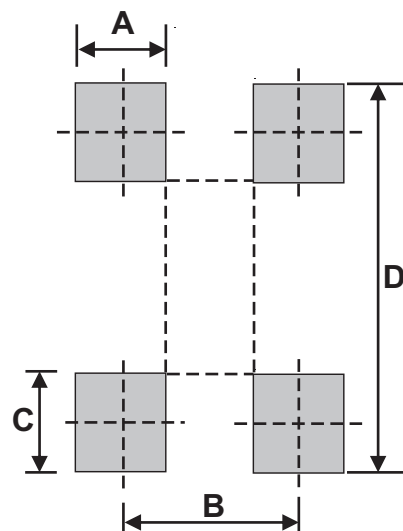

Standard Packaging

Case Type	REEL PACK	
	REEL (pcs)	Reel Size (inch)
TBS	1,500	13