

## Excellent Integrated System Limited

Stocking Distributor

Click to view price, real time Inventory, Delivery & Lifecycle Information:

[STMicroelectronics](#)  
[EVAL6393FB](#)

For any questions, you can email us directly:

[sales@integrated-circuit.com](mailto:sales@integrated-circuit.com)



## EVAL6393FB

Low voltage full-bridge demonstration board based on the L6393 advanced high voltage gate driver

Data brief

### Features

- ~150 W drive capability (50 V - 3.0 A<sub>r.m.s.</sub>)
- Very low area occupation, all devices and power switches in SMD package (no heatsink)
- Fast-decay or slow-decay on-board constant off-time peak current control
- PWM voltage mode control with overcurrent protection possible via external logic signals
- Driver supply voltage on-board generation directly from BUS voltage
- Carefully optimized layout



EVAL6393FB

### Description

The EVAL6393FB demonstrates how to use two L6393 drivers to drive a single-phase load through a full-bridge topology. This allows both the direction and the value of the current flowing into the load to be controlled. Typical loads, which can be effectively driven by using this topology, are single-phase BLDC motors, fans and HID lamps. Thanks to the integrated features of the L6393, the board has a very small footprint and an optimized layout, and can be simply run by applying the BUS voltage and a direction signal.

# 1 Board description

**Table 1. EVAL6393FB electrical specifications**

Parameter	Value
Supply voltage range (VS) <sup>(1) (2)</sup>	32 V to 52 V <sub>DC</sub>
RMS output current rating (OUT x)	Up to 3.0 A
Driver supply voltage (V <sub>CC</sub> ) <sup>(3)</sup>	10 to 20 V
Logic control signals	0 to + 15 V
Operating temperature range	-40 to +125 °C

1. Minimum VS voltage restriction is due to biasing current of the Zener diode used to generate V<sub>CC</sub>. This limit can be decreased by changing R29 value or by opening JP3 and providing an externally generated V<sub>CC</sub> through connector J1.
2. Maximum VS voltage limit can be increased up to 580 V by replacing the power switches and bulk capacitor C15 with components with adequate voltage ratings. Resistor R29 should be removed and an externally generated V<sub>CC</sub> should be provided through connector J1.
3. When externally supplied through J1 with JP3 opened, otherwise V<sub>CC</sub> = 12 V.

**Figure 1. Jumper and connector location**

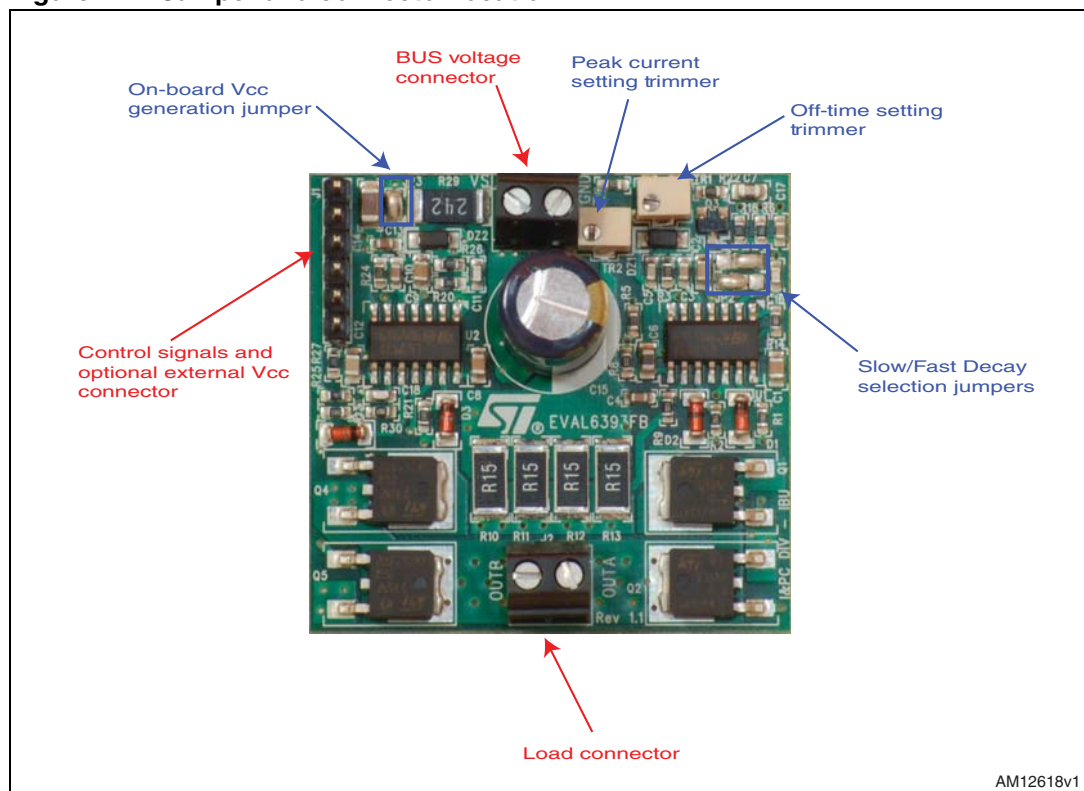

**Table 2. Jumper and connector description**

Name	Type	Function
J1	Control signal connector	Optional control signal and external V <sub>CC</sub> connector
J2	Power output	Load connector
J3	Power supply	BUS power supply connector
JP1	Configuration jumper	To pull-up SD and/or BRAKE signal to V <sub>CC</sub> /3
JP2	Configuration jumper	To pull-up SD and/or BRAKE signal to CPOUT
JP3	Configuration jumper	To connect the on-board generated V <sub>CC</sub> to the supply pins of the drivers

**Table 3. Control signal connector pinout (J1)**

Pin	Type	Description
1	Power supply	Driver power supply V <sub>CC</sub> , open JP3 to provide externally generated V <sub>CC</sub>
2	Power supply	GND
3	Digital input	Driver SD signal
4	Digital input	Driver BRAKE signal
5	Analog PWM input	V <sub>ctrl</sub> signal; used to change current limit threshold
6	Digital input	DIR signal; sets current direction

**Table 4. Current peak detection settings**

Pin	Type	Description
TR1	Variable resistor	Used to adjust constant off-time duration after overcurrent detection
TR2	Variable resistor	Used to adjust overcurrent detection threshold I <sub>pk</sub> $I_{pk} = V(CP-)/[R10//R11//R12//R13]$

**Table 5. Control scheme configuration**

Description	Jumper configuration
Constant off-time peak current control with slow-decay	JP1 closed on !SD and JP2 closed on !BRAKE
Constant off-time peak current control with fast-decay	JP1 closed on !SD and JP2 closed on !SD
PWM voltage control with slow-decay overcurrent protection	JP1 open, JP2 closed on !BRAKE and !SD externally provided through J1
PWM voltage control with fast-decay overcurrent protection	JP1 open, JP2 closed on !SD and !BRAKE externally provided through J1

Board description

EVAL6393FB

Figure 2. EVAL6393FB schematic

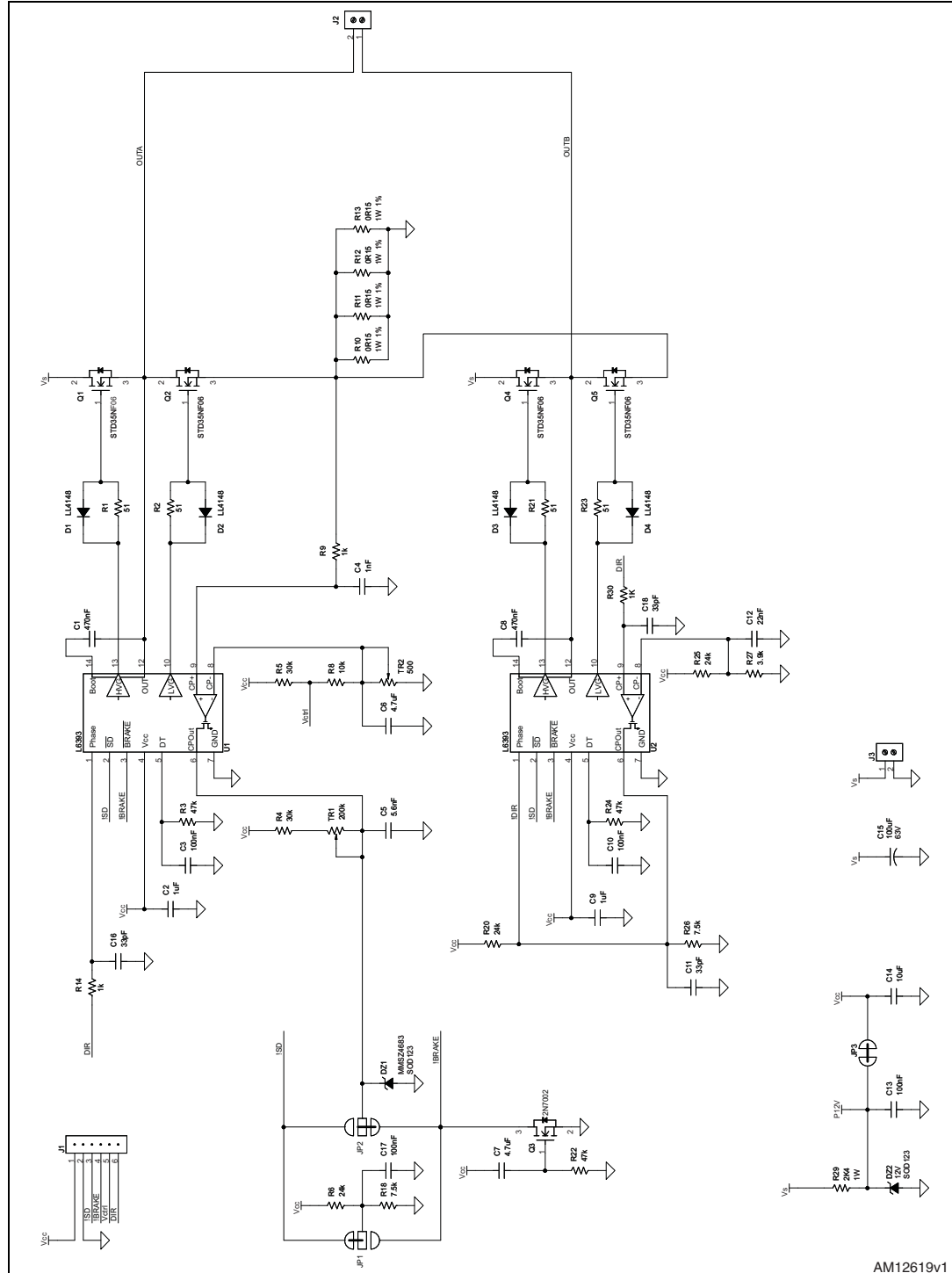

EVAL6393FB

Board description

**Table 6. EVAL6393FB bill of material**

Reference	Value	Description
C1, C8	470 nF, 25 V	SMT ceramic capacitor, 0805
C2, C9	1 $\mu$ F, 25 V	SMT ceramic capacitor, 0805
C3, C10, C13, C17	100 nF, 25 V	SMT ceramic capacitor, 0603
C4	1 nF, 25 V	SMT ceramic capacitor, 0603
C5	5.6 nF, 25 V	SMT ceramic capacitor, 0603
C6, C7	4.7 $\mu$ F	SMT ceramic capacitor, 0805
C11, C16, C18	33 pF, 25 V	SMT ceramic capacitor, 0603
C12	22 nF, 25 V	SMT ceramic capacitor, 0805
C14	10 $\mu$ F, 25 V	SMT ceramic capacitor, 1206
C15	100 $\mu$ F, 63 V	Radial lead electrolytic capacitor (D 10 mm, H 12.5 mm)
D1, D2, D3, D4	LL4148	Fast switching diode, SOD80
DZ1	MMSZ4683	3 V Zener diode, SOD123
DZ2		12 V Zener diode, SOD123
J1		1x6 strip, 2.54 mm pitch
J2, J3		1x2 screw PCB terminal block, 5.08 mm pitch
JP1, JP2		2- way solder jumper
JP3		Solder jumper
Q1, Q2, Q4, Q5	STD35NF06	60 V, 35 A N-channel power MOSFET in DPAK
Q3	2N7002	60 V, 0.2 A N-channel power MOSFET in SOT23
R1, R2, R21, R23	51 $\Omega$	SMT resistor, 0603
R3, R22, R24	47 k $\Omega$	SMT resistor, 0603
R4, R5	30 k $\Omega$	SMT resistor, 0603
R6, R20, R25	24 k $\Omega$	SMT resistor, 0603
R8	10 k $\Omega$	SMT resistor, 0603
R9, R14, R30	1 k $\Omega$	SMT resistor, 0603
R10, R11, R12, R13		1% 1 W SMT resistor, 2512
R18, R26	7.5 k $\Omega$	SMT resistor, 0603
R27	3.9 k $\Omega$	SMT resistor, 0603
R29	$\Omega$	5% 1W SMT resistor, 2512
TR1	200 k $\Omega$	SMT trimmer
TR2	500 $\Omega$	SMT trimmer
U1, U2	L6393D	Half-bridge gate driver, in SO14

Board description

EVAL6393FB

Figure 3. EVAL6393FB – layout (top layer)

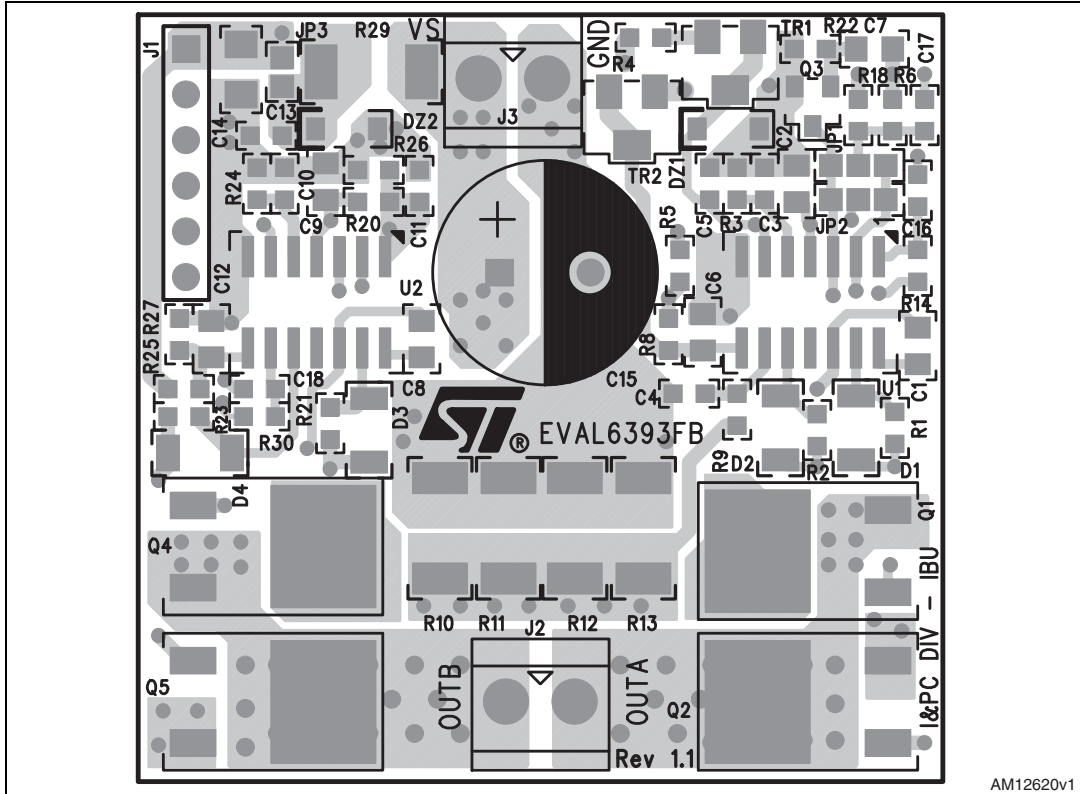
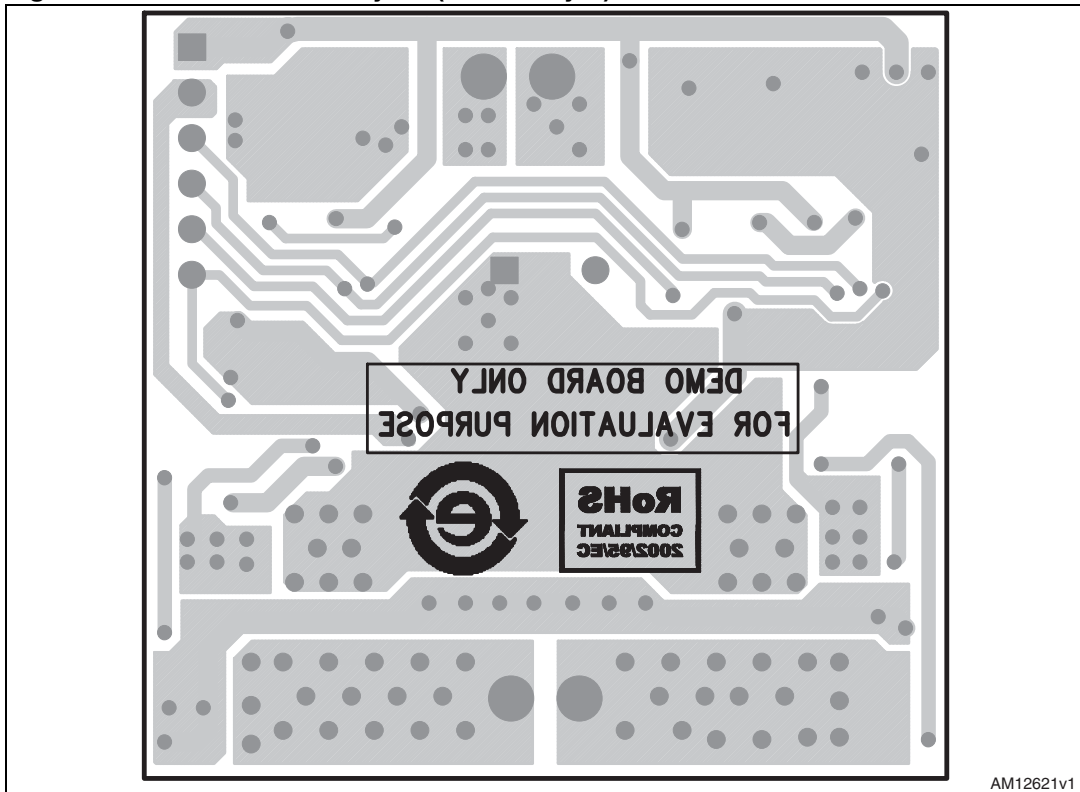

Figure 4. EVAL6393FB – layout (bottom layer)



**EVAL6393FB**

**Board description**

**Figure 5. EVAL6393FB – layout (component placement view)**

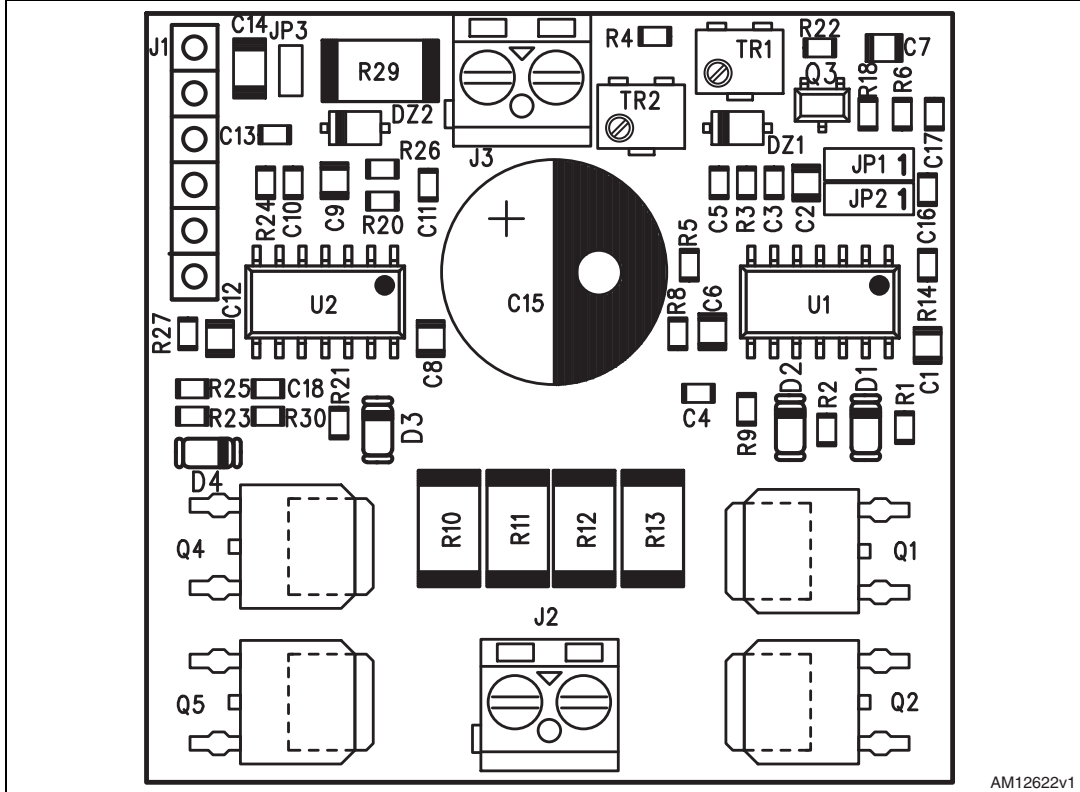



## 2 Revision history

Table 7. Document revision history

Date	Revision	Changes
23-Oct-2012	1	Initial release.

## EVAL6393FB

---

### **Please Read Carefully:**

Information in this document is provided solely in connection with ST products. STMicroelectronics NV and its subsidiaries ("ST") reserve the right to make changes, corrections, modifications or improvements, to this document, and the products and services described herein at any time, without notice.

All ST products are sold pursuant to ST's terms and conditions of sale.

Purchasers are solely responsible for the choice, selection and use of the ST products and services described herein, and ST assumes no liability whatsoever relating to the choice, selection or use of the ST products and services described herein.

No license, express or implied, by estoppel or otherwise, to any intellectual property rights is granted under this document. If any part of this document refers to any third party products or services it shall not be deemed a license grant by ST for the use of such third party products or services, or any intellectual property contained therein or considered as a warranty covering the use in any manner whatsoever of such third party products or services or any intellectual property contained therein.

**UNLESS OTHERWISE SET FORTH IN ST'S TERMS AND CONDITIONS OF SALE ST DISCLAIMS ANY EXPRESS OR IMPLIED WARRANTY WITH RESPECT TO THE USE AND/OR SALE OF ST PRODUCTS INCLUDING WITHOUT LIMITATION IMPLIED WARRANTIES OF MERCHANTABILITY, FITNESS FOR A PARTICULAR PURPOSE (AND THEIR EQUIVALENTS UNDER THE LAWS OF ANY JURISDICTION), OR INFRINGEMENT OF ANY PATENT, COPYRIGHT OR OTHER INTELLECTUAL PROPERTY RIGHT.**

**UNLESS EXPRESSLY APPROVED IN WRITING BY TWO AUTHORIZED ST REPRESENTATIVES, ST PRODUCTS ARE NOT RECOMMENDED, AUTHORIZED OR WARRANTED FOR USE IN MILITARY, AIR CRAFT, SPACE, LIFE SAVING, OR LIFE SUSTAINING APPLICATIONS, NOR IN PRODUCTS OR SYSTEMS WHERE FAILURE OR MALFUNCTION MAY RESULT IN PERSONAL INJURY, DEATH, OR SEVERE PROPERTY OR ENVIRONMENTAL DAMAGE. ST PRODUCTS WHICH ARE NOT SPECIFIED AS "AUTOMOTIVE GRADE" MAY ONLY BE USED IN AUTOMOTIVE APPLICATIONS AT USER'S OWN RISK.**

Resale of ST products with provisions different from the statements and/or technical features set forth in this document shall immediately void any warranty granted by ST for the ST product or service described herein and shall not create or extend in any manner whatsoever, any liability of ST.

ST and the ST logo are trademarks or registered trademarks of ST in various countries.

Information in this document supersedes and replaces all information previously supplied.

The ST logo is a registered trademark of STMicroelectronics. All other names are the property of their respective owners.

© 2012 STMicroelectronics - All rights reserved

STMicroelectronics group of companies

Australia - Belgium - Brazil - Canada - China - Czech Republic - Finland - France - Germany - Hong Kong - India - Israel - Italy - Japan - Malaysia - Malta - Morocco - Philippines - Singapore - Spain - Sweden - Switzerland - United Kingdom - United States of America

[www.st.com](http://www.st.com)