

Excellent Integrated System Limited

Stocking Distributor

Click to view price, real time Inventory, Delivery & Lifecycle Information:

[Molex Connector Corporation](#)
[0424920323](#)

For any questions, you can email us directly:
sales@integrated-circuit.com

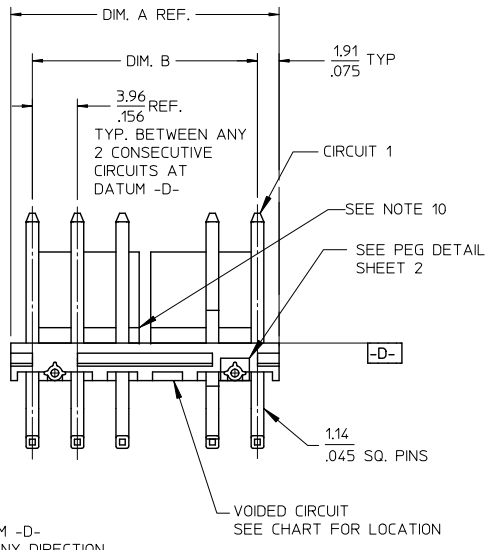
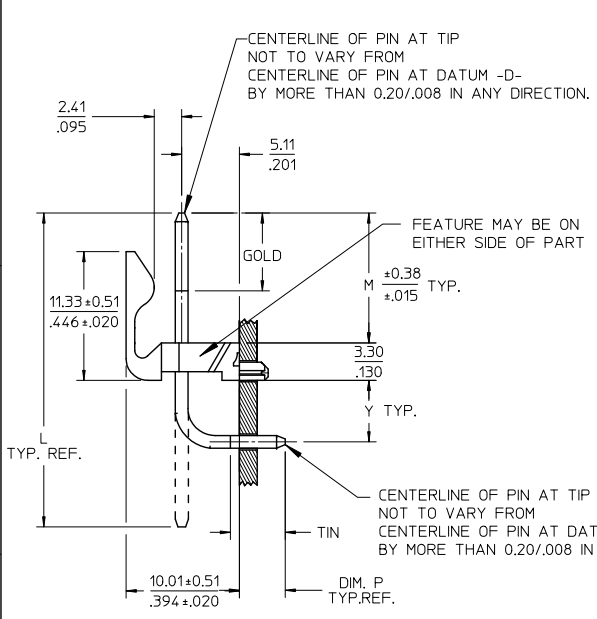

NO. OF CKTS.	DIM. A	DIM. B	SLOT LOC BETWEEN CKTS
2	7.77 .306	3.96 ± 0.05 .156 ± 0.02	NONE
3	11.73 .462	7.92 ± 0.08 .312 ± 0.03	NONE
4	15.70 .618	11.89 ± 0.08 .468 ± 0.03	NONE
5	19.66 .774	15.85 ± 0.10 .624 ± 0.04	NONE
6	23.62 .930	19.81 ± 0.10 .780 ± 0.04	3 & 4
7	27.58 1.086	23.77 ± 0.10 .936 ± 0.04	4 & 5
8	31.55 1.242	27.74 ± 0.13 1.092 ± 0.05	4 & 5
9	35.51 1.398	31.70 ± 0.13 1.248 ± 0.05	5 & 6
10	39.47 1.554	35.66 ± 0.13 1.404 ± 0.05	5 & 6
11	43.43 1.710	39.62 ± 0.15 1.560 ± 0.06	6 & 7
12	47.40 1.866	43.59 ± 0.15 1.716 ± 0.06	4 & 5 8 & 9

REMOVE PEG DIMS EC NO: UCP2012-2438 DRWN: J JAGUILAR 2012/02/02 CHKD: KKIPPER 2012/02/21 APPR: F SMITH 2012/02/24 DESCRIPTION REV	QUALITY SYMBOLS	GENERAL TOLERANCES (UNLESS SPECIFIED)	DIMENSION STYLE	SCALE	DESIGN UNITS	THIRD ANGLE PROJECTION
	∇=0 ∇=0 ∇=0	4 PLACES ± --- ± --- 3 PLACES ± --- ± .010 2 PLACES ± 0.25 ± .015 1 PLACE ± 0.38 ± --- ANGULAR ± 1/2°	MM/IN	2:1	INCH	
		DRAFT WHERE APPLICABLE MUST REMAIN WITHIN DIMENSIONS	DRAWN BY JSCHAFFER DATE 11-25-03	TITLE KK .156 HEADER ASSEMBLY FRICTION LOCK RT ANGLE WITH PEGS		
			CHECKED BY SAMIEC DATE 11-26-03	MOLEX INCORPORATED		
			APPROVED BY MARGULIS DATE 12-1-03	DOCUMENT NO. SD-42492-001 SHEET NO. 1 OF 7		

ib_frame_A_P_AM_T
Rev. F 2009/06/18

5	4	3	2	1
---	---	---	---	---

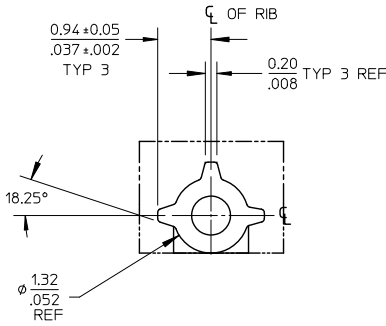

PEG DETAIL
SCALE 10:1

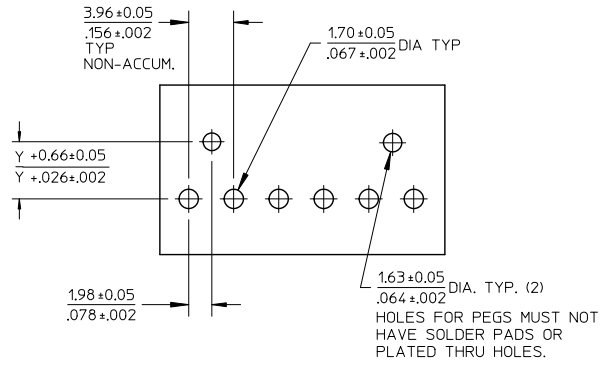

RECOMMENDED PC BOARD HOLE LAYOUT

NOTES:

1. MATERIAL: HEADER-POLYESTER, 94V-0, MOLDED NATURAL (WHITE)
PINS: BRASS
2. FINISHES: (154) OVERALL TIN 0.00254/.000100 MIN.
OVER 0.00127/.000050 MIN. NICKEL.
(197) OVERALL REFLOWED MATTE TIN: 0.00152/.000060 MIN.
OVER 0.00127/.000050 MIN. NICKEL OVERALL.
(208) SELECT GOLD 0.00038/.000015 MIN.
SELECT TIN 0.00254/.000100 MIN.
OVERALL NICKEL UNDERPLATE 0.00127/.000050 MIN.
(228) SELECT GOLD 0.00076/.000030 MIN.
SELECT TIN 0.00254/.000100 MIN.
OVERALL NICKEL UNDERPLATE 0.00127/.000050 MIN.
(241) SELECT GOLD: 0.00051/.000020 MIN.
SELECT TIN: 0.00254/.000100 MIN.
OVERALL NICKEL UNDERPLATE: 0.00127/.000050 MIN.
3. PRODUCT SPECIFICATION: SEE PS-08-50.
4. PACKAGING INFO: SEE TABLES.
5. SOLDERABILITY: PER SMES-152.
6. PIN PUSH OUT FORCE: PRIOR TO SOLDERING, A 3 LB MINIMUM FORCE (IN EITHER DIRECTION) SHALL BE REQUIRED TO PUSH THE PIN OUT OF THE HEADER.
7. PARTS ARE STACKABLE END TO END ON 3.96/.156 CENTERS.
8. FOR PART WITHOUT PEGS SEE 41792.
9. THIS PART CONFORMS TO CLASS B REQUIREMENTS OF COSMETIC SPECIFICATION PS-45499-002.
10. SLOTS ON BACKWALL ARE BETWEEN CIRCUITS. SEE CHART FOR LOCATION.

SEE SHEET 1 EC NO: UCP2012-2438 DRAWN: J JAGUILAR 2012/02/02 CHKD: MK PIPPER 2012/02/21 APPR: F SMITH 2012/02/24	QUALITY SYMBOLS ▽=0 ▽=0 ▽=0	GENERAL TOLERANCES (UNLESS SPECIFIED)		DIMENSION STYLE MM/IN		SCALE 1:1	DESIGN UNITS INCH	THIRD ANGLE PROJECTION		
		4 PLACES ± --- ± ---	3 PLACES ± --- ± .010	2 PLACES ± 0.25 ± .015	1 PLACE ± 0.38 ± ---	ANGULAR ± 1/2°	DRAWN BY JSCHAFFER	DATE 11-25-03	TITLE KK .156 HEADER ASSEMBLY FRICTION LOCK RT ANGLE WITH PEGS	
		DRAFT WHERE APPLICABLE MUST REMAIN WITHIN DIMENSIONS		SEE CHART		APPROVED BY MARGULIS		DATE 12-1-03	MATERIAL NO.	DOCUMENT NO. SD-42492-001
		SIZE A		THIS DRAWING CONTAINS INFORMATION THAT IS PROPRIETARY TO MOLEX INCORPORATED AND SHOULD NOT BE USED WITHOUT WRITTEN PERMISSION						

tb_frame_A_P_AM_T
Rev. F 2009/06/18

5

4

3

2

1