

Excellent Integrated System Limited

Stocking Distributor

Click to view price, real time Inventory, Delivery & Lifecycle Information:

[Molex Connector Corporation](#)
[0430450824](#)

For any questions, you can email us directly:

sales@integrated-circuit.com

13 12 11 10 9 8 7 6 5 4 3 2 1

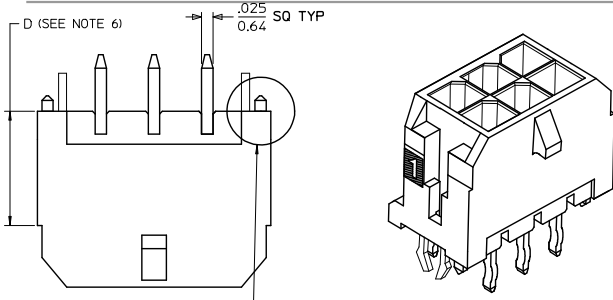

NOTE : (2) POLARIZATION PEGS ARE SHOWN. HOWEVER, ASSEMBLIES MAY BE MANUFACTURED WITH (1) PEG ONLY.

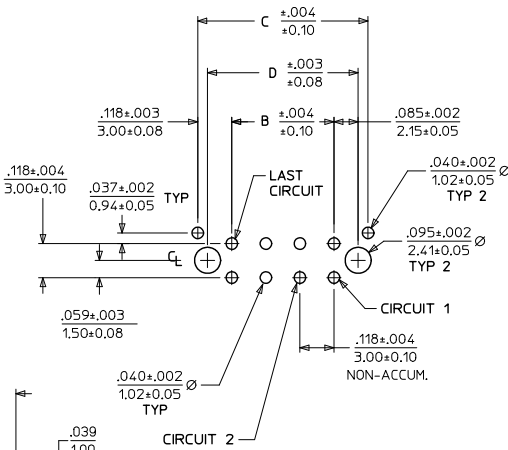
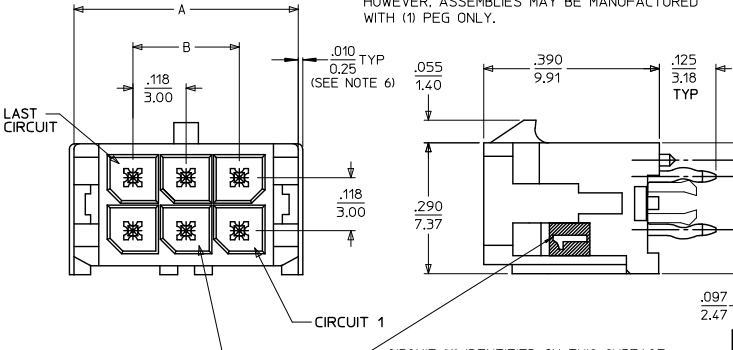

PCB LAYOUT: COMPONENT SIDE RECOMMEND PCB THICKNESS: .062/1/57

CKTS	A	B	C	D
02	.262	NA	.236	.169
04	.380	.118	.354	.287
	9.65	3.00	9.00	7.30
06	.498	.236	.472	.405
	12.65	6.00	12.00	10.30
08	.616	.354	.591	.524
	15.65	9.00	15.00	13.30
10	.734	.472	.709	.642
	18.65	12.00	18.00	16.30
12	.852	.591	.827	.760
	21.65	15.00	21.00	19.30
14	.970	.709	.945	.878
	24.65	18.00	24.00	22.30
16	1.088	.827	1.063	.996
	27.65	21.00	27.00	25.30
18	1.206	.945	1.181	1.114
	30.65	24.00	30.00	28.30
20	1.325	1.063	1.299	1.232
	33.65	27.00	33.00	31.30
22	1.443	1.181	1.417	1.350
	36.65	30.00	36.00	34.30
24	1.561	1.299	1.535	1.469
	39.65	33.00	39.00	37.30

NOTES:
CIRCUIT 1
CIRCUIT 2
CIRCUIT *1* IDENTIFIED ON THIS SURFACE (APPROX. LOCATION SHOWN FOR REF.)

- HOUSING MATERIAL: GLASS FILLED LIQUID CRYSTAL POLYMER, UL94V-0, COLOR: BLACK
TERMINAL MATERIAL: BRASS ALLOY
- FINISH: A = .000060/(0.00152) MIN. REFLOWED MATTE TIN OVER .000050/(0.00127) MIN. NICKEL PLATE. (FINISH IS BRIGHT IN APPEARANCE, THICKNESS AS APPLIED PRIOR TO REFLOW)
B = .000015/(0.00038) MIN. SELECT GOLD IN CONTACT AREA, .000100/(0.00254) MIN. SELECT MATTE TIN ON SOLDER TAILS, BOTH OVER .000050/(0.00127) MIN. NICKEL PLATE.
C = .000030/(0.00076) MIN. SELECT GOLD IN CONTACT AREA, .000100/(0.00254) MIN. SELECT MATTE TIN ON SOLDER TAILS, BOTH OVER .000050/(0.00127) MIN. NICKEL PLATE.
D = .000100/(0.00254) MIN. MATTE TIN OVER .000050/(0.00127) MIN. NICKEL PLATE.
- PRODUCT SPECIFICATION: PS-43045
- TRAY PACKAGED: SEE MOLEX DRAWING PK-70873-0314
- MATES WITH MICRO FIT (3.0) RECEPTACLE SERIES 43025
- CIRCUIT SIZES 2-6: 'D' IS .265/6.74 FOR .010/0.25 STEP
CIRCUIT SIZES 8-24: 'D' IS .063/1.60 FOR .010/0.25 STEP.
- THIS PART CONFORMS TO CLASS B REQUIREMENTS OF COSMETIC SPECIFICATION PS-45499-002.

CKTS	FINISH A	FINISH B	FINISH C	FINISH D
02	43045-0224	43045-0225	43045-0226	43045-0304
04	43045-0424	43045-0425	43045-0426	43045-0504
06	43045-0624	43045-0625	43045-0626	43045-0704
08	43045-0824	43045-0825	43045-0826	43045-0904
10	43045-1024	43045-1025	43045-1026	43045-1104
12	43045-1224	43045-1225	43045-1226	43045-1304
14	43045-1424	43045-1425	43045-1426	43045-1504
16	43045-1624	43045-1625	43045-1626	43045-1704
18	43045-1824	43045-1825	43045-1826	43045-1904
20	43045-2024	43045-2025	43045-2026	43045-2104
22	43045-2224	43045-2225	43045-2226	43045-2304
24	43045-2424	43045-2425	43045-2426	43045-2504

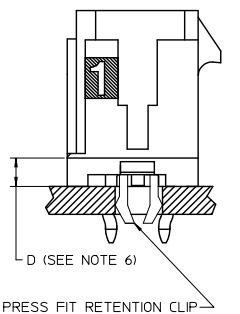

REVISE FINISH A DEC NO: UCP/2016-04/24 2015/08/20 DRW: JPOX CHK: D3050K APPR: SMITH 2015/11/19	QUALITY SYMBOLS □=0 ▽=0 ○=0	GENERAL TOLERANCES (UNLESS SPECIFIED) mm INCH	DIMENSION STYLE IN/MM	SCALE ---	DESIGN UNITS METRIC	THIRD ANGLE PROJECTION
		4 PLACES ± --- ± --- 3 PLACES ± --- ± .010 2 PLACES ± 0.25 ± .014 1 PLACE ± 0.36 ± --- 0 PLACE ± ±	DRAWN BY DATE SAMIEC 2000/03/15 CHECKED BY DATE MUELLER 2000/03/15 APPROVED BY DATE EDGLEY 2000/03/15	MATERIAL NO. SEE CHART	DOCUMENT NO. SD-43045-009	SHEET NO. 1 OF 1
		ANGLULAR ±1/2° DRAFT WHERE APPLICABLE MUST REMAIN WITHIN DIMENSIONS				

THIS DRAWING CONTAINS INFORMATION THAT IS PROPRIETARY TO MOLEX INCORPORATED AND SHOULD NOT BE USED WITHOUT WRITTEN PERMISSION

12 11 10 9 8 7 6 5 4 3 2 1