

## Excellent Integrated System Limited

Stocking Distributor

Click to view price, real time Inventory, Delivery & Lifecycle Information:

[TE Connectivity Measurement Specialties  
3052-002-P](#)

For any questions, you can email us directly:

[sales@integrated-circuit.com](mailto:sales@integrated-circuit.com)

# Model 3052



**PC Board Mountable Accelerometer**  
**Millivolt Output**  
**Integral Temperature Compensation**

- ▶ Vibration/Shock Monitoring
- ▶ Modal Analysis
- ▶ Motion Control
- ▶ Crash Testing
- ▶ Aerospace

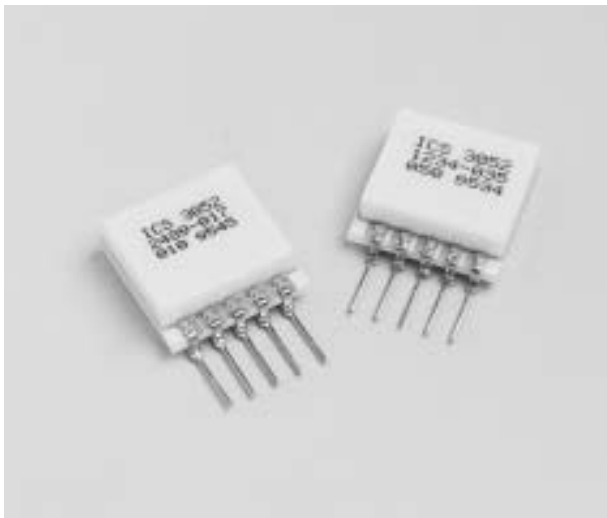

## DESCRIPTION

The Model 3052 is a piezoresistive silicon accelerometer with integral temperature compensation. It is packaged on a ceramic substrate with an epoxy sealed ceramic cover and is designed for adhesive mounting.

The accelerometer consists of a micro machined silicon mass suspended by multiple beams from a silicon frame. Piezoresistors located in the beams change their resistance as the motion of the suspended mass changes the strain in the beams. Silicon caps on the top and bottom of the device are added to provide over-range stops. This design provides for a very low profile, high shock resistance, durability and built-in damping over a wide usable bandwidth. Each sensor is individually serialized.

For an accelerometer with a mounting bracket which can be used to bolt the sensor to the mounting location see the Model 3058. For uncompensated accelerometers, please refer to the Models 3022 and 3028.

## FEATURES

- ▶ Adhesive Mount
- ▶  $\pm 0.5\%$  Non-linearity (Typical)
- ▶  $\pm 1.0\%$  Temperature Performance (Typical)
- ▶ Dc Response
- ▶ Built-in Damping
- ▶ Built-in Overrange Stops
- ▶ Low Power

## STANDARD RANGES

Range	g	Range	g
$\pm 2$	●	$\pm 20$	●
$\pm 5$	●	$\pm 50$	●
$\pm 10$	●	$\pm 100$	●

PC Board Mountable Accelerometer

Model 3052

CALIBRATION DATA

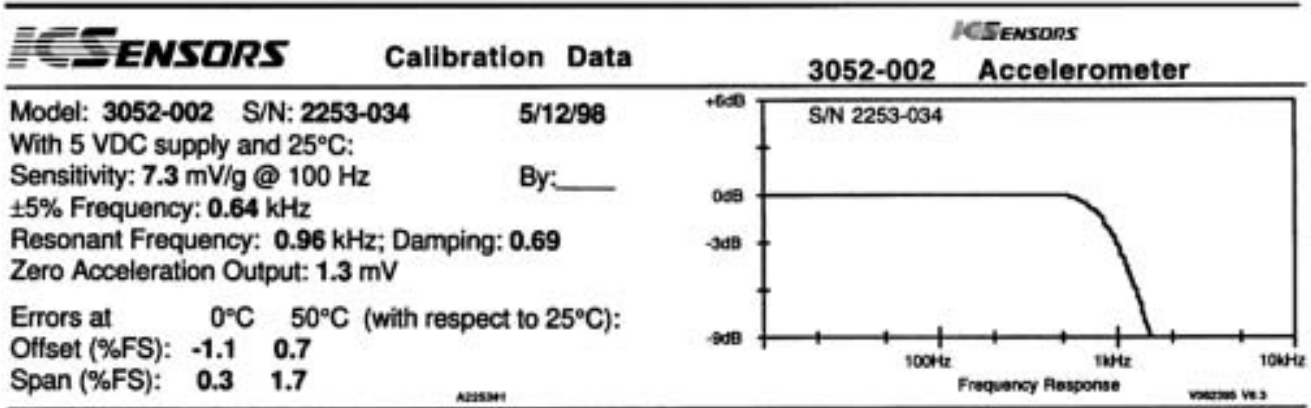
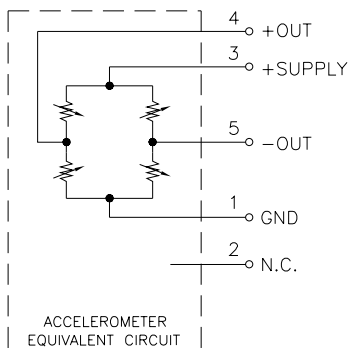
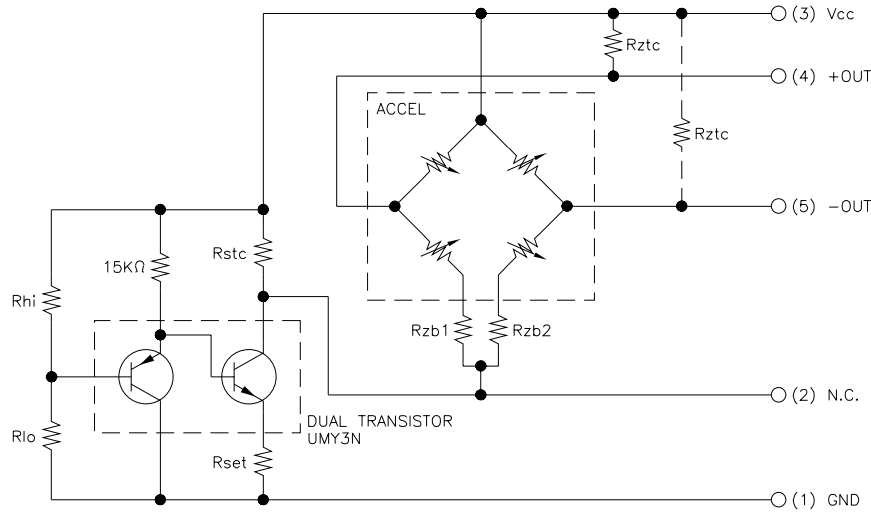

Figure 1. Calibration Data Sheet

A calibration data sheet similar to the sample shown above is included with each unit. The calibration sheet provides the measured test and calibration data for the sensor.

CONNECTIONS



PIN NUMBER	FUNCTION
1	GROUND
2	ICS USE ONLY
3	SUPPLY
4	-OUTPUT
5	+OUTPUT

RESISTOR	FUNCTION	OHMS
R1	Rzb	10-50
R2	Rset	250-350
R3	Rlo	800-1250
R5	Rhi	7.5K-50K
R6	Rstc	3K-99K
R7	Rztc	0.15M-4M

## Model 3052

## PC Board Mountable Accelerometer

### PERFORMANCE SPECIFICATIONS

Supply Voltage: 5.0 VDC

Ambient Temperature: 25°C (Unless otherwise specified)

PARAMETERS	RANGE			UNITS	NOTES
	±2g	±5g	±10g		
Frequency Response [MIN]	0-250	0-300	0-400	Hz	1, 2
Mounted Resonant Frequency [MIN]	700	800	1000	Hz	1
Sensitivity (MIN/MAX)	6.0/9.0	2.4/3.6	1.2/1.8	mV/g	1, 3

PARAMETERS	RANGE			UNITS	NOTES
	±20g	±50g	±100g		
Frequency Response [MIN]	0-600	0-1000	0-1500	Hz	1, 2
Mounted Resonant Frequency [MIN]	1500	2000	3000	Hz	1, 4
Sensitivity (MIN/MAX)	0.6/0.9	0.24/0.36	0.12/0.18	mV/g	1, 3

PARAMETERS	MIN	TYP	MAX	UNITS	NOTES
Zero Acceleration Output		1	2	±mV	1
Damping Ratio	0.4	0.7	0.9		1, 4
Non-linearity		0.5	1	±% Span	5
Transverse Sensitivity		1	3	±% Span	
Output Resistance	2.5	3.5	6.5	KΩ	
Temperature error - Sensitivity		1.0	2.0	±% Span	1, 6
Temperature error - Zero		1.0	2.0	±% Span	1, 6
Supply Voltage		5.0	10.0	VDC	
Current		1.5		mA	
Output Noise		1.0		μV p-p	
Output Load Resistance	5			MΩ	7
Acceleration Limits (Any Direction)		20X		Rated	8
Operating Temperature	-40°C to +125°C				
Compensated Temperature Range	0°C to +50°C				
Storage Temperature	-55°C to +150°C				
Weight	6.5 Grams				

#### Notes

- Actual test data for this parameter is included on the calibration sheet included with each sensor. A sample of this calibration sheet is shown as Figure 1.
- The useful frequency range is defined as the range of frequencies over which the device sensitivity is within ±5% of the DC value.
- Positive voltage change for positive acceleration; negative voltage change for negative acceleration.
- For sensors having resonant frequency greater than 5 kHz, the calibration data sheet will indicate ">5 kHz". In addition, the damping ratio will indicate N/A.
- Best Fit Straight Line. For full scale ranges of 10g or less, the maximum non-linearity is ±2%.
- Compensated temperature range: 0°C to +50°C in reference to 25°C.
- Prevents increase of TC-Span and sensitivity decrease due to output loading.
- 400g for ±2g, ±5g and ±10g versions, 20X or 2000g, whichever is lower, for other versions.

PC Board Mountable Accelerometer

Model 3052

DIMENSIONS

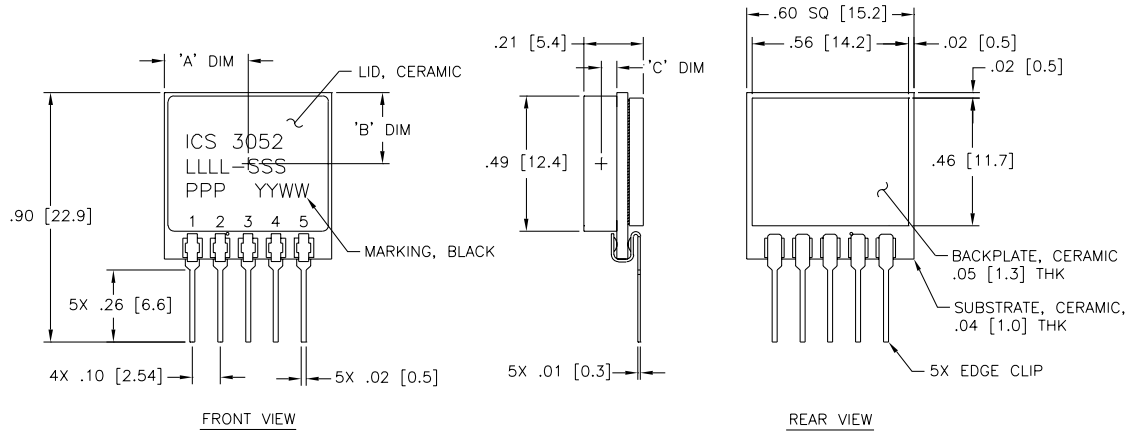

ALL DIMENSIONS ARE IN INCHES [mm]

LTR	2 - 10 g	20 - 500 g
"A" DIM	0.300 ± 0.005 [7.62 ± 0.13]	0.265 ± 0.005 [6.73 ± 0.13]
"B" DIM	0.250 ± 0.005 [6.35 ± 0.13]	0.240 ± 0.005 [6.10 ± 0.13]
"C" DIM	0.032 ± 0.004 [0.81 ± 0.10]	0.032 ± 0.004 [0.81 ± 0.10]

ORDERING INFORMATION

3052 - 005 - P

