

Excellent Integrated System Limited

Stocking Distributor

Click to view price, real time Inventory, Delivery & Lifecycle Information:

[Phoenix Contact](#)
[2800567](#)

For any questions, you can email us directly:

sales@integrated-circuit.com



Extract from the online catalog

MBKKB 2,5-DIO/O-U

Order No.: 2800567

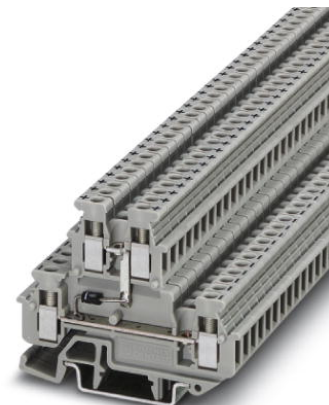

<http://eshop.phoenixcontact.de/phoenix/treeViewClick.do?UID=2800567>

Feed-through modular terminal block, Connection type: Screw connection, Cross section: 0.2 mm² - 4 mm², AWG: 24 - 12, Nominal current: 24 A, Nominal voltage: 500 V, Length: 62 mm, Width: 5.2 mm, Color: gray, Assembly: NS 35/7,5, NS 35/15, NS 32

Commercial data

EAN	4017918074258
Pack	50 pcs.
Customs tariff	85369010
Weight/Piece	0.01215 KG
Catalog page information	Page 441 (CL-2009)

Product notes

WEEE/RoHS-compliant since:
07/01/2006



<http://www.download.phoenixcontact.com>
Please note that the data given here has been taken from the online catalog. For comprehensive information and data, please refer to the user documentation. The General Terms and Conditions of Use apply to Internet downloads.

Technical data

General

Number of levels	2
Number of connections	4
Color	gray

MBKKB 2,5-DIO/O-U Order No.: 2800567

<http://eshop.phoenixcontact.de/phoenix/treeViewClick.do?UID=2800567>

Insulating material	PA
Inflammability class acc. to UL 94	V2

Dimensions

Width	5.2 mm
Length	62 mm
Height NS 35/7,5	48 mm
Height NS 35/15	55.5 mm

Technical data

Maximum load current	24 A (with 2.5 mm ² conductor cross section)
Rated surge voltage	6 kV
Pollution degree	3
Surge voltage category	III
Insulating material group	I
Nominal current I _N	24 A
Nominal voltage U _N	500 V (Data is based on the dielectric strength of adjacent terminal blocks or of the DINg rail.)

Connection data

Conductor cross section solid min.	0.2 mm ²
Conductor cross section solid max.	4 mm ²
Conductor cross section stranded min.	0.2 mm ²
Conductor cross section stranded max.	2.5 mm ²
Conductor cross section AWG/kcmil min.	24
Conductor cross section AWG/kcmil max	12
Conductor cross section stranded, with ferrule without plastic sleeve min.	0.25 mm ²
Conductor cross section stranded, with ferrule without plastic sleeve max.	2.5 mm ²
Conductor cross section stranded, with ferrule with plastic sleeve min.	0.25 mm ²
Conductor cross section stranded, with ferrule with plastic sleeve max.	2.5 mm ²
2 conductors with same cross section, solid min.	0.2 mm ²
2 conductors with same cross section, solid max.	1 mm ²
2 conductors with same cross section, stranded min.	0.2 mm ²

MBKKB 2,5-DIO/O-U Order No.: 2800567

<http://eshop.phoenixcontact.de/phoenix/treeViewClick.do?UID=2800567>

2 conductors with same cross section, stranded max.	1.5 mm ²
2 conductors with same cross section, stranded, ferrules without plastic sleeve, min.	0.25 mm ²
2 conductors with same cross section, stranded, ferrules without plastic sleeve, max.	1.5 mm ²
2 conductors with same cross section, stranded, TWIN ferrules with plastic sleeve, min.	0.5 mm ²
2 conductors with same cross section, stranded, TWIN ferrules with plastic sleeve, max.	1.5 mm ²
Cross-section with insertion bridge, solid max.	2.5 mm ²
Cross-section with insertion bridge, stranded max.	2.5 mm ²
Type of connection	Screw connection
Stripping length	7 mm
Internal cylindrical gage	A3
Screw thread	M3
Tightening torque, min	0.5 Nm
Tightening torque max	0.6 Nm

Certificates / Approvals

Certification

GOST

Accessories

Item	Designation	Description
Assembly		
3022218	CLIPFIX 35	Snap-on end bracket, for 35 mm NS 35/7.5 or NS 35/15 DIN rail, can be fitted with Zack strip ZB 8 and ZB 8/27, terminal strip marker KLM 2 and KLM, width: 9.5 mm, color: gray
1413052	D-MBKKB 2,5	End cover, Length: 62 mm, Width: 2.5 mm, Color: gray
1413065	DP-MBKKB 2,5	Spacer plate, Length: 62 mm, Width: 2.5 mm, Color: gray
1401637	E/MBK	End bracket, width: 6.2 mm, color: gray
1401763	NS 15 AL PERF 2000MM	DIN rail, material: Aluminum, perforated, height 5.5 mm, width 15 mm, length: 2 m
1401682	NS 15 PERF 2000MM	DIN rail, material: steel, perforated, height 5.5 mm, width 15 mm, length: 2 m

MBKKB 2,5-DIO/O-U Order No.: 2800567

<http://eshop.phoenixcontact.de/phoenix/treeViewClick.do?UID=2800567>

1401695	NS 15 UNPERF 2000MM	DIN rail, material: Steel, unperforated, height 5.5 mm, width 15 mm, length: 2 m
0801762	NS 35/ 7,5 CU UNPERF 2000MM	DIN rail, material: Copper, unperforated, height 7.5 mm, width 35 mm, length: 2 m
0801733	NS 35/ 7,5 PERF 2000MM	DIN rail, material: Steel, galvanized and passivated with a thick layer, perforated, height 7.5 mm, width 35 mm, length: 2 m
0801681	NS 35/ 7,5 UNPERF 2000MM	DIN rail, material: Steel, unperforated, height 7.5 mm, width 35 mm, length: 2 m
1201756	NS 35/15 AL UNPERF 2000MM	DIN rail, deep-drawn, high profile, unperforated, 1.5 mm thick, material: Aluminum, height 15 mm, width 35 mm, length 2 m
1201895	NS 35/15 CU UNPERF 2000MM	DIN rail, material: Copper, unperforated, 1.5 mm thick, height 15 mm, width 35 mm, length: 2 m
1201730	NS 35/15 PERF 2000MM	DIN rail, material: Steel, perforated, height 15 mm, width 35 mm, length: 2 m
1201714	NS 35/15 UNPERF 2000MM	DIN rail, material: Steel, unperforated, height 15 mm, width 35 mm, length: 2 m
1201798	NS 35/15-2,3 UNPERF 2000MM	DIN rail, material: Steel, unperforated, 2.3 mm thick, height 15 mm, width 35 mm, length: 2 m

Bridges

3000175	FBRNI 2-5 N	Cross connector/bridge, Number of positions: 2, Color: silver
3000162	FBRNI 3-5 N	Cross connector/bridge, Number of positions: 3, Color: silver
3000159	FBRNI 4-5 N	Cross connector/bridge, Number of positions: 4, Color: silver
2770639	FBRNI 10-5 N	Cross connector/bridge, Number of positions: 10, Color: silver

Marking

1007219	SBS 5:UNBEDRUCKT	Marker cards for modular terminal blocks, color: white
1050295	ZB 5:SO/CMS	Zack strip, 10-section, divisible, special printing, marking according to customer requirements

Tools

1205053	SZS 0,6X3,5	Screwdriver, bladed, matches all screw terminal blocks up to 4.0 mm ² connection cross section, blade: 0.6 x 3.5 mm, without VDE approval
---------	-------------	--

MBKKB 2,5-DIO/O-U Order No.: 2800567

<http://eshop.phoenixcontact.de/phoenix/treeViewClick.do?UID=2800567>

Diagrams/Drawings

Circuit diagram

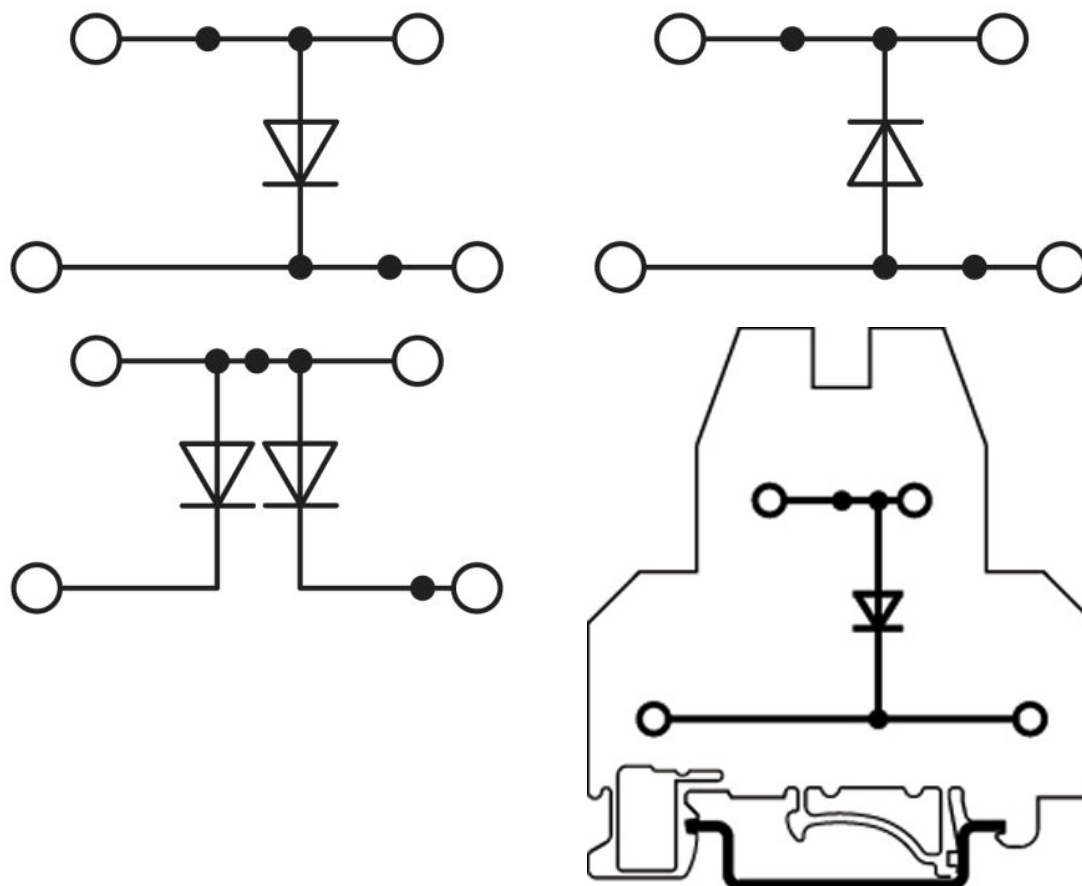

MBKKB 2,5-DIO/O-U Order No.: 2800567

<http://eshop.phoenixcontact.de/phoenix/treeViewClick.do?UID=2800567>

Address

PHOENIX CONTACT Inc., USA
586 Fulling Mill Road
Middletown, PA 17057, USA
Phone (800) 888-7388
Fax (717) 944-1625
<http://www.phoenixcon.com>



© 2010 Phoenix Contact
Technical modifications reserved;