



**Distributor of Abracon Corporation: Excellent Integrated System Limited**  
Datasheet of ABS06L-32.768KHZ-T - Crystal 32.7680kHz 20ppm 12.5pF 100 kOhm -40°C -  
85°C Surface Mount 2-SMD

Contact us: [sales@integrated-circuit.com](mailto:sales@integrated-circuit.com) Website: [www.integrated-circuit.com](http://www.integrated-circuit.com)

---

## Excellent Integrated System Limited

Stocking Distributor

Click to view price, real time Inventory, Delivery & Lifecycle Information:

[Abracon Corporation](#)  
[ABS06L-32.768KHZ-T](#)

For any questions, you can email us directly:

[sales@integrated-circuit.com](mailto:sales@integrated-circuit.com)

# 32.768kHz SMD LOW PROFILE CRYSTAL



2.0 x 1.2 x 0.38mm

**ABS06L**

**Moisture Sensitivity Level (MSL) – This product is Hermetically Sealed and not Moisture Sensitive - MSL = N/A: Not Applicable**

### FEATURES:

- Lowest height kHz package for 32.768kHz Crystals
- 0.38mm height ideal for high density circuit boards
- Ceramic package offers excellent environmental & heat resistance
- Extended temperature -40°C to +85°C for industrial applications

### APPLICATIONS:

- Smart Display Credit Cards
- Wide range in communication & measuring equipment
- Commercial & Industrial applications
- Wireless communications
- PDA and Palm Pilots
- Credit Cards with Security Technology

### STANDARD SPECIFICATIONS:

Parameters	Minimum	Typical	Maximum	Units	Notes
Frequency	32.768			kHz	
Operation Mode	Flexural Mode (Tuning Fork)				
Operating Temperature	-40		+85	°C	
Storage Temperature	-55		+125	°C	
Frequency Tolerance @+25°C	-20		+20	ppm	See options
Temperature Coefficient	-0.04	-0.03	-0.02	ppm/T <sup>2</sup>	
Turn-over temperature	+20	+25	+30	°C	
Equivalent series resistance (ESR)			100	kΩ	
Load capacitance	12.5			pF	See options
Drive Level		0.1	0.5	μW	
Aging (@ 25°C)	-3		+3	ppm	First year
Insulation Resistance	500			MΩ	@ DC 100±15V

### OPTIONS AND PART IDENTIFICATION:

(Left blank if standard)

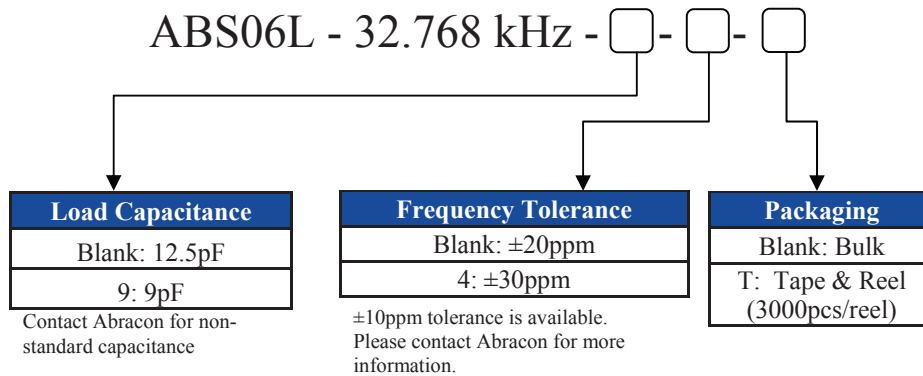

# 32.768kHz SMD LOW PROFILE CRYSTAL



2.0 x 1.2 x 0.38mm

ABS06L

RoHS/RoHS II Compliant

## OUTLINE DRAWING:

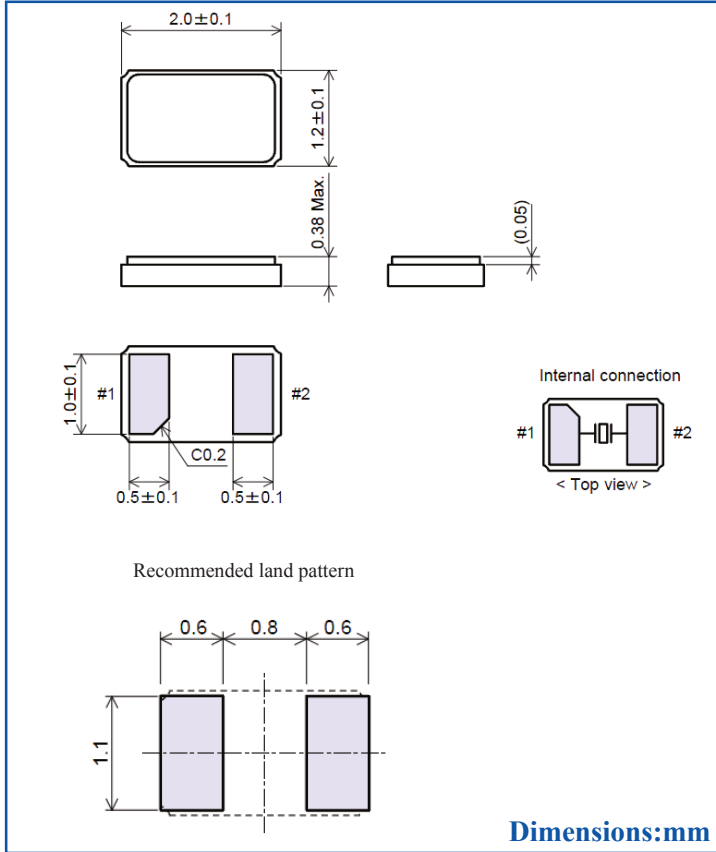

## TAPE & REEL:

T= Tape and reel (3,000pcs/reel)

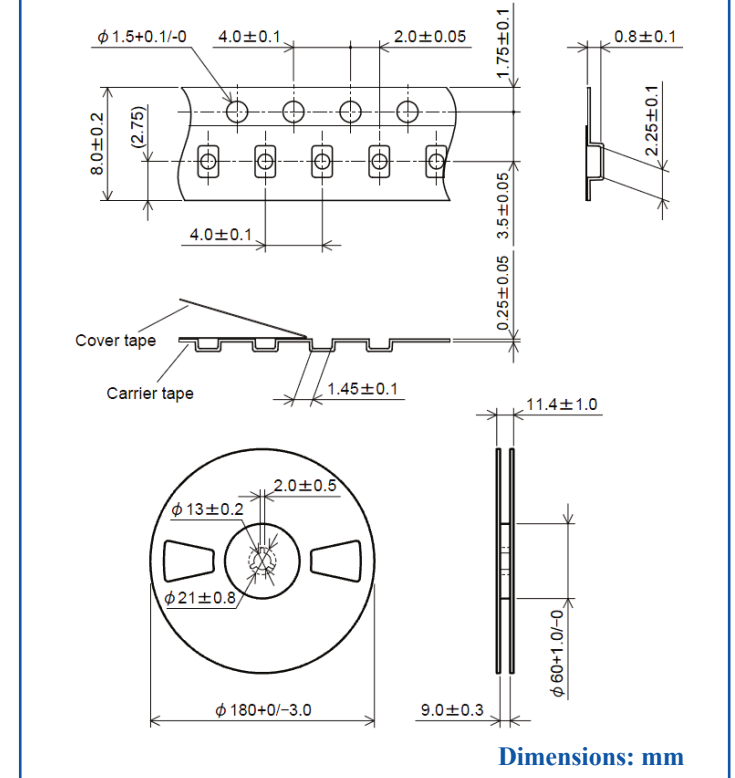

## REFLOW PROFILE:

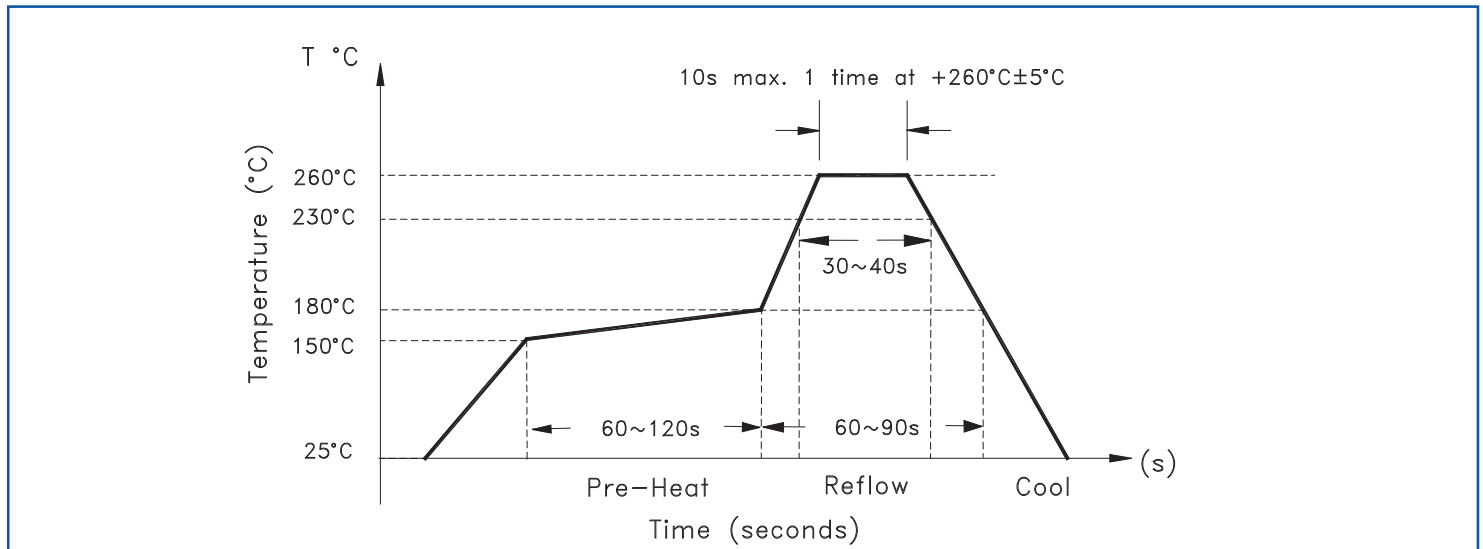

Need a test socket for the ABS06 Series? To view compatible **PRECISION TEST & BURN-IN SOCKETS** for these parts, [click here](#). P/N AXS-2012-02-04

**ATTENTION:** Abracon Corporation's products are COTS – Commercial-Off-The-Shelf products; suitable for Commercial, Industrial and, where designated, Automotive Applications. Abracon's products are not specifically designed for Military, Aviation, Aerospace, Life-dependant Medical applications or any application requiring high reliability where component failure could result in loss of life and/or property. For applications requiring high reliability and/or presenting an extreme operating environment, written consent and authorization from Abracon Corporation is required. Please contact Abracon Corporation for more information.