

## Excellent Integrated System Limited

Stocking Distributor

Click to view price, real time Inventory, Delivery & Lifecycle Information:

[Vishay Semiconductor/Diodes Division](#)  
[70EPF04](#)

For any questions, you can email us directly:

[sales@integrated-circuit.com](mailto:sales@integrated-circuit.com)

# International **IOR** Rectifier

# QUIETIR Series 70EPF..

## FAST SOFT RECOVERY RECTIFIER DIODE

	$V_F < 1.33V @ 70A$ $t_{rr} = 70ns$ $V_{RRM} 200/600V$
---	--

### Major Ratings and Characteristics

Characteristics	70EPF..	Units
$I_{F(AV)}$ 180° Sin. Conduction @ $T_C = 97^\circ C$	70	A
$V_{RRM}$ range	200/600	V
$I_{F(RMS)}$	135	A
$V_F @ 70A, T_J = 25^\circ C$	1.33	V
$t_{rr} @ 1A, -100A/\mu s$	70	ns
$T_J$ range	-40 to 150	°C

### Description/Features



The 70EPF.. fast soft recovery **QUIETIR** rectifier series has been optimized for combined short reverse recovery time and low forward voltage drop.

The glass passivation ensures stable reliable operation in the most severe temperature and power cycling conditions. Available in the new **PowIRtab™** package, this new series is suitable for a large range of applications combining excellent die to footprint ratio and sturdiness connectivity for use in high current environments.

Typical applications are both:

- Output rectification and freewheeling in inverters, choppers and converters
- Input rectifications where severe restrictions on conducted EMI should be met.

### Case Styles

<p>70EPF..</p> 	<p>70EPF..J</p> 
--	--

(\*) for higher voltage up to 1600V contact factory

70EPF.. **QUIETIR** Series

Bulletin I2154 rev. C 12/02

International  
**IR** Rectifier

**Voltage Ratings**

Part Number	$V_{RRM}$ , maximum peak reverse voltage V	$V_{RSM}$ , maximum non repetitive peak reverse voltage V	$I_{RRM}$ 150°C mA
70EPF02	200	300	13
70EPF04	400	500	
70EPF06	600	700	

**Absolute Maximum Ratings**

Parameters	70EPF..	Units	Conditions
$I_{F(AV)}$ Max. Average Forward Current	70	A	@ $T_C = 97^\circ\text{C}$ , 180° conduction half sine wave
$I_{FSM}$ Max. Peak One Cycle Non-Repetitive Surge Current	850	A	10ms Sine pulse, rated $V_{RRM}$ applied
	1000		10ms Sine pulse, no voltage reapplied
$I^2t$ Max. $I^2t$ for fusing	3600	$A^2s$	10ms Sine pulse, rated $V_{RRM}$ applied
	5100		10ms Sine pulse, no voltage reapplied
$I^2\sqrt{t}$ Max. $I^2\sqrt{t}$ for fusing	51000	$A^2\sqrt{s}$	10ms, no voltage reapplied

**Electrical Specifications**

Parameters	70EPF..	Units	Conditions
$V_{FM}$ Max. Forward Voltage Drop	1.33	V	@ 70A, $T_J = 25^\circ\text{C}$
$r_t$ Forward slope resistance	3.65	mΩ	$T_J = 150^\circ\text{C}$
$V_{F(TO)}$ Threshold voltage	0.918	V	
$I_{RM}$ Max. Reverse Leakage Current	0.1	mA	$T_J = 25^\circ\text{C}$
	13		$T_J = 150^\circ\text{C}$

$V_R = \text{rated } V_{RRM}$

**Recovery Characteristics**

Parameters	70EPF..	Units	Conditions
$t_{rr}$ Reverse Recovery Time	200	ns	$I_F @ 70\text{Apk}$
$I_{rr}$ Reverse Recovery Current	4	A	@ 25A/μs
$Q_{rr}$ Reverse Recovery Charge	0.67	μC	@ 25°C
S Snap Factor	0.5		

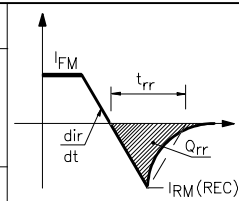

**Thermal-Mechanical Specifications**

Parameters	70EPF..	Units	Conditions
T <sub>J</sub> Max. Junction Temperature Range	-40 to 150	°C	
T <sub>stg</sub> Max. Storage Temperature Range	-40 to 150	°C	
R <sub>thJC</sub> Max. Thermal Resistance Junction to Case	0.35	°C/W	DC operation
R <sub>thJA</sub> Max. Thermal Resistance Junction to Ambient	40	°C/W	
R <sub>thCS</sub> Typical Thermal Resistance, Case to Heatsink	0.2	°C/W	Mounting surface, smooth and greased
wt Approximate Weight	6(0.21)	g(oz.)	
T Mounting Torque	Min.	6(5)	Kg-cm (lbf-in)
	Max.	12(10)	
Case Style	<i>PowIRtab</i> <sup>TM</sup>		

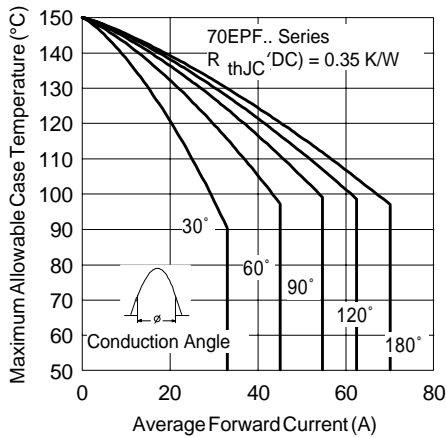

Fig. 1 - Current Rating Characteristics

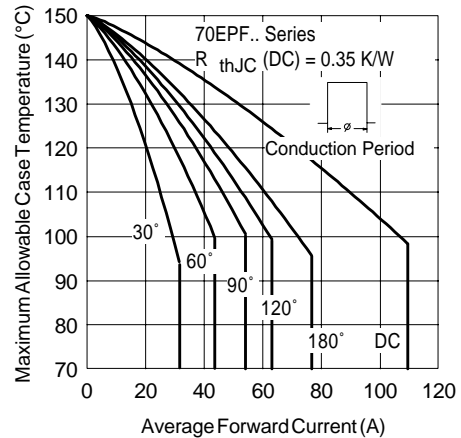

Fig. 2 - Current Rating Characteristics

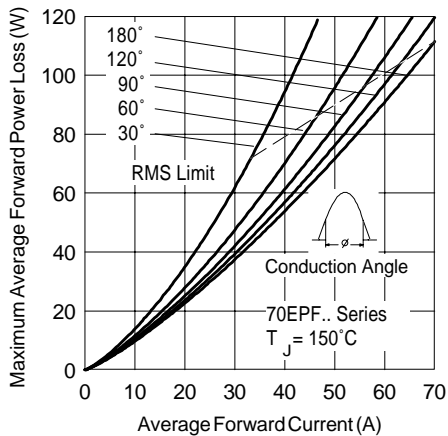

Fig. 3 - Forward Power Loss Characteristics

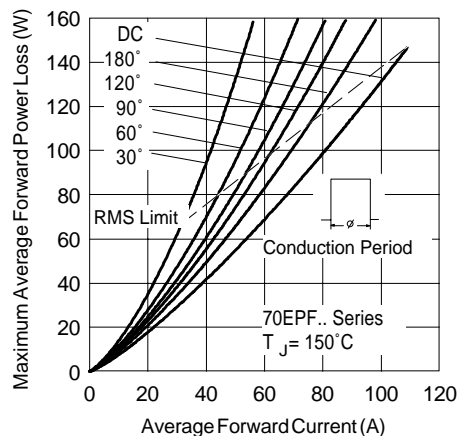

Fig. 4 - Forward Power Loss Characteristics

70EPF.. **QUIETIR** Series

Bulletin I2154 rev. C 12/02

International  
**IRF** Rectifier

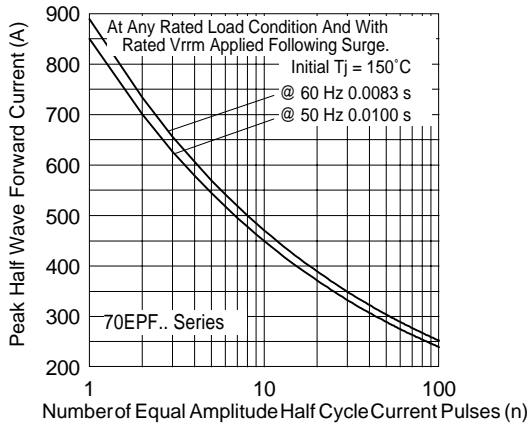

Fig.5-Maximum Non-Repetitive Surge Current

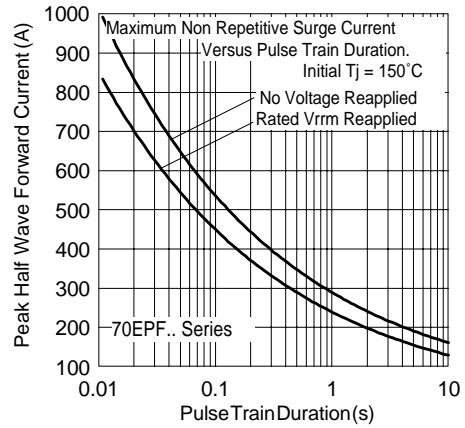

Fig.6-Maximum Non-Repetitive Surge Current

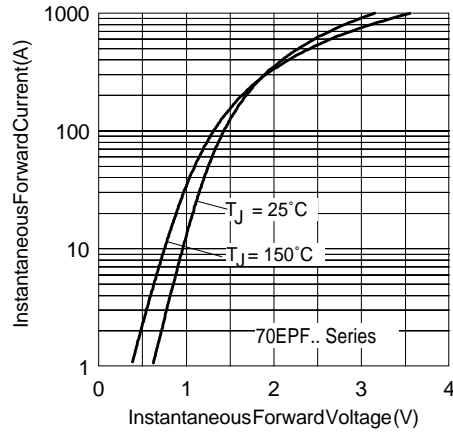

Fig.7-Forward Voltage Drop Characteristics

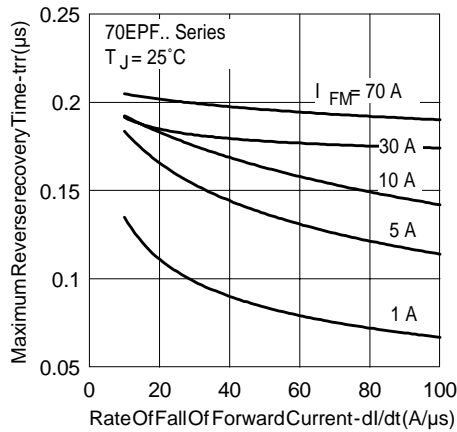

Fig.8-Recovery Time Characteristics,  $T_J = 25^\circ\text{C}$

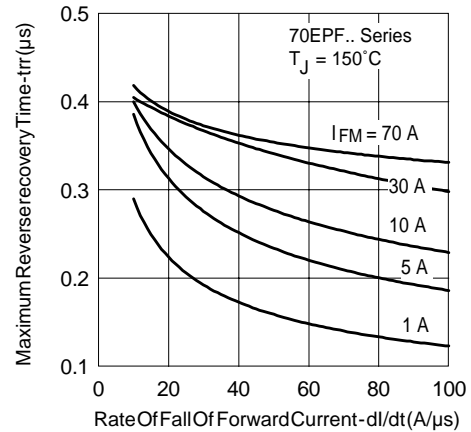

Fig.9-Recovery Time Characteristics,  $T_J = 150^\circ\text{C}$

International  
**IOR** Rectifier

70EPF.. **QUIETIR** Series

Bulletin I2154 rev. C 12/02

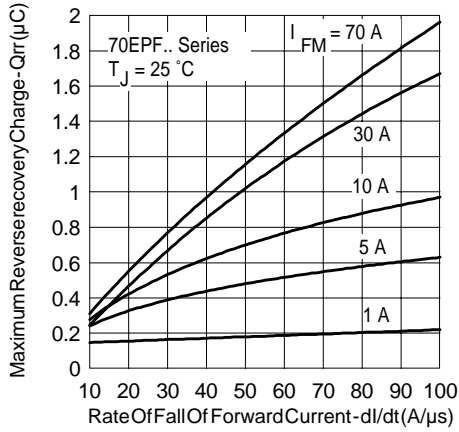

Fig. 10 - Recovery Charge Characteristics,  $T_J = 25^\circ\text{C}$

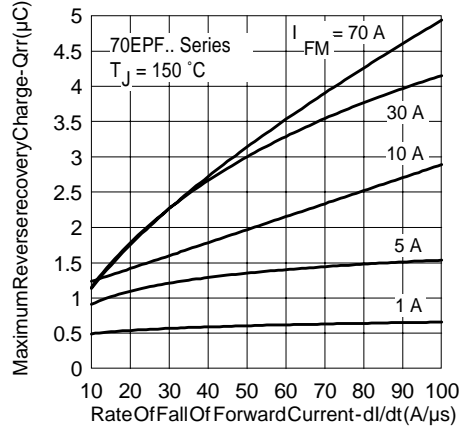

Fig. 11 - Recovery Charge Characteristics,  $T_J = 150^\circ\text{C}$

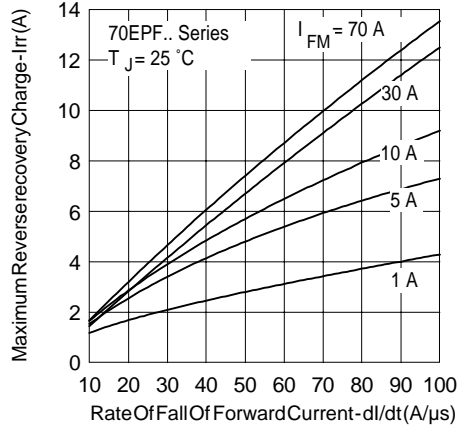

Fig. 12 - Recovery Current Characteristics,  $T_J = 25^\circ\text{C}$

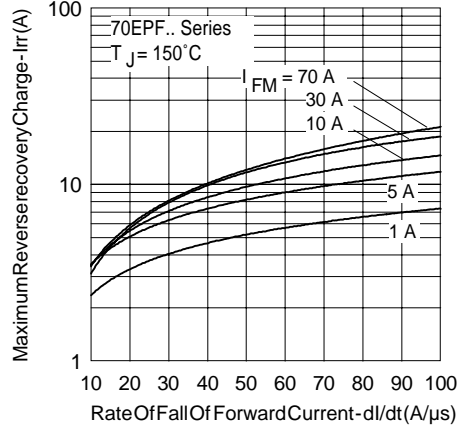

Fig. 13 - Recovery Current Characteristics,  $T_J = 150^\circ\text{C}$

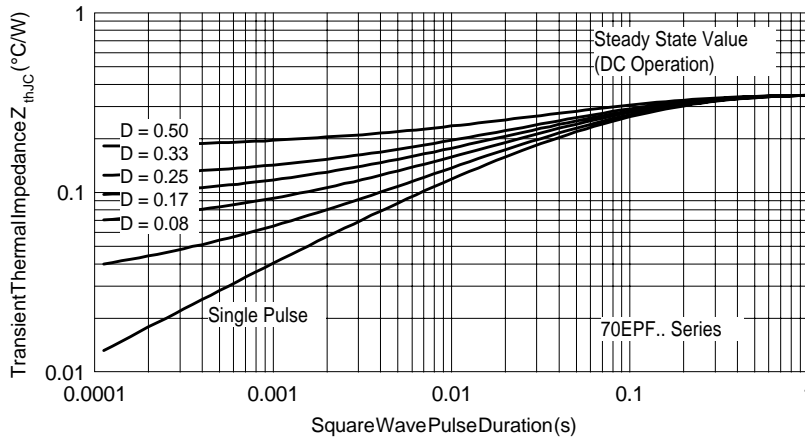

Fig. 14 - Thermal Impedance  $Z_{thJC}$  Characteristics

70EPF.. **QUIETIR** Series

Bulletin I2154 rev. C 12/02

International  
**IRF** Rectifier

Outline Table

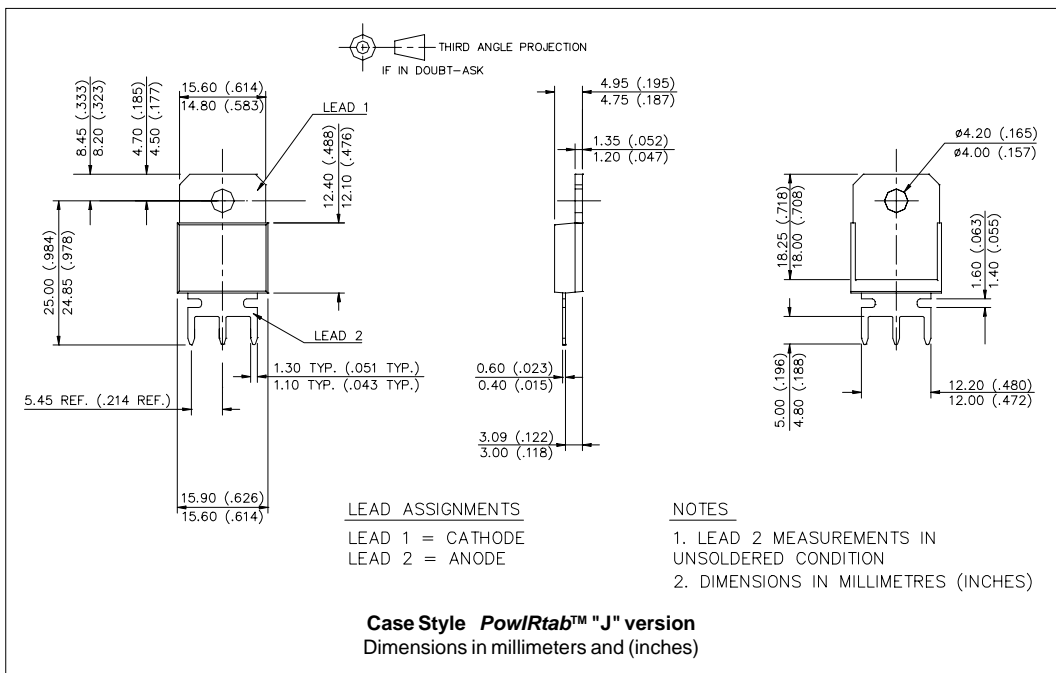
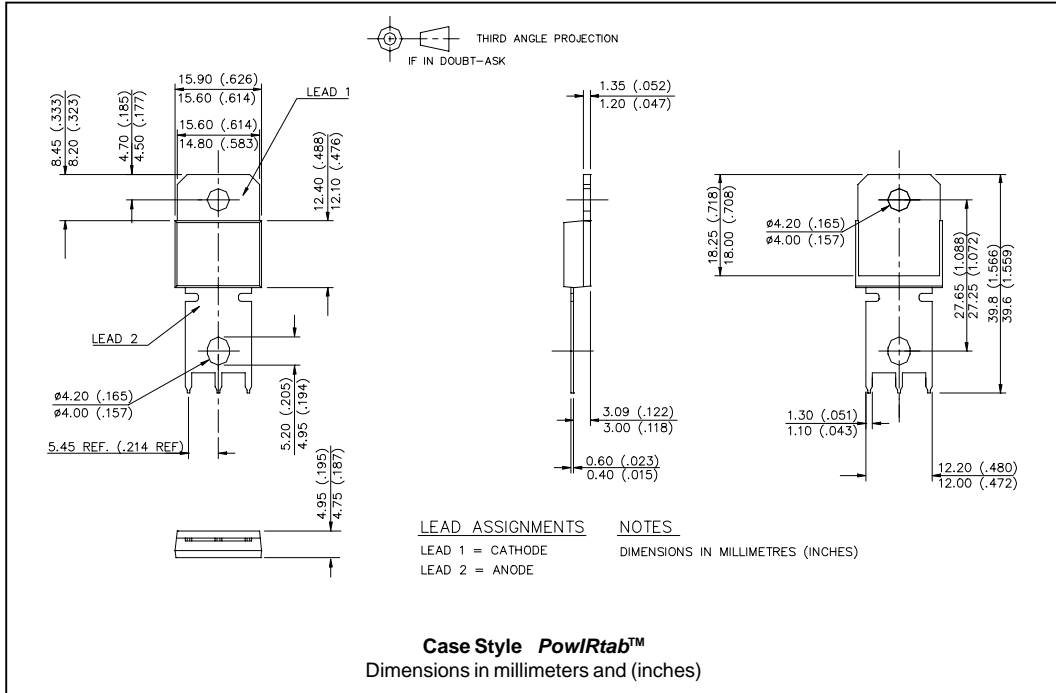

Ordering Information Table

Device Code	
70	E
P	F
06	J
①	②
③	④
⑤	⑥

<p><b>1</b> - Current Rating</p> <p><b>2</b> - Circuit Configuration: E = Single Diode</p> <p><b>3</b> - Package: P = TO-247AC</p> <p><b>4</b> - Type of Silicon: F = Fast Recovery</p> <p><b>5</b> - Voltage code: Code x 100 = <math>V_{RRM}</math> (*)</p> <p><b>6</b> - none = PowIRtab™ standard J = Short Lead Version</p>	<table border="1"> <tr><td>02 = 200V</td></tr> <tr><td>04 = 400V</td></tr> <tr><td>06 = 600V</td></tr> </table>	02 = 200V	04 = 400V	06 = 600V
02 = 200V				
04 = 400V				
06 = 600V				

Base Cathode

1

↑

2

Anode

(\*) for higher voltage up to 1600V contact factory

Data and specifications subject to change without notice.  
 This product has been designed and qualified for Industrial Level.  
 Qualification Standards can be found on IR's Web site.