



**Distributor of Texas Instruments: Excellent Integrated System Limited**

Datasheet of DS3862WMX - IC TXRX OCTAL HS TRAP BUS 20SOIC

Contact us: [sales@integrated-circuit.com](mailto:sales@integrated-circuit.com) Website: [www.integrated-circuit.com](http://www.integrated-circuit.com)

---

## **Excellent Integrated System Limited**

Stocking Distributor

Click to view price, real time Inventory, Delivery & Lifecycle Information:

[Texas Instruments](#)  
[DS3862WMX](#)

For any questions, you can email us directly:

[sales@integrated-circuit.com](mailto:sales@integrated-circuit.com)

## **DS3862**

***DS3862 Octal High Speed Trapezoidal Bus Transceiver***



Literature Number: SNOSBX5

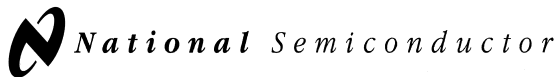

February 1995

## DS3862 Octal High Speed Trapezoidal Bus Transceiver

### General Description

The DS3862 is an octal high speed schottky bus transceiver intended for use with terminated 120Ω impedance lines. It is specifically designed to reduce noise in unbalanced transmission systems. The open collector drivers generate precise trapezoidal waveforms with rise and fall times of 9 ns (typical), which are relatively independent of capacitive loading conditions on the outputs. This reduces noise coupling to the adjacent lines without any appreciable impact on the maximum data rate obtainable with high speed bus transceivers. In addition, the receivers use a low pass filter in conjunction with a high speed comparator, to further enhance the noise immunity. Tightly controlled threshold levels on the receiver provide equal rejection to both negative and positive going noise pulses on the bus.

The external termination is intended to be a 180Ω resistor from the bus to 5V logic supply, together with a 390Ω resistor from the bus to ground. The bus can be terminated at one or both ends.

### Features

- Guaranteed A.C. specifications on noise immunity and propagation delay over the specified temperature and supply voltage range
- Temperature insensitive receiver thresholds track bus logic level and respond symmetrically to positive and negative going pulses
- Trapezoidal bus waveforms reduce noise coupling to adjacent lines
- Open collector driver output allows wire-or connection
- Advanced low power schottky technology
- Glitch free power up/down protection on driver and receiver outputs
- TTL compatible driver and control inputs, and receiver outputs
- Control logic is the same as the DS3896

### Logic and Connection Diagram

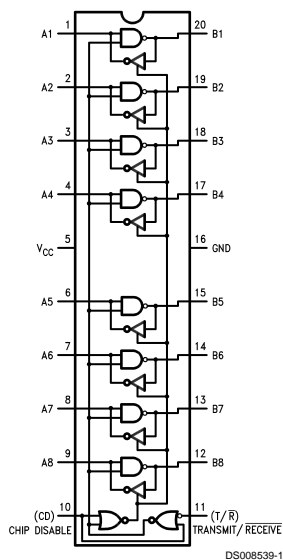

Order Number DS3862J, DS3862N or DS3862WM  
 See NS Package Number J20A, N20A or M20B

DS3862 Octal High Speed Trapezoidal Bus Transceiver

### Absolute Maximum Ratings (Note 1)

If Military/Aerospace specified devices are required, please contact the National Semiconductor Sales Office/Distributors for availability and specifications.

Supply Voltage	6V
Control Input Voltage	5.5V
Driver Input and Receiver Output	5.5V
Receiver Input and Driver Output	5.5V
Power Dissipation	1400 mW

Storage Temperature Range	-65°C to +150°C
Lead Temperature (Soldering, 4 seconds)	260°C

### Recommended Operating Conditions

	Min	Max	Units
Supply Voltage, $V_{CC}$	4.75	5.25	V
Operating Free Air Temperature	0	70	°C

### Electrical Characteristics (Notes 2, 3)

0°C ≤ T<sub>A</sub> ≤ 70°C, 4.75V ≤ V<sub>CC</sub> ≤ 5.25V unless otherwise specified

Symbol	Parameter	Conditions	Min	Typ	Max	Units
<b>Driver and Control Inputs:</b>						
V <sub>IH</sub>	Logical "1" Input Voltage		2.0			V
V <sub>IL</sub>	Logical "0" Input Voltage				0.8	V
I <sub>I</sub>	Logical "1" Input Current	An = V <sub>CC</sub>			1	mA
I <sub>IH</sub>	Logical "1" Input Current	An = 2.4V			40	μA
I <sub>IHC</sub>	Logical "1" Input Current	CD = T/R = 2.4V			80	μA
I <sub>IL</sub>	Logical "0" Input Current	An = 0.4V		-1	-1.6	mA
I <sub>ILC</sub>	CD & T/R Logical "0" Input Current	CD = T/R = 0.4V		-180	-400	μA
V <sub>CL</sub>	Input Diode Clamp Voltage	I <sub>clamp</sub> = -12 mA		-0.9	-1.5	V
<b>Driver Output/Receiver Input</b>						
V <sub>OLB</sub>	Low Level Bus Voltage	An = T/R = 2V, I <sub>bus</sub> = 100 mA		0.6	0.9	V
I <sub>IHB</sub>	Logical "1" Bus Current	An = 0.8V, Bn = 4V, V <sub>CC</sub> = 5.25V and 0V		10	100	μA
I <sub>ILB</sub>	Logical "0" Bus Current	An = 0.8V, Bn = 0V, V <sub>CC</sub> = 5.25V and 0V			100	μA
V <sub>TH</sub>	Input Threshold	V <sub>CC</sub> = 5V	1.5	1.7	1.9	V
<b>Receiver Output</b>						
V <sub>OH</sub>	Logical "1" Output Voltage	Bn = 0.9V, I <sub>oh</sub> = -400μA	2.4	3.2		V
V <sub>OL</sub>	Logical "0" Output Voltage	Bn = 4V, I <sub>ol</sub> = 16 mA		0.35	0.5	V
I <sub>OS</sub>	Output Short Circuit Current	Bn = 0.9V	-20	-70	-100	mA
I <sub>CC</sub>	Supply Current	V <sub>CC</sub> = 5.25V		90	135	mA

**Note 1:** "Absolute Maximum Ratings" are those beyond which the safety of the device cannot be guaranteed. They are not meant to imply that device should be operated at these limits. The table of "Electrical Characteristics" provide conditions for actual device operation.

**Note 2:** All currents into device pins are positive; all currents out of device pins are negative. All voltages are referenced to device ground unless otherwise specified.

**Note 3:** All typicals are given for V<sub>CC</sub> = 5V and T<sub>A</sub> = 25°C.

### Switching Characteristics

0°C ≤ T<sub>A</sub> ≤ 70°C, 4.75V ≤ V<sub>CC</sub> ≤ 5.25V unless otherwise specified

Symbol	Parameter	Conditions	Min	Typ	Max	Units
<b>Driver:</b>						
t <sub>DLH</sub>	An to Bn	CD = 0.8V, T/R = 2.0V, VL = 5V (Figure 1)		12	20	ns
t <sub>DHL</sub>				12	20	ns
t <sub>DLHC</sub>	CD to Bn	An = T/R = 2.0V, VL = 5V, (Figure 1)		12	20	ns
t <sub>DHLC</sub>				15	25	ns
t <sub>DLHT</sub>	T/R to Bn	VCI = An, VC = 5V, (Figure 2)		20	30	ns
t <sub>DHLT</sub>		CD = 0.8V, RC = 390Ω, CL = 30 pF RL1 = 91Ω, RL2 = 200Ω, VL = 5V		25	40	ns
t <sub>R</sub>	Driver Output Rise Time	CD = 0.8V, T/R = 2V, VL = 5V (Figure 1)	4	9	20	ns
t <sub>F</sub>	Driver Output Fall Time		4	9	20	ns

**Switching Characteristics** (Continued)

0°C ≤ T<sub>A</sub> ≤ 70°C, 4.75V ≤ V<sub>CC</sub> ≤ 5.25V unless otherwise specified

Symbol	Parameter	Conditions	Min	Typ	Max	Units
<b>Receiver:</b>						
t <sub>RLH</sub>	Bn to An	CD = 0.8V, T/R̄ = 0.8V (Figure 3)		15	25	ns
t <sub>RHL</sub>				15	25	ns
t <sub>RLZC</sub>	CD to An	Bn = 2.0V, T/R̄ = 0.8V, CL = 5 pF RL1 = 390Ω, RL2 = NC, VL = 5V (Figure 4)		15	25	ns
t <sub>RZLC</sub>		Bn = 2.0V, T/R̄ = 0.8V, CL = 30 pF RL1 = 390Ω, RL2 = 1.6K, VL = 5V (Figure 4)		10	20	ns
t <sub>RHZC</sub>		Bn = 0.8V, T/R̄ = 0.8V, VL = 0V, RL1 = 390Ω, RL2 = NC, CL = 5 pF (Figure 4)		5	10	ns
t <sub>RZHC</sub>		Bn = 0.8V, T/R̄ = 0.8V, VL = 0V, RL1 = NC, RL2 = 1.6K, CL = 30 pF (Figure 4)		8	15	ns
t <sub>RLZT</sub>	T/R̄ to An	VCI = Bn, VC = 3.4V, RC = 39Ω CD = 0.8V, VL = 5V, RL1 = 390Ω, RL2 = NC, CL = 5 pF (Figure 2)		20	30	ns
t <sub>RZLT</sub>		VCI = Bn, VC = 3.4V, RC = 39Ω, CD = 0.8V, VL = 5V, RL1 = 390Ω, RL2 = 1.6K, CL = 30 pF (Figure 2)		30	45	ns
t <sub>RHZT</sub>		VCI = Bn, VC = 0V, RC = 39Ω CD = 0.8V, VL = 0V, RL1 = 390Ω, RL2 = NC, CL = 5 pF (Figure 2)		5	10	ns
t <sub>RZHT</sub>		VCI = Bn, VC = 0V, RC = 39Ω, CD = 0.8V, VL = 0V, RL1 = NC RL2 = 1.6K, CL = 30 pF (Figure 2)		10	20	ns
t <sub>NR</sub>	Receiver Noise Rejection Pulse Width	(Figure 5)	9	12		ns

Note: NC means open

**Switching Waveforms**

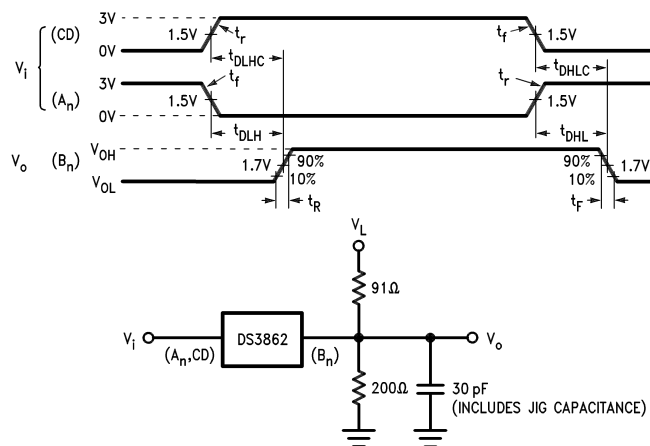

DS008539-2

Note: t<sub>r</sub> = t<sub>f</sub> ≤ 5 ns from 10% to 90%

**FIGURE 1. Driver Propagation Delays**

**Switching Waveforms** (Continued)

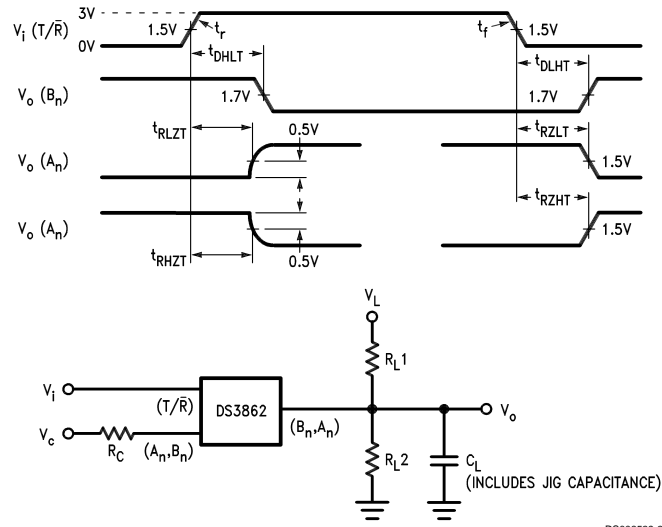

DS008539-3

Note:  $t_r = t_f \leq 5$  ns from 10% to 90%

**FIGURE 2. Propagation Delay From T/R Pin to An or Bn.**

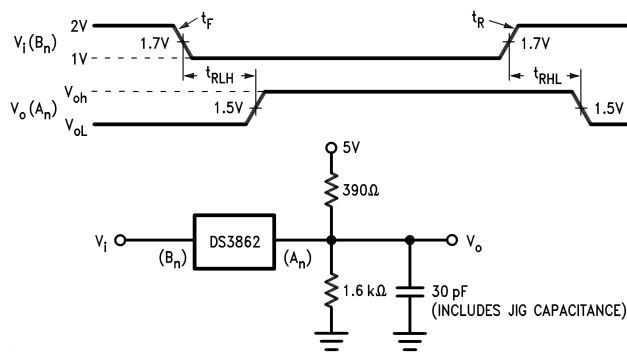

DS008539-4

Note:  $t_R = t_F \leq 10$  ns from 10% to 90%

**FIGURE 3. Receiver Propagation Delays**

**Switching Waveforms** (Continued)

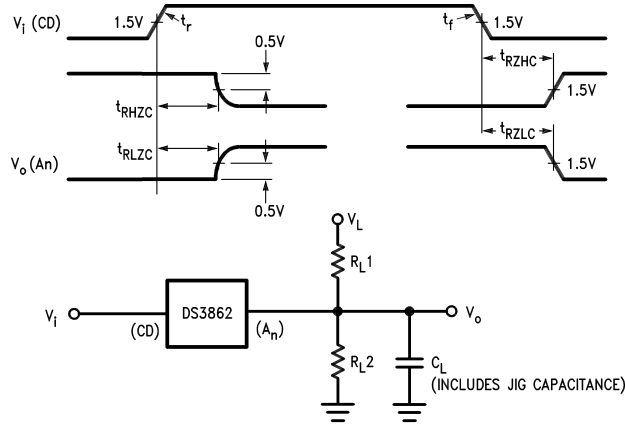

DS008539-5

Note:  $t_r = t_f \leq 5$  ns from 10% to 90%

**FIGURE 4. Propagation Delay From CD Pin to An**

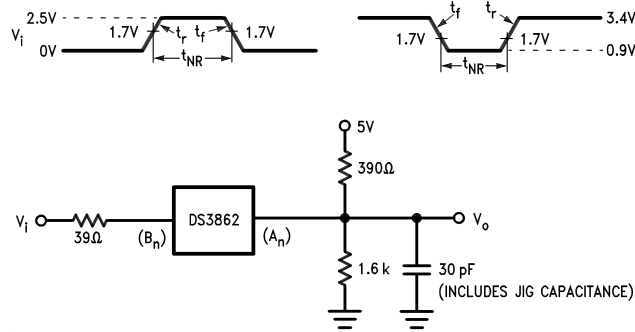

DS008539-6

Note:  $t_r = t_f = 2$  ns from 10% to 90%

**FIGURE 5. Receiver Noise Immunity: No Response at Output Input Waveform.**

**Typical Application**

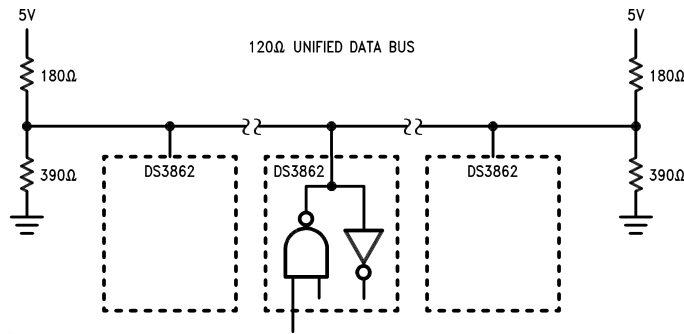

DS008539-7

**Physical Dimensions** inches (millimeters) unless otherwise noted

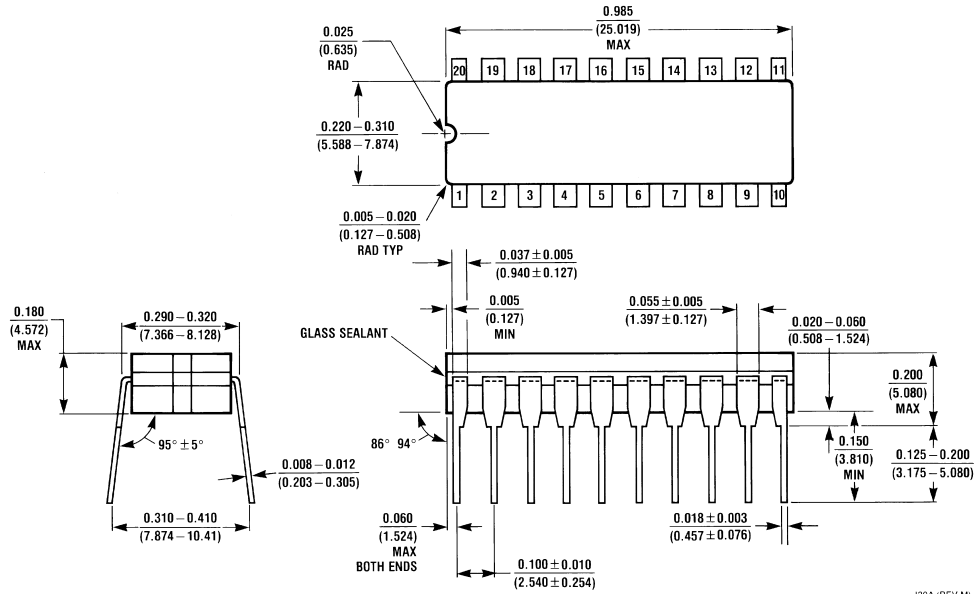

**Ceramic Dual-In-Line Package (J)**  
 Order Number DS3862J  
 NS Package J20A

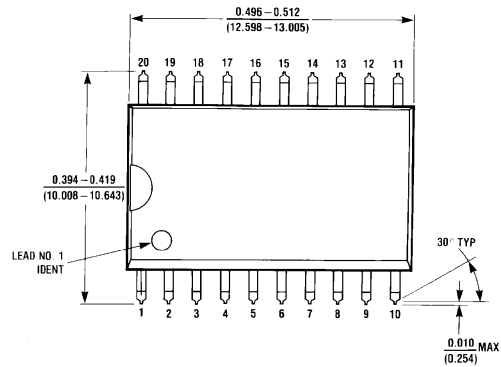

**20-Lead Molded Small Outline Package (M)**  
 Order Number DS3862WM  
 NS Package M20B



**Physical Dimensions** inches (millimeters) unless otherwise noted (Continued)

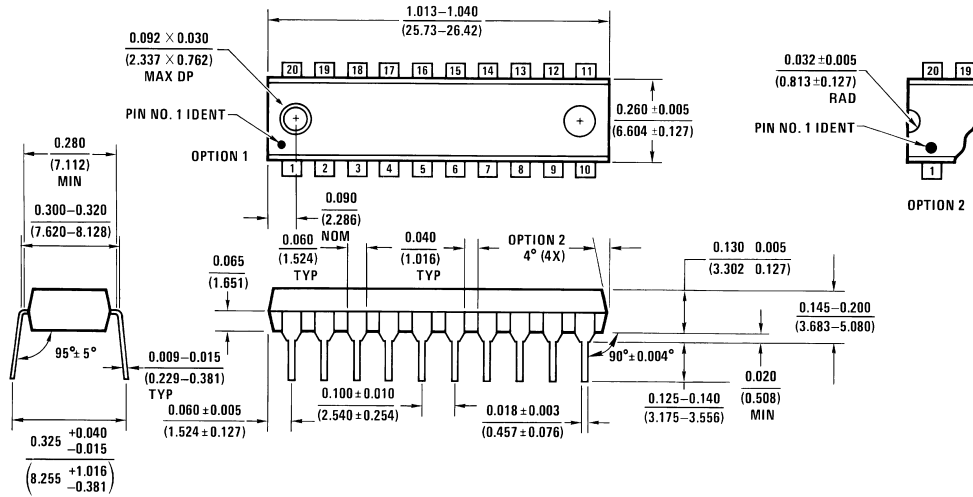

**Molded Dual-In-Line Package (N)**  
**Order Number DS3862N**  
**NS Package N20A**

N20A (REV G)

**LIFE SUPPORT POLICY**

NATIONAL'S PRODUCTS ARE NOT AUTHORIZED FOR USE AS CRITICAL COMPONENTS IN LIFE SUPPORT DEVICES OR SYSTEMS WITHOUT THE EXPRESS WRITTEN APPROVAL OF THE PRESIDENT AND GENERAL COUNSEL OF NATIONAL SEMICONDUCTOR CORPORATION. As used herein:

1. Life support devices or systems are devices or systems which, (a) are intended for surgical implant into the body, or (b) support or sustain life, and whose failure to perform when properly used in accordance with instructions for use provided in the labeling, can be reasonably expected to result in a significant injury to the user.
2. A critical component is any component of a life support device or system whose failure to perform can be reasonably expected to cause the failure of the life support device or system, or to affect its safety or effectiveness.

**National Semiconductor Corporation**  
 Americas  
 Tel: 1-800-272-9959  
 Fax: 1-800-737-7018  
 Email: support@nsc.com

**National Semiconductor Europe**  
 Fax: +49 (0) 1 80-530 85 86  
 Email: europe.support@nsc.com  
 Deutsch Tel: +49 (0) 1 80-530 85 85  
 English Tel: +49 (0) 1 80-532 78 32  
 Français Tel: +49 (0) 1 80-532 93 58  
 Italiano Tel: +49 (0) 1 80-534 16 80

**National Semiconductor Asia Pacific Customer Response Group**  
 Tel: 65-2544466  
 Fax: 65-2504466  
 Email: sea.support@nsc.com

**National Semiconductor Japan Ltd.**  
 Tel: 81-3-5639-7560  
 Fax: 81-3-5639-7507

www.national.com

### IMPORTANT NOTICE

Texas Instruments Incorporated and its subsidiaries (TI) reserve the right to make corrections, modifications, enhancements, improvements, and other changes to its products and services at any time and to discontinue any product or service without notice. Customers should obtain the latest relevant information before placing orders and should verify that such information is current and complete. All products are sold subject to TI's terms and conditions of sale supplied at the time of order acknowledgment.

TI warrants performance of its hardware products to the specifications applicable at the time of sale in accordance with TI's standard warranty. Testing and other quality control techniques are used to the extent TI deems necessary to support this warranty. Except where mandated by government requirements, testing of all parameters of each product is not necessarily performed.

TI assumes no liability for applications assistance or customer product design. Customers are responsible for their products and applications using TI components. To minimize the risks associated with customer products and applications, customers should provide adequate design and operating safeguards.

TI does not warrant or represent that any license, either express or implied, is granted under any TI patent right, copyright, mask work right, or other TI intellectual property right relating to any combination, machine, or process in which TI products or services are used. Information published by TI regarding third-party products or services does not constitute a license from TI to use such products or services or a warranty or endorsement thereof. Use of such information may require a license from a third party under the patents or other intellectual property of the third party, or a license from TI under the patents or other intellectual property of TI.

Reproduction of TI information in TI data books or data sheets is permissible only if reproduction is without alteration and is accompanied by all associated warranties, conditions, limitations, and notices. Reproduction of this information with alteration is an unfair and deceptive business practice. TI is not responsible or liable for such altered documentation. Information of third parties may be subject to additional restrictions.

Resale of TI products or services with statements different from or beyond the parameters stated by TI for that product or service voids all express and any implied warranties for the associated TI product or service and is an unfair and deceptive business practice. TI is not responsible or liable for any such statements.

TI products are not authorized for use in safety-critical applications (such as life support) where a failure of the TI product would reasonably be expected to cause severe personal injury or death, unless officers of the parties have executed an agreement specifically governing such use. Buyers represent that they have all necessary expertise in the safety and regulatory ramifications of their applications, and acknowledge and agree that they are solely responsible for all legal, regulatory and safety-related requirements concerning their products and any use of TI products in such safety-critical applications, notwithstanding any applications-related information or support that may be provided by TI. Further, Buyers must fully indemnify TI and its representatives against any damages arising out of the use of TI products in such safety-critical applications.

TI products are neither designed nor intended for use in military/aerospace applications or environments unless the TI products are specifically designated by TI as military-grade or "enhanced plastic." Only products designated by TI as military-grade meet military specifications. Buyers acknowledge and agree that any such use of TI products which TI has not designated as military-grade is solely at the Buyer's risk, and that they are solely responsible for compliance with all legal and regulatory requirements in connection with such use.

TI products are neither designed nor intended for use in automotive applications or environments unless the specific TI products are designated by TI as compliant with ISO/TS 16949 requirements. Buyers acknowledge and agree that, if they use any non-designated products in automotive applications, TI will not be responsible for any failure to meet such requirements.

Following are URLs where you can obtain information on other Texas Instruments products and application solutions:

#### Products

Audio	<a href="http://www.ti.com/audio">www.ti.com/audio</a>
Amplifiers	<a href="http://amplifier.ti.com">amplifier.ti.com</a>
Data Converters	<a href="http://dataconverter.ti.com">dataconverter.ti.com</a>
DLP® Products	<a href="http://www.dlp.com">www.dlp.com</a>
DSP	<a href="http://dsp.ti.com">dsp.ti.com</a>
Clocks and Timers	<a href="http://www.ti.com/clocks">www.ti.com/clocks</a>
Interface	<a href="http://interface.ti.com">interface.ti.com</a>
Logic	<a href="http://logic.ti.com">logic.ti.com</a>
Power Mgmt	<a href="http://power.ti.com">power.ti.com</a>
Microcontrollers	<a href="http://microcontroller.ti.com">microcontroller.ti.com</a>
RFID	<a href="http://www.ti-rfid.com">www.ti-rfid.com</a>
OMAP Mobile Processors	<a href="http://www.ti.com/omap">www.ti.com/omap</a>
Wireless Connectivity	<a href="http://www.ti.com/wirelessconnectivity">www.ti.com/wirelessconnectivity</a>

#### Applications

Communications and Telecom	<a href="http://www.ti.com/communications">www.ti.com/communications</a>
Computers and Peripherals	<a href="http://www.ti.com/computers">www.ti.com/computers</a>
Consumer Electronics	<a href="http://www.ti.com/consumer-apps">www.ti.com/consumer-apps</a>
Energy and Lighting	<a href="http://www.ti.com/energy">www.ti.com/energy</a>
Industrial	<a href="http://www.ti.com/industrial">www.ti.com/industrial</a>
Medical	<a href="http://www.ti.com/medical">www.ti.com/medical</a>
Security	<a href="http://www.ti.com/security">www.ti.com/security</a>
Space, Avionics and Defense	<a href="http://www.ti.com/space-avionics-defense">www.ti.com/space-avionics-defense</a>
Transportation and Automotive	<a href="http://www.ti.com/automotive">www.ti.com/automotive</a>
Video and Imaging	<a href="http://www.ti.com/video">www.ti.com/video</a>

**TI E2E Community Home Page**

[e2e.ti.com](http://e2e.ti.com)

Mailing Address: Texas Instruments, Post Office Box 655303, Dallas, Texas 75265  
 Copyright © 2011, Texas Instruments Incorporated