

## Excellent Integrated System Limited

Stocking Distributor

Click to view price, real time Inventory, Delivery & Lifecycle Information:

[Texas Instruments](#)  
[SN75182N](#)

For any questions, you can email us directly:

[sales@integrated-circuit.com](mailto:sales@integrated-circuit.com)

## SN55182, SN75182 DUAL DIFFERENTIAL LINE RECEIVERS

SLLS092D – OCTOBER 1972 – REVISED APRIL 1998

- **Single 5-V Supply**
- **Differential Line Operation**
- **Dual Channels**
- **TTL Compatibility**
- **±15-V Common-Mode Input Voltage Range**
- **±15-V Differential Input Voltage Range**
- **Individual Channel Strobes**
- **Built-In Optional Line-Termination Resistor**
- **Individual Frequency Response Controls**
- **Designed for Use With Dual Differential Drivers SN55183 and SN75183**
- **Designed to Be Interchangeable With National Semiconductor DS7820A and DS8820A**

### description

The SN55182 and SN75182 dual differential line receivers are designed to sense small differential signals in the presence of large common-mode noise. These devices give TTL-compatible output signals as a function of the polarity of the differential input voltage. The frequency response of each channel can be easily controlled by a single external capacitor to provide immunity to differential noise spikes. The output goes to a high level when the inputs are open circuited. A strobe input (STRB) is provided that, when in the low level, disables the receiver and forces the output to a high level.

The receiver is of monolithic single-chip construction, and both halves of the dual circuits use common power-supply and ground terminals.

The SN55182 is characterized for operation over the full military temperature range of  $-55^{\circ}\text{C}$  to  $125^{\circ}\text{C}$ . The SN75182 is characterized for operation from  $0^{\circ}\text{C}$  to  $70^{\circ}\text{C}$ .

**SN55182 . . . J OR W PACKAGE  
SN75182 . . . N PACKAGE  
(TOP VIEW)**

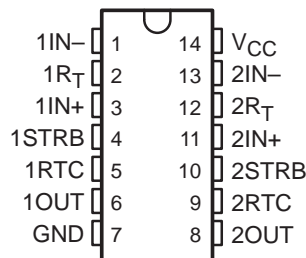

**SN55182 . . . FK PACKAGE  
(TOP VIEW)**

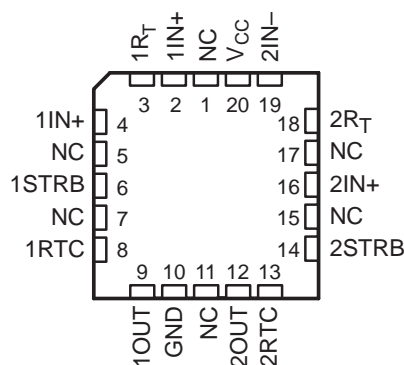

NC – No internal connection

**THE SN55182 IS NOT RECOMMENDED  
FOR NEW DESIGNS**

FUNCTION TABLE

INPUTS		OUTPUT OUT
STRB	V <sub>ID</sub>	
L	X	H
H	H	H
H	L	L

H =  $V_I \geq V_{IH \text{ min}}$  or  $V_{ID}$  more positive than  $V_{TH \text{ max}}$

L =  $V_I \leq V_{IL \text{ max}}$  or  $V_{ID}$  more negative than  $V_{TL \text{ max}}$

X = irrelevant



Please be aware that an important notice concerning availability, standard warranty, and use in critical applications of Texas Instruments semiconductor products and disclaimers thereto appears at the end of this data sheet.

PRODUCTION DATA information is current as of publication date. Products conform to specifications per the terms of Texas Instruments standard warranty. Production processing does not necessarily include testing of all parameters.

 **TEXAS  
INSTRUMENTS**

POST OFFICE BOX 655303 • DALLAS, TEXAS 75265

Copyright © 1998, Texas Instruments Incorporated

# SN55182, SN75182 DUAL DIFFERENTIAL LINE RECEIVERS

SLLS092D – OCTOBER 1972 – REVISED APRIL 1998

## logic symbol†

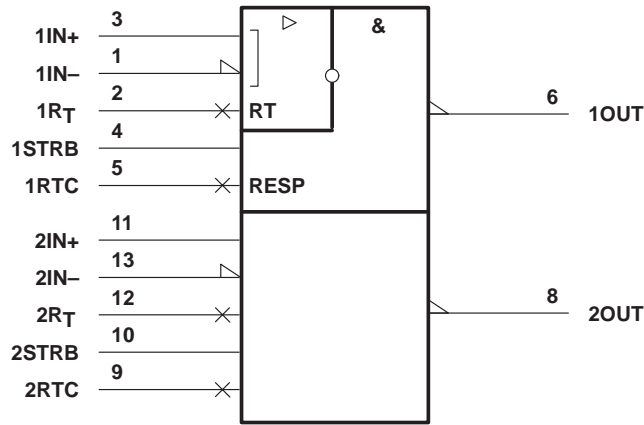

† This symbol is in accordance with ANSI/IEEE Std 91-1984 and IEC Publication 617-12.  
Pin numbers shown are for the J, N, and W packages.

## logic diagram (positive logic)

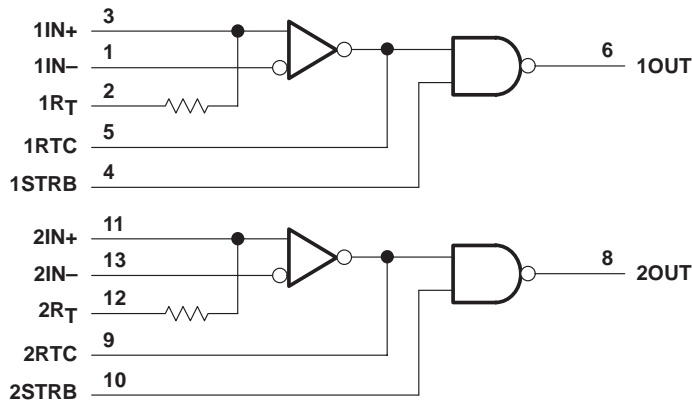

Pin numbers shown are for the J, N, and W packages.

**SN55182, SN75182  
DUAL DIFFERENTIAL LINE RECEIVERS**

SLLS092D – OCTOBER 1972 – REVISED APRIL 1998

**schematic (each receiver)**

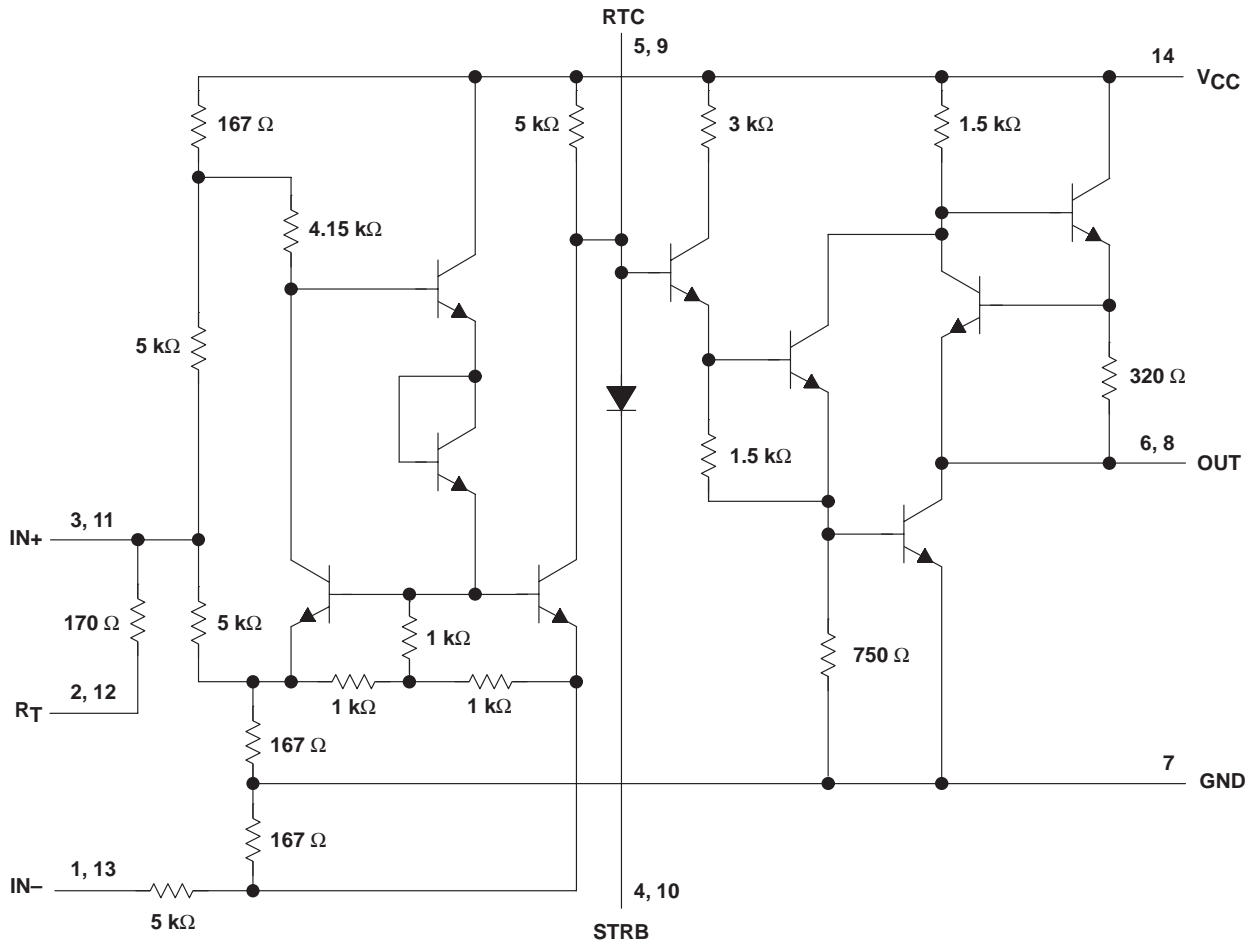

Resistor values shown are nominal.  
Pin numbers shown are for the J, N, and W packages.

# SN55182, SN75182 DUAL DIFFERENTIAL LINE RECEIVERS

SLLS092D – OCTOBER 1972 – REVISED APRIL 1998

## absolute maximum ratings over operating free-air temperature range (unless otherwise noted)†

Supply voltage, $V_{CC}$ (see Note 1)	8 V
Common-mode input voltage, $V_{IC}$	$\pm 20$ V
Differential input voltage, $V_{ID}$ (see Note 2)	$\pm 20$ V
Strobe input voltage, $V_{I(STRB)}$	8 V
Output sink current	50 mA
Continuous total power dissipation	See Dissipation Rating Table
Storage temperature range, $T_{stg}$	$-65^{\circ}\text{C}$ to $150^{\circ}\text{C}$
Lead temperature 1,6 mm (1/16 inch) from case for 10 seconds: N package	$260^{\circ}\text{C}$
Lead temperature 1,6 mm (1/16 inch) from case for 60 seconds: J or W package	$300^{\circ}\text{C}$
Case temperature for 60 seconds, $T_C$ : FK package	$260^{\circ}\text{C}$

† Stresses beyond those listed under “absolute maximum ratings” may cause permanent damage to the device. These are stress ratings only, and functional operation of the device at these or any other conditions beyond those indicated under “recommended operating conditions” is not implied. Exposure to absolute-maximum-rated conditions for extended periods may affect device reliability.

- NOTES: 1. All voltage values, except differential voltages, are with respect to network ground terminal.  
2. Differential voltage values are at the noninverting terminal with respect to the inverting terminal.

DISSIPATION RATING TABLE

PACKAGE	$T_A \leq 25^{\circ}\text{C}$	DERATING FACTOR	$T_A = 70^{\circ}\text{C}$	$T_A = 125^{\circ}\text{C}$
	POWER RATING	ABOVE $T_A = 25^{\circ}\text{C}$	POWER RATING	POWER RATING
FK‡	1375 mW	11.0 mW/°C	880 mW	275 mW
J‡	1375 mW	11.0 mW/°C	880 mW	275 mW
N	1150 mW	9.2 mW/°C	736 mW	–
W‡	1000 mW	8.0 mW/°C	640 mW	200 mW

‡ In the FK, J, and W packages, SN55182 chips are alloy mounted.

## recommended operating conditions

	SN55182			SN75182			UNIT
	MIN	NOM	MAX	MIN	NOM	MAX	
Supply voltage, $V_{CC}$	4.5	5	5.5	4.5	5	5.5	V
Common-mode input voltage, $V_{IC}$			$\pm 15$			$\pm 15$	V
High-level strobe input voltage, $V_{IH(STRB)}$	2.1		5.5	2.1		5.5	V
Low-level strobe input voltage, $V_{IL(STRB)}$	0		0.9	0		0.9	V
High-level output current, $I_{OH}$			-400			-400	$\mu\text{A}$
Low-level output current, $I_{OL}$			16			16	mA
Operating free-air temperature, $T_A$	-55		125	0		70	$^{\circ}\text{C}$

## SN55182, SN75182 DUAL DIFFERENTIAL LINE RECEIVERS

SLLS092D – OCTOBER 1972 – REVISED APRIL 1998

**electrical characteristics over recommended ranges of  $V_{CC}$ ,  $V_{IC}$ , and operating free-air temperature (unless otherwise noted)**

PARAMETER		TEST CONDITION†		MIN	TYP‡	MAX	UNIT	
$V_{IT+}$	Positive-going input threshold voltage	$V_O = 2.5\text{ V}$ , $I_{OH} = -400\ \mu\text{A}$	$V_{IC} = -3\text{ V to }3\text{ V}$			0.5	V	
			$V_{IC} = -15\text{ V to }15\text{ V}$			1		
$V_{IT-}$	Negative-going input threshold voltage	$V_O = 0.4\text{ V}$ , $I_{OL} = 16\text{ mA}$	$V_{IC} = -3\text{ V to }3\text{ V}$			-0.5	V	
			$V_{IC} = -15\text{ V to }15\text{ V}$			-1		
$V_{OH}$	High-level output voltage	$V_{ID} = 1\text{ V}$ , $V(\text{STRB}) = 2.1\text{ V}$ , $I_{OH} = -400\ \mu\text{A}$		2.5	4.2	5.5	V	
			$V_{ID} = -1\text{ V}$ , $V(\text{STRB}) = 0.4\text{ V}$ , $I_{OH} = -400\ \mu\text{A}$	2.5	4.2	5.5		
$V_{OL}$	Low-level output voltage	$V_{ID} = -1\text{ V}$ , $V(\text{STRB}) = 2.1\text{ V}$ , $I_{OL} = 16\text{ mA}$		0.25		0.4	V	
$I_I$	Input current		Inverting input	$V_{IC} = 15\text{ V}$		3	4.2	mA
				$V_{IC} = 0$		0	-0.5	
				$V_{IC} = -15\text{ V}$		-3	-4.2	
			Noninverting input	$V_{IC} = 15\text{ V}$		5	7	
				$V_{IC} = 0$		-1	-1.4	
				$V_{IC} = -15\text{ V}$		-7	-9.8	
$I_{IH}(\text{STRB})$	High-level strobe input current	$V(\text{STRB}) = 5.5\text{ V}$			5	$\mu\text{A}$		
$I_{IL}(\text{STRB})$	Low-level strobe input current	$V(\text{STRB}) = 0$		-1	-1.4	mA		
$r_i$	Input resistance		Inverting input	3.6	5		k $\Omega$	
			Noninverting input	1.8	2.5			
	Line-terminating resistance	$T_A = 25^\circ\text{C}$		120	170	250	$\Omega$	
$I_{OS}$	Short-circuit output current	$V_{CC} = 5.5\text{ V}$ , $V_O = 0$		-2.8	-4.5	-6.7	mA	
$I_{CC}$	Supply current (average per receiver)		$V_{IC} = 15\text{ V}$ , $V_{ID} = -1\text{ V}$		4.2	6	mA	
			$V_{IC} = 0$ , $V_{ID} = -0.5\text{ V}$		6.8	10.2		
			$V_{IC} = -15\text{ V}$ , $V_{ID} = -1\text{ V}$		9.4	14		

 † Unless otherwise noted,  $V(\text{STRB}) \geq 2.1\text{ V}$  or open.

 ‡ All typical values are at  $V_{CC} = 5\text{ V}$ ,  $V_{IC} = 0$ , and  $T_A = 25^\circ\text{C}$ .

**switching characteristics,  $V_{CC} = 5\text{ V}$ ,  $T_A = 25^\circ\text{C}$** 

PARAMETER		TEST CONDITIONS		MIN	TYP	MAX	UNIT
$t_{PLH(D)}$	Propagation delay time, low- to high-level output from differential input	$R_L = 400\ \Omega$ , $C_L = 15\text{ pF}$	see Figure 1		18	40	ns
$t_{PHL(D)}$	Propagation delay time, high- to low-level output from differential input	$R_L = 400\ \Omega$ , $C_L = 15\text{ pF}$	see Figure 1		31	45	ns
$t_{PLH(S)}$	Propagation delay time, low- to high-level output from STRB input	$R_L = 400\ \Omega$ , $C_L = 15\text{ pF}$	see Figure 1		9	30	ns
$t_{PHL(S)}$	Propagation delay time, high- to low-level output from STRB input	$R_L = 400\ \Omega$ , $C_L = 15\text{ pF}$	see Figure 1		15	25	ns

**SN55182, SN75182**  
**DUAL DIFFERENTIAL LINE RECEIVERS**

SLLS092D – OCTOBER 1972 – REVISED APRIL 1998

**PARAMETER MEASUREMENT INFORMATION**

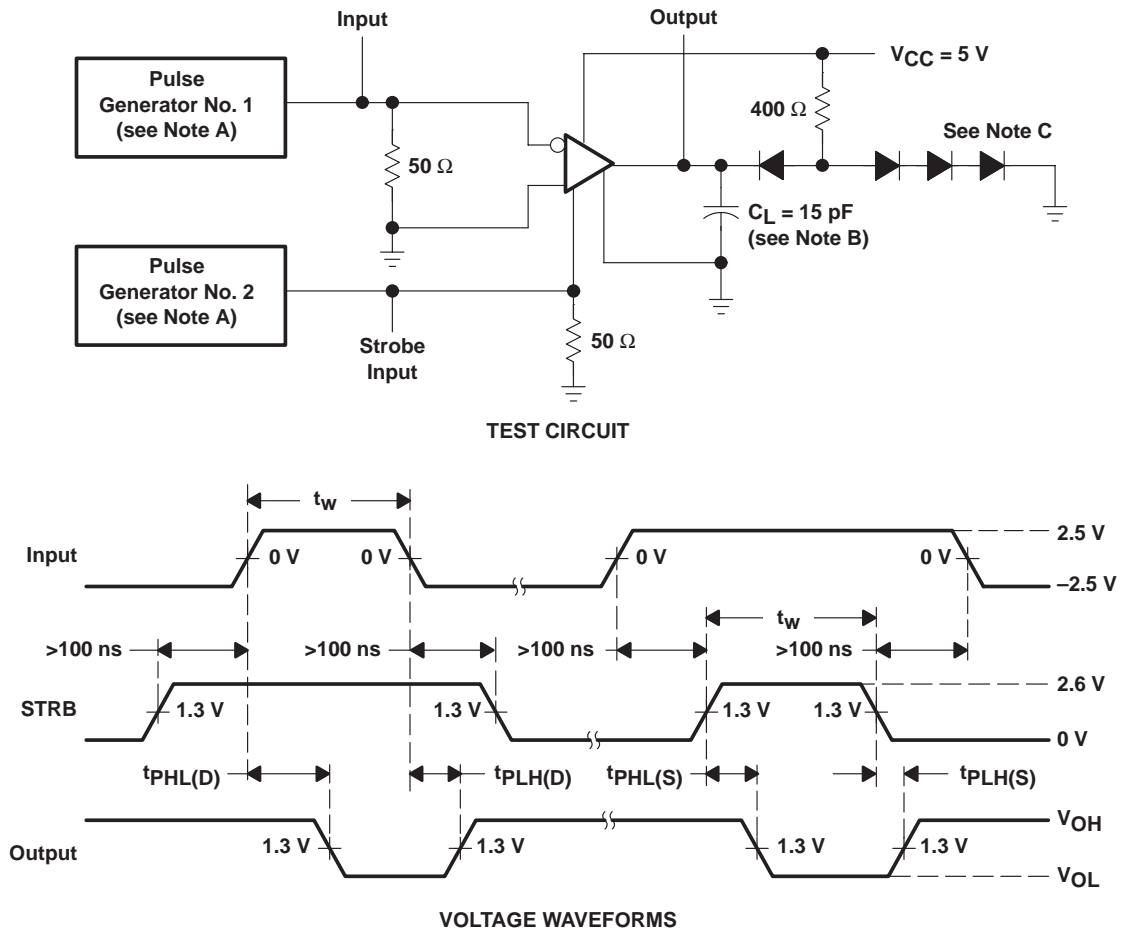

- NOTES: A. The pulse generators have the following characteristics:  $Z_O = 50 \Omega$ ,  $t_r \leq 10 \text{ ns}$ ,  $t_f \leq 10 \text{ ns}$ ,  $t_w = 0.5 \pm 0.1 \mu\text{s}$ ,  $\text{PRR} \leq 1 \text{ MHz}$ .  
 B.  $C_L$  includes probe and jig capacitance.  
 C. All diodes are 1N3064 or equivalent.

**Figure 1. Test Circuit and Voltage Waveforms**

**SN55182, SN75182  
DUAL DIFFERENTIAL LINE RECEIVERS**

SLLS092D - OCTOBER 1972 - REVISED APRIL 1998

**TYPICAL CHARACTERISTICS†**

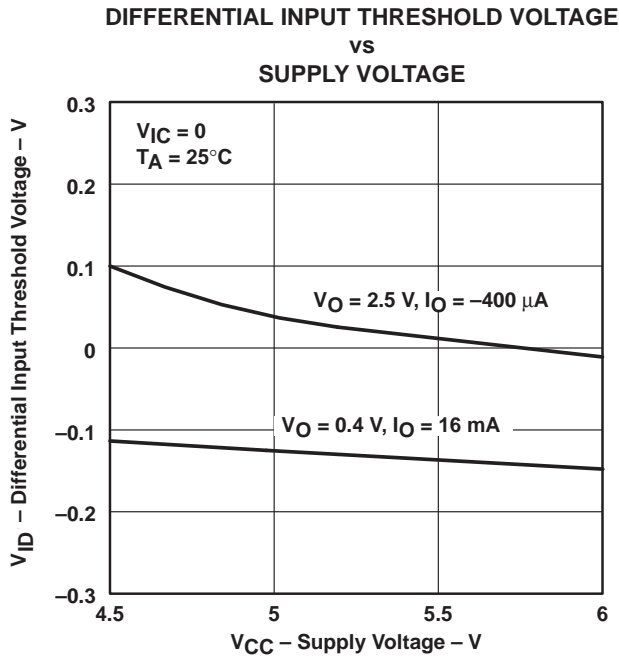

Figure 2

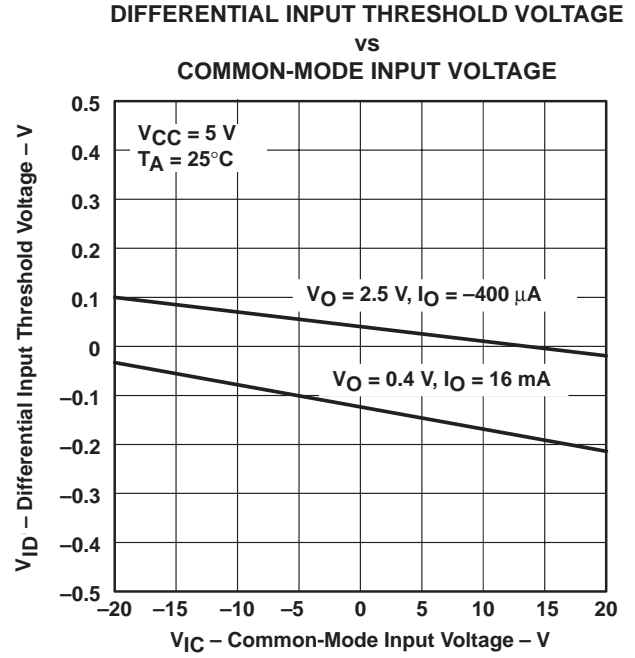

Figure 3

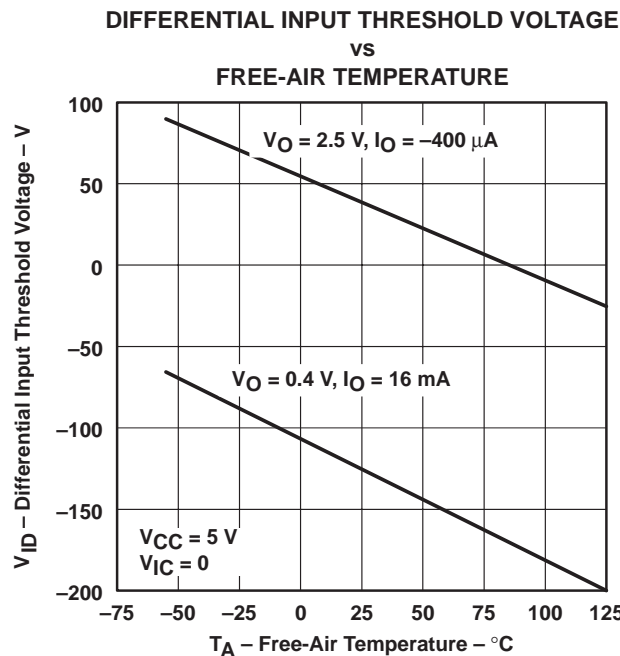

Figure 4

† Operation of the device at these or any other conditions beyond those indicated under "recommended operating conditions" is not implied.



**SN55182, SN75182**  
**DUAL DIFFERENTIAL LINE RECEIVERS**

SLLS092D – OCTOBER 1972 – REVISED APRIL 1998

**TYPICAL CHARACTERISTICS†**

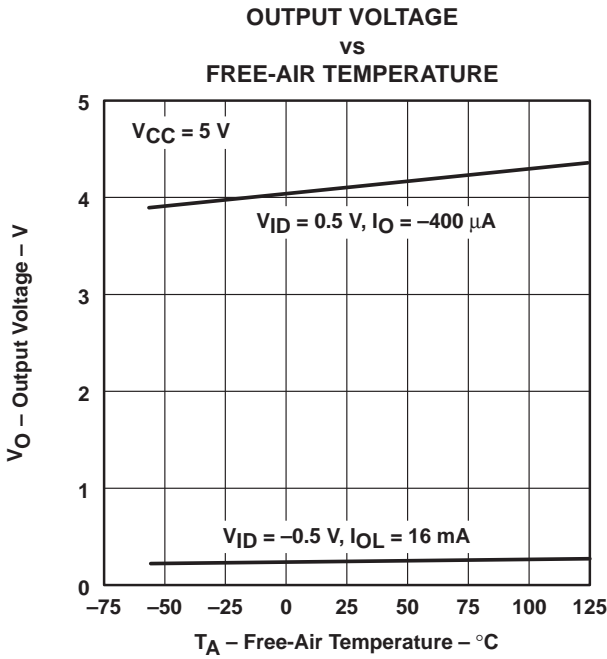

**Figure 5**

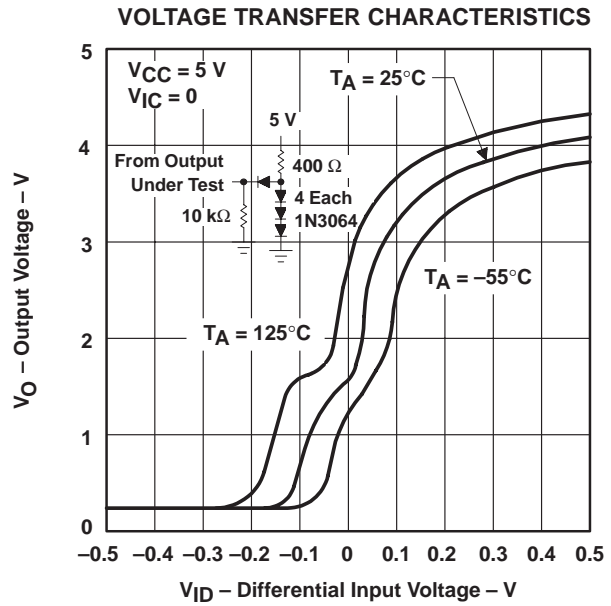

**Figure 6**

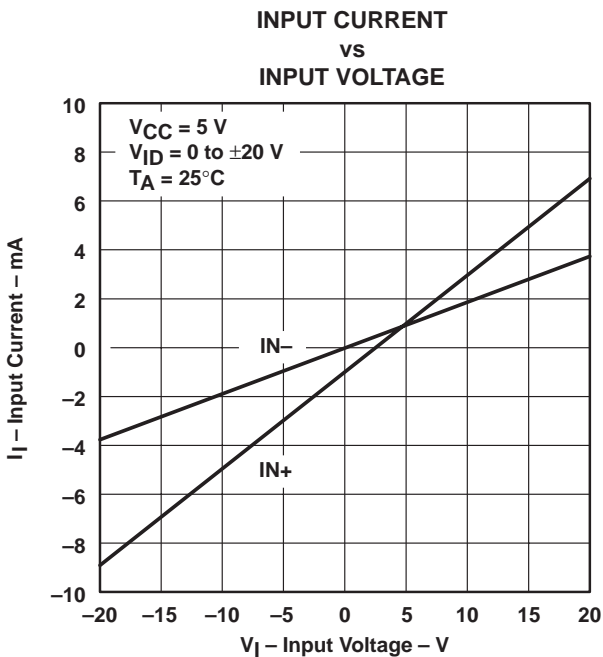

**Figure 7**

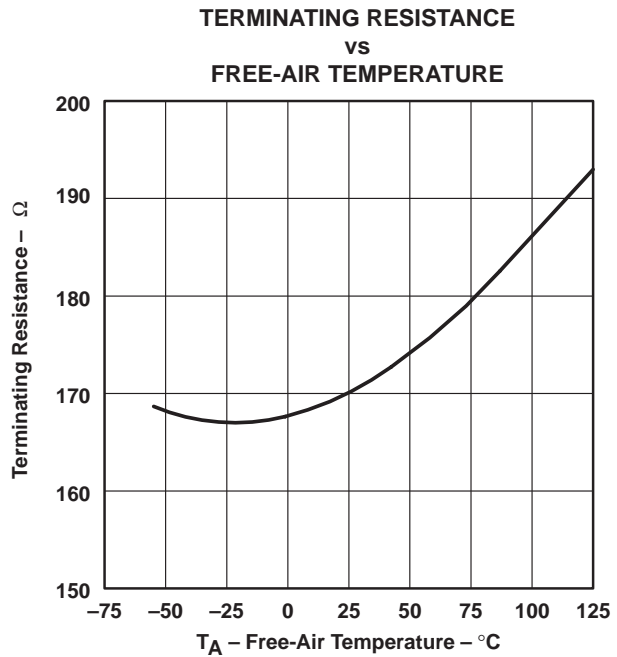

**Figure 8**

† Operation of the device at these or any other conditions beyond those indicated under "recommended operating conditions" is not implied.

**SN55182, SN75182  
DUAL DIFFERENTIAL LINE RECEIVERS**

SLLS092D – OCTOBER 1972 – REVISED APRIL 1998

**TYPICAL CHARACTERISTICS†**

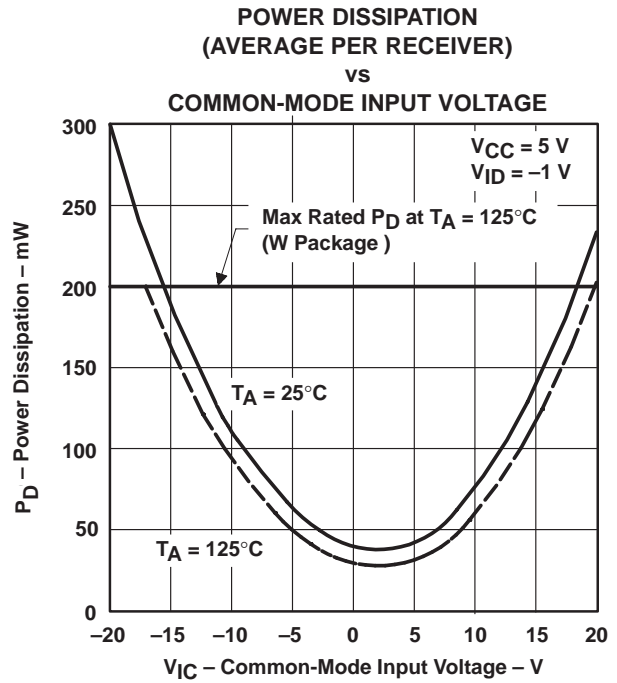
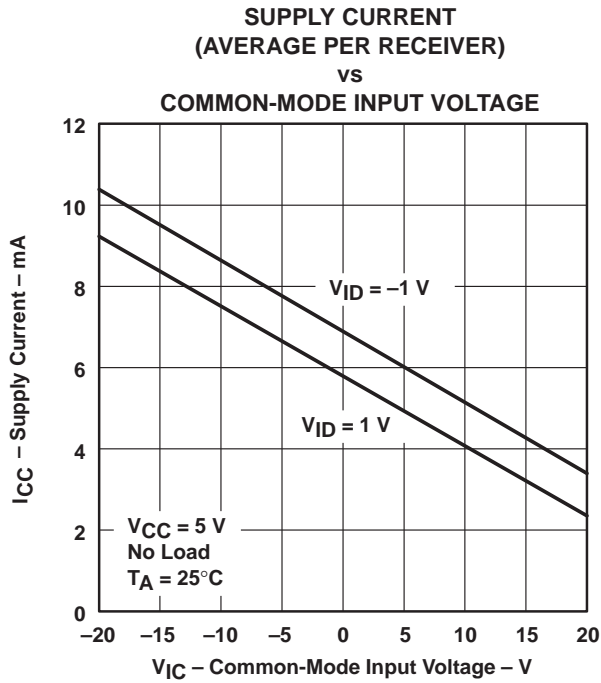

† Operation of the device at these or any other conditions beyond those indicated under "recommended operating conditions" is not implied.

**SN55182, SN75182**  
**DUAL DIFFERENTIAL LINE RECEIVERS**

SLLS092D – OCTOBER 1972 – REVISED APRIL 1998

**TYPICAL CHARACTERISTICS†**

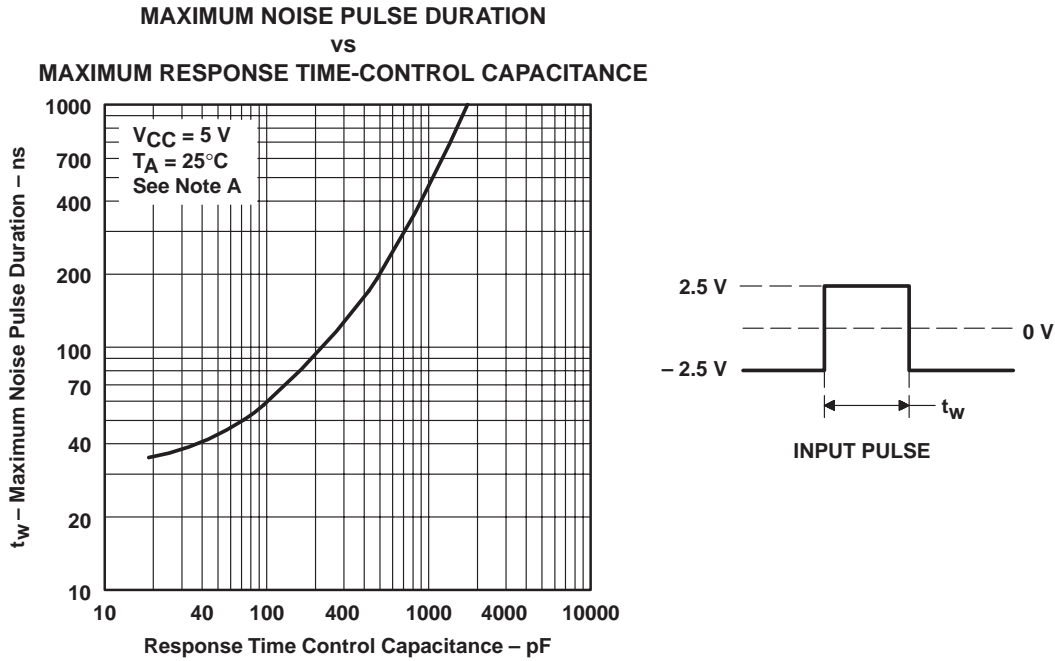

NOTE A: Figure 11 shows the maximum duration of the illustrated pulse that can be applied differentially without the output changing from the low to high level.

**Figure 11**

† Operation of the device at these or any other conditions beyond those indicated under "recommended operating conditions" is not implied.

TYPICAL CHARACTERISTICS†

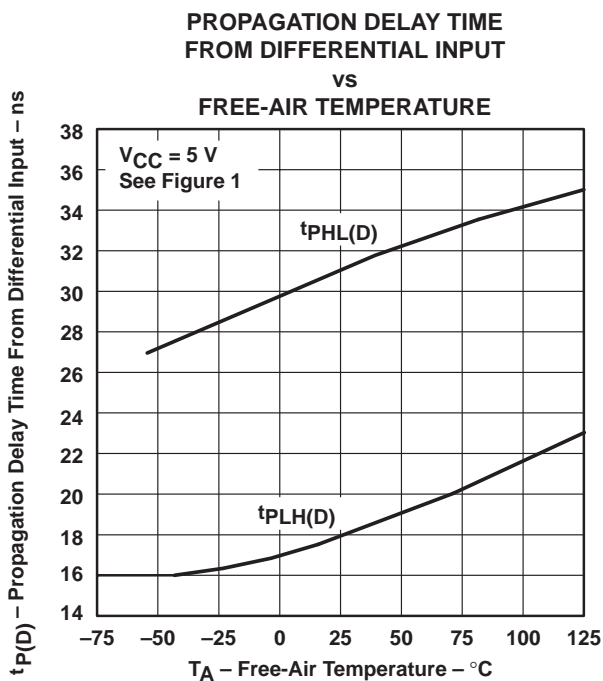

Figure 12

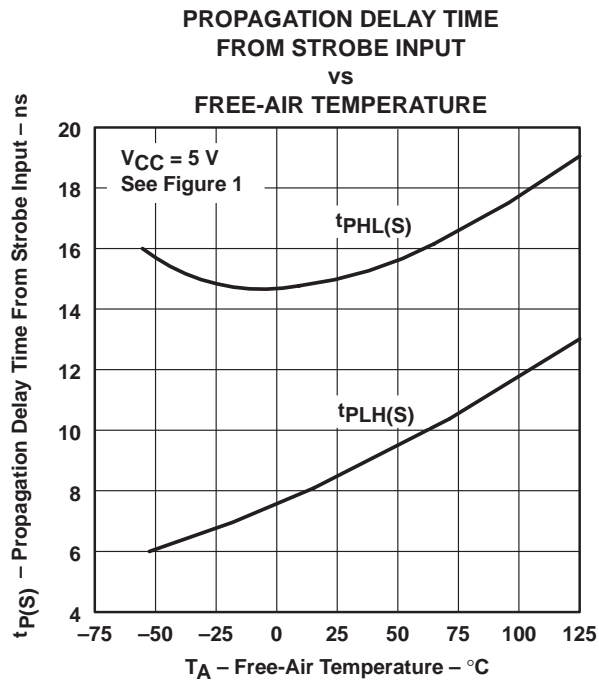

Figure 13

† Operation of the device at these or any other conditions beyond those indicated under "recommended operating conditions" is not implied.

**SN55182, SN75182**  
**DUAL DIFFERENTIAL LINE RECEIVERS**

SLLS092D – OCTOBER 1972 – REVISED APRIL 1998

**APPLICATION INFORMATION**

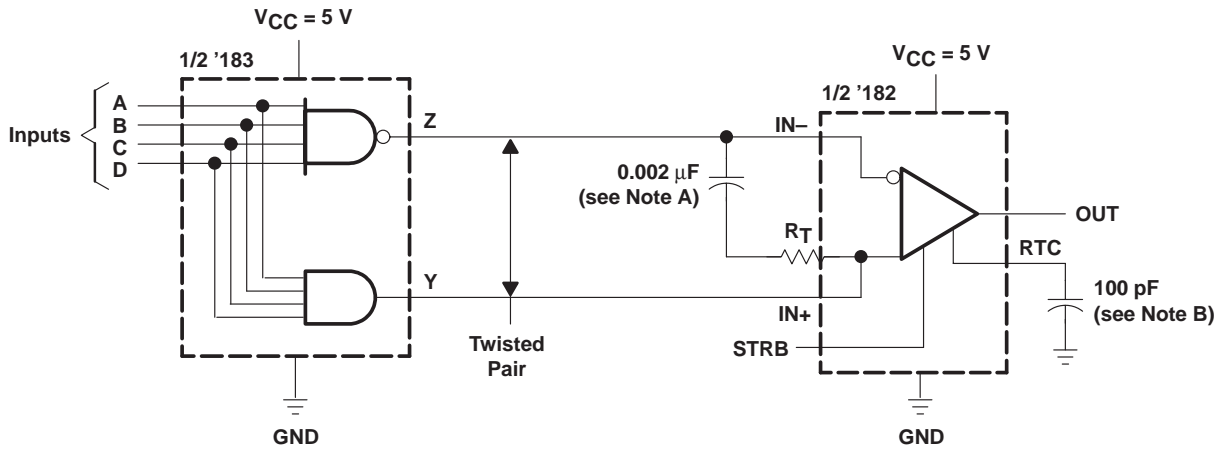

NOTES: A. When the inputs are open circuited, the output is high. A capacitor may be used for dc isolation of the line-terminating resistor. At the frequency of operation, the impedance of the capacitor should be relatively small.

Example: let  $f = 5 \text{ MHz}$   
 $C = 0.002 \mu\text{F}$

$$Z_{(C)} = \frac{1}{2\pi f C} = \frac{1}{2\pi(5 \times 10^6)(0.002 \times 10^{-6})}$$

$$Z_{(C)} \approx 16\Omega$$

B. Use of a capacitor to control response time is optional.

**Figure 14. Transmission of Digital Data Over Twisted-Pair Line**

**PACKAGING INFORMATION**

Orderable Device	Status (1)	Package Type	Package Drawing	Pins	Package Qty	Eco Plan (2)	Lead/Ball Finish (6)	MSL Peak Temp (3)	Op Temp (°C)	Device Marking (4/5)	Samples
5962-7900801VCA	ACTIVE	CDIP	J	14	1	TBD	A42	N / A for Pkg Type	-55 to 125	5962-7900801VC A SNV55182J	<a href="#">Samples</a>
5962-7900801VDA	ACTIVE	CFP	W	14	25	TBD	A42	N / A for Pkg Type	-55 to 125	5962-7900801VD A SNV55182W	<a href="#">Samples</a>
SN55182J	OBSOLETE	CDIP	J	14		TBD	Call TI	Call TI	-55 to 125		
SN75182D	ACTIVE	SOIC	D	14	50	Green (RoHS & no Sb/Br)	CU NIPDAU	Level-1-260C-UNLIM	0 to 70	SN75182	<a href="#">Samples</a>
SN75182DG4	ACTIVE	SOIC	D	14	50	Green (RoHS & no Sb/Br)	CU NIPDAU	Level-1-260C-UNLIM	0 to 70	SN75182	<a href="#">Samples</a>
SN75182DR	ACTIVE	SOIC	D	14	2500	Green (RoHS & no Sb/Br)	CU NIPDAU	Level-1-260C-UNLIM	0 to 70	SN75182	<a href="#">Samples</a>
SN75182DRE4	ACTIVE	SOIC	D	14	2500	Green (RoHS & no Sb/Br)	CU NIPDAU	Level-1-260C-UNLIM	0 to 70	SN75182	<a href="#">Samples</a>
SN75182N	ACTIVE	PDIP	N	14	25	Pb-Free (RoHS)	CU NIPDAU	N / A for Pkg Type	0 to 70	SN75182N	<a href="#">Samples</a>
SN75182NE4	ACTIVE	PDIP	N	14	25	Pb-Free (RoHS)	CU NIPDAU	N / A for Pkg Type	0 to 70	SN75182N	<a href="#">Samples</a>
SN75182NSR	ACTIVE	SO	NS	14	2000	Green (RoHS & no Sb/Br)	CU NIPDAU	Level-1-260C-UNLIM	0 to 70	SN75182	<a href="#">Samples</a>
SNJ55182FK	OBSOLETE	LCCC	FK	20		TBD	Call TI	Call TI	-55 to 125		
SNJ55182J	OBSOLETE	CDIP	J	14		TBD	Call TI	Call TI	-55 to 125		
SNJ55182W	OBSOLETE	CFP	W	14		TBD	Call TI	Call TI	0 to 70		

(1) The marketing status values are defined as follows:

**ACTIVE:** Product device recommended for new designs.

**LIFEBUY:** TI has announced that the device will be discontinued, and a lifetime-buy period is in effect.

**NRND:** Not recommended for new designs. Device is in production to support existing customers, but TI does not recommend using this part in a new design.

**PREVIEW:** Device has been announced but is not in production. Samples may or may not be available.

**OBSOLETE:** TI has discontinued the production of the device.

(2) Eco Plan - The planned eco-friendly classification: Pb-Free (RoHS), Pb-Free (RoHS Exempt), or Green (RoHS & no Sb/Br) - please check <http://www.ti.com/productcontent> for the latest availability information and additional product content details.

**TBD:** The Pb-Free/Green conversion plan has not been defined.



**Pb-Free (RoHS):** TI's terms "Lead-Free" or "Pb-Free" mean semiconductor products that are compatible with the current RoHS requirements for all 6 substances, including the requirement that lead not exceed 0.1% by weight in homogeneous materials. Where designed to be soldered at high temperatures, TI Pb-Free products are suitable for use in specified lead-free processes.

**Pb-Free (RoHS Exempt):** This component has a RoHS exemption for either 1) lead-based flip-chip solder bumps used between the die and package, or 2) lead-based die adhesive used between the die and leadframe. The component is otherwise considered Pb-Free (RoHS compatible) as defined above.

**Green (RoHS & no Sb/Br):** TI defines "Green" to mean Pb-Free (RoHS compatible), and free of Bromine (Br) and Antimony (Sb) based flame retardants (Br or Sb do not exceed 0.1% by weight in homogeneous material)

<sup>(3)</sup> MSL, Peak Temp. - The Moisture Sensitivity Level rating according to the JEDEC industry standard classifications, and peak solder temperature.

<sup>(4)</sup> There may be additional marking, which relates to the logo, the lot trace code information, or the environmental category on the device.

<sup>(5)</sup> Multiple Device Markings will be inside parentheses. Only one Device Marking contained in parentheses and separated by a "-" will appear on a device. If a line is indented then it is a continuation of the previous line and the two combined represent the entire Device Marking for that device.

<sup>(6)</sup> Lead/Ball Finish - Orderable Devices may have multiple material finish options. Finish options are separated by a vertical ruled line. Lead/Ball Finish values may wrap to two lines if the finish value exceeds the maximum column width.

**Important Information and Disclaimer:** The information provided on this page represents TI's knowledge and belief as of the date that it is provided. TI bases its knowledge and belief on information provided by third parties, and makes no representation or warranty as to the accuracy of such information. Efforts are underway to better integrate information from third parties. TI has taken and continues to take reasonable steps to provide representative and accurate information but may not have conducted destructive testing or chemical analysis on incoming materials and chemicals. TI and TI suppliers consider certain information to be proprietary, and thus CAS numbers and other limited information may not be available for release.

In no event shall TI's liability arising out of such information exceed the total purchase price of the TI part(s) at issue in this document sold by TI to Customer on an annual basis.

**OTHER QUALIFIED VERSIONS OF SN55182, SN55182-SP, SN75182 :**

● Catalog: [SN75182](#), [SN55182](#)

● Military: [SN55182](#)

● Space: [SN55182-SP](#)

NOTE: Qualified Version Definitions:

● Catalog - TI's standard catalog product

● Military - QML certified for Military and Defense Applications



**Distributor of Texas Instruments: Excellent Integrated System Limited**

Datasheet of SN75182N - IC DUAL DIFF LINE REC 14-DIP

Contact us: [sales@integrated-circuit.com](mailto:sales@integrated-circuit.com) Website: [www.integrated-circuit.com](http://www.integrated-circuit.com)

**PACKAGE OPTION ADDENDUM**

---



[www.ti.com](http://www.ti.com)

10-Jun-2014

- 
- Space - Radiation tolerant, ceramic packaging and qualified for use in Space-based application



**TAPE AND REEL INFORMATION**

**REEL DIMENSIONS**

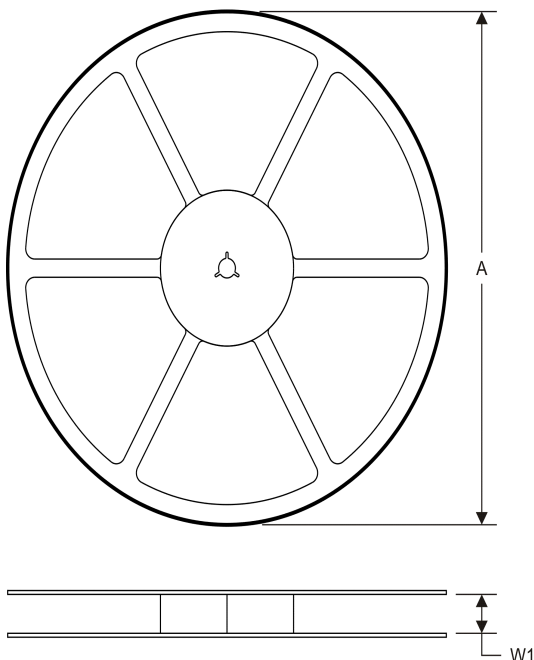

**TAPE DIMENSIONS**

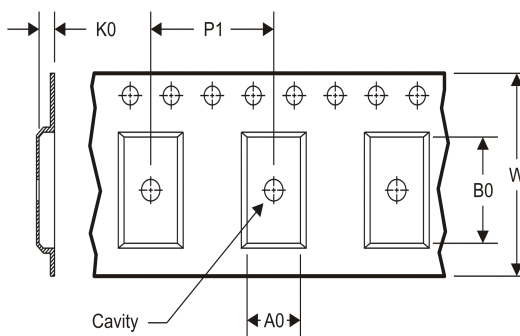

A0	Dimension designed to accommodate the component width
B0	Dimension designed to accommodate the component length
K0	Dimension designed to accommodate the component thickness
W	Overall width of the carrier tape
P1	Pitch between successive cavity centers

**TAPE AND REEL INFORMATION**

\*All dimensions are nominal

Device	Package Type	Package Drawing	Pins	SPQ	Reel Diameter (mm)	Reel Width W1 (mm)	A0 (mm)	B0 (mm)	K0 (mm)	P1 (mm)	W (mm)	Pin1 Quadrant
SN75182DR	SOIC	D	14	2500	330.0	16.4	6.5	9.0	2.1	8.0	16.0	Q1
SN75182NSR	SO	NS	14	2000	330.0	16.4	8.2	10.5	2.5	12.0	16.0	Q1

**TAPE AND REEL BOX DIMENSIONS**

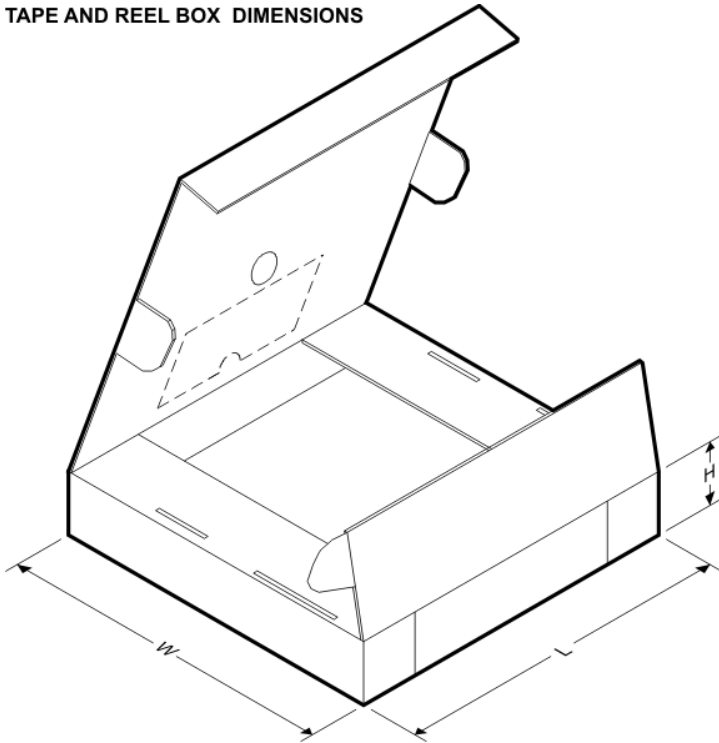

\*All dimensions are nominal

Device	Package Type	Package Drawing	Pins	SPQ	Length (mm)	Width (mm)	Height (mm)
SN75182DR	SOIC	D	14	2500	367.0	367.0	38.0
SN75182NSR	SO	NS	14	2000	367.0	367.0	38.0

J (R-GDIP-T\*\*)

14 LEADS SHOWN

CERAMIC DUAL IN-LINE PACKAGE

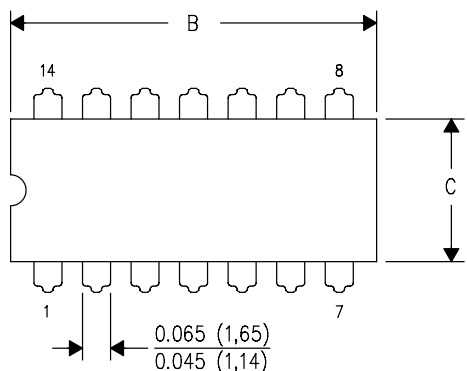

DIM \ PINS **	14	16	18	20
A	0.300 (7,62) BSC	0.300 (7,62) BSC	0.300 (7,62) BSC	0.300 (7,62) BSC
B MAX	0.785 (19,94)	.840 (21,34)	0.960 (24,38)	1.060 (26,92)
B MIN	—	—	—	—
C MAX	0.300 (7,62)	0.300 (7,62)	0.310 (7,87)	0.300 (7,62)
C MIN	0.245 (6,22)	0.245 (6,22)	0.220 (5,59)	0.245 (6,22)

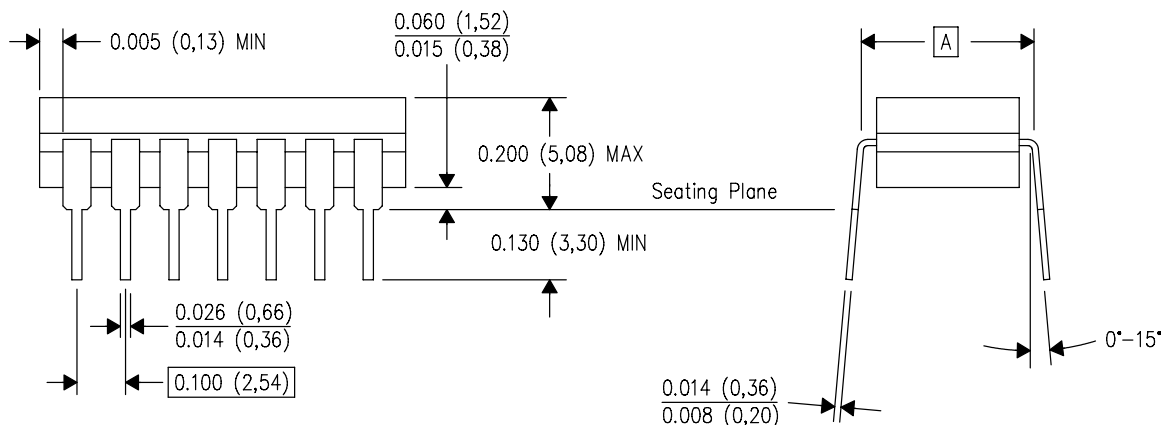

4040083/F 03/03

- NOTES:
- A. All linear dimensions are in inches (millimeters).
  - B. This drawing is subject to change without notice.
  - C. This package is hermetically sealed with a ceramic lid using glass frit.
  - D. Index point is provided on cap for terminal identification only on press ceramic glass frit seal only.
  - E. Falls within MIL STD 1835 GDIP1-T14, GDIP1-T16, GDIP1-T18 and GDIP1-T20.

**MECHANICAL DATA**

W (R-GDFP-F14)

CERAMIC DUAL FLATPACK

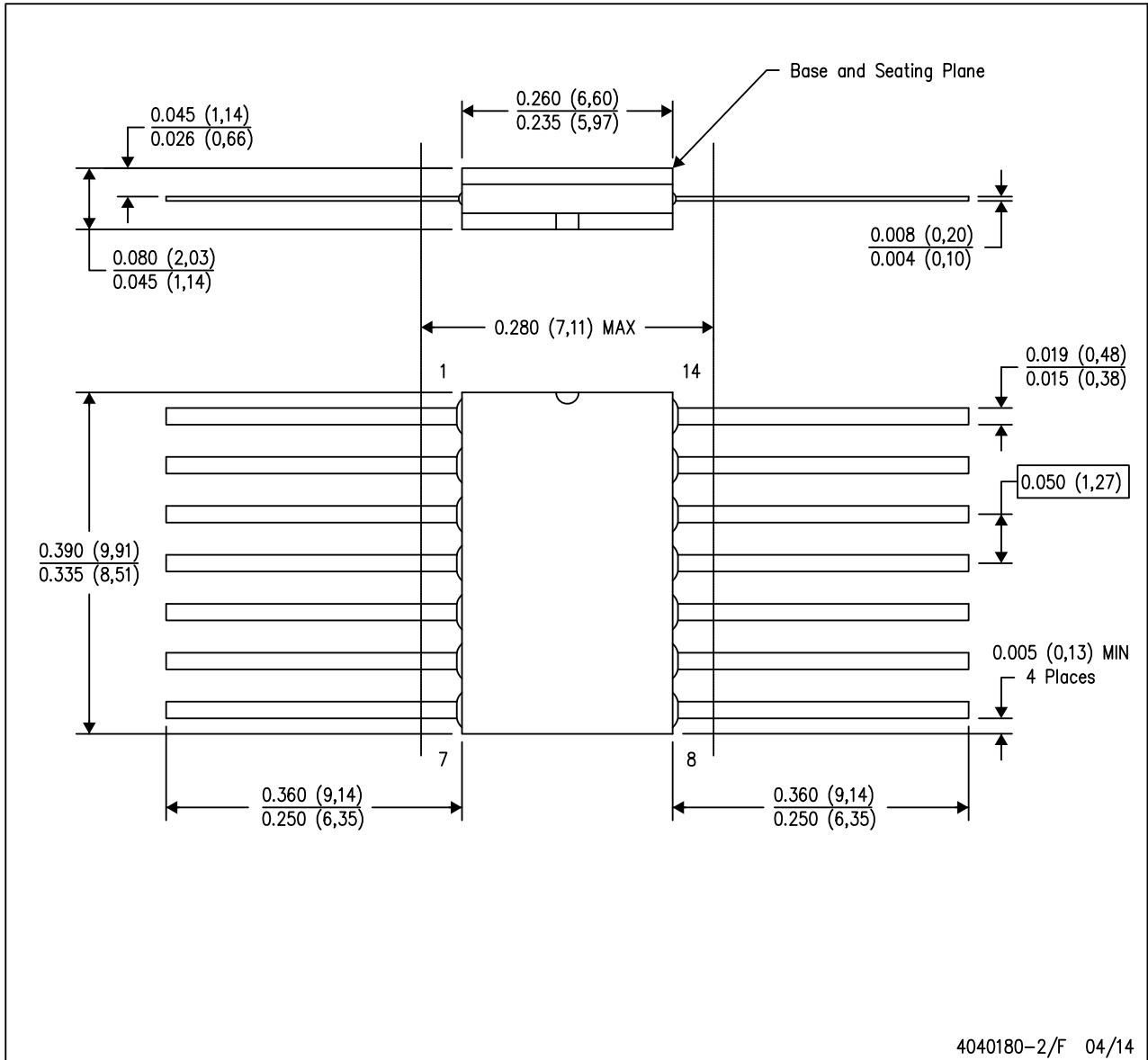

- NOTES:
- A. All linear dimensions are in inches (millimeters).
  - B. This drawing is subject to change without notice.
  - C. This package can be hermetically sealed with a ceramic lid using glass frit.
  - D. Index point is provided on cap for terminal identification only.
  - E. Falls within MIL STD 1835 GDFP1-F14

FK (S-CQCC-N\*\*)

LEADLESS CERAMIC CHIP CARRIER

28 TERMINAL SHOWN

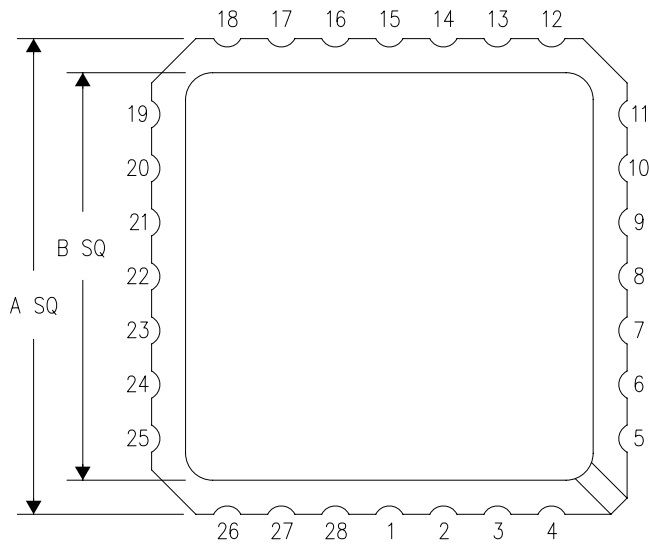

NO. OF TERMINALS **	A		B	
	MIN	MAX	MIN	MAX
20	0.342 (8,69)	0.358 (9,09)	0.307 (7,80)	0.358 (9,09)
28	0.442 (11,23)	0.458 (11,63)	0.406 (10,31)	0.458 (11,63)
44	0.640 (16,26)	0.660 (16,76)	0.495 (12,58)	0.560 (14,22)
52	0.740 (18,78)	0.761 (19,32)	0.495 (12,58)	0.560 (14,22)
68	0.938 (23,83)	0.962 (24,43)	0.850 (21,6)	0.858 (21,8)
84	1.141 (28,99)	1.165 (29,59)	1.047 (26,6)	1.063 (27,0)

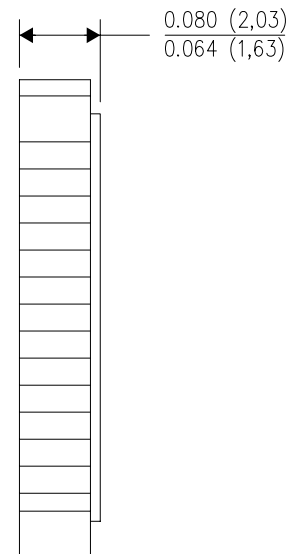
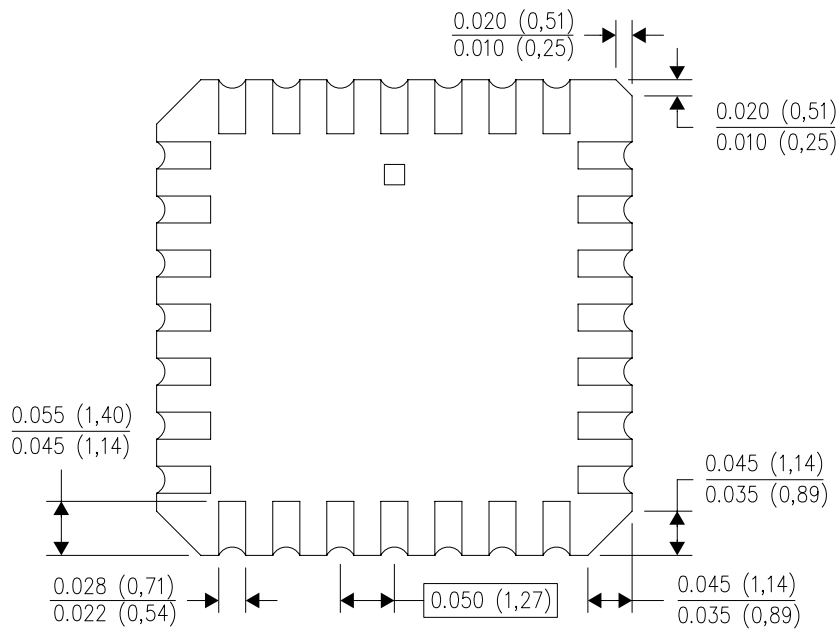

4040140/D 01/11

- NOTES:
- A. All linear dimensions are in inches (millimeters).
  - B. This drawing is subject to change without notice.
  - C. This package can be hermetically sealed with a metal lid.
  - D. Falls within JEDEC MS-004

**MECHANICAL DATA**

**N (R-PDIP-T\*\*)**

16 PINS SHOWN

**PLASTIC DUAL-IN-LINE PACKAGE**

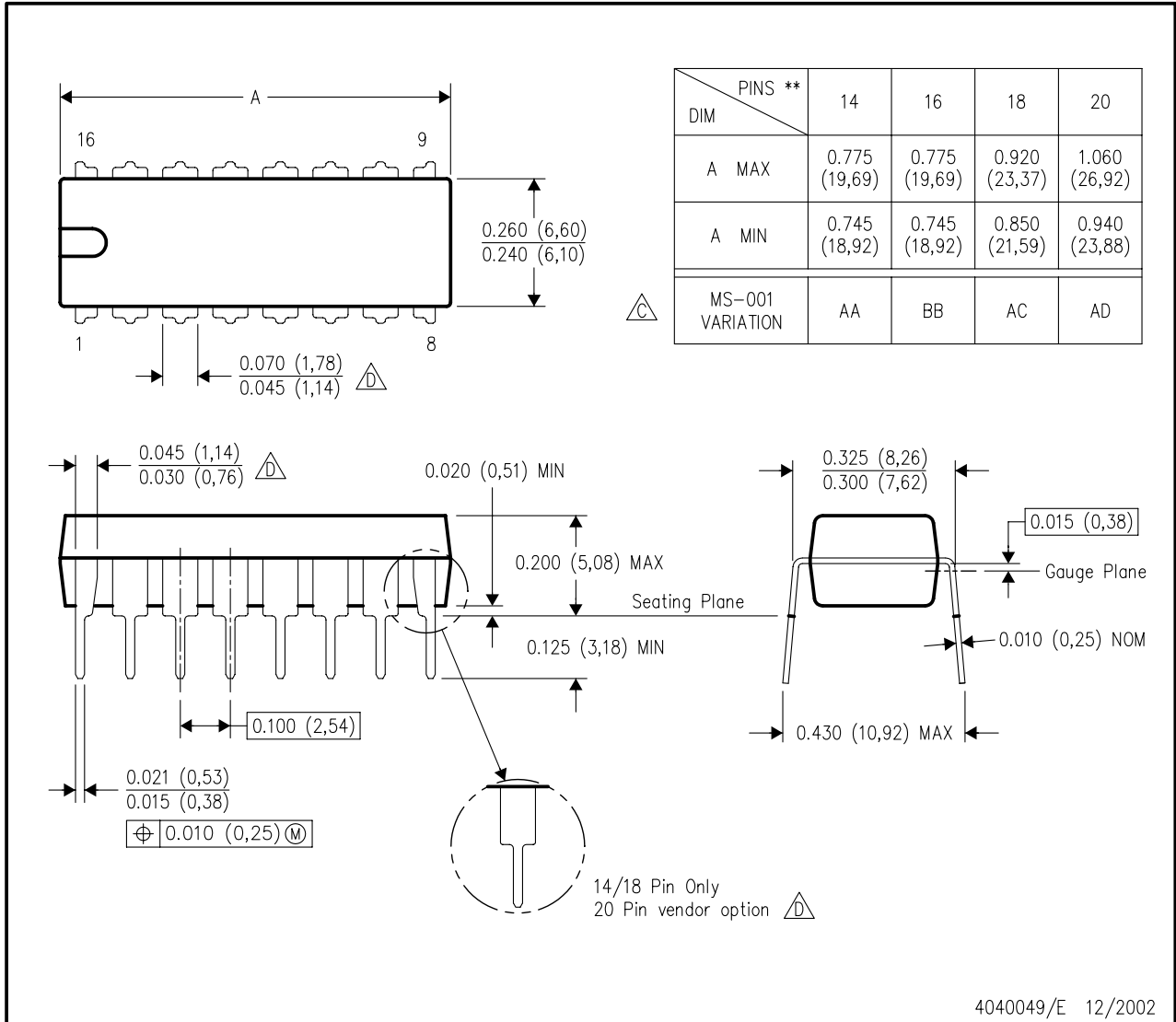

4040049/E 12/2002

- NOTES:
- A. All linear dimensions are in inches (millimeters).
  - B. This drawing is subject to change without notice.
  - Falls within JEDEC MS-001, except 18 and 20 pin minimum body length (Dim A).
  - The 20 pin end lead shoulder width is a vendor option, either half or full width.

**MECHANICAL DATA**

D (R-PDSO-G14)

PLASTIC SMALL OUTLINE

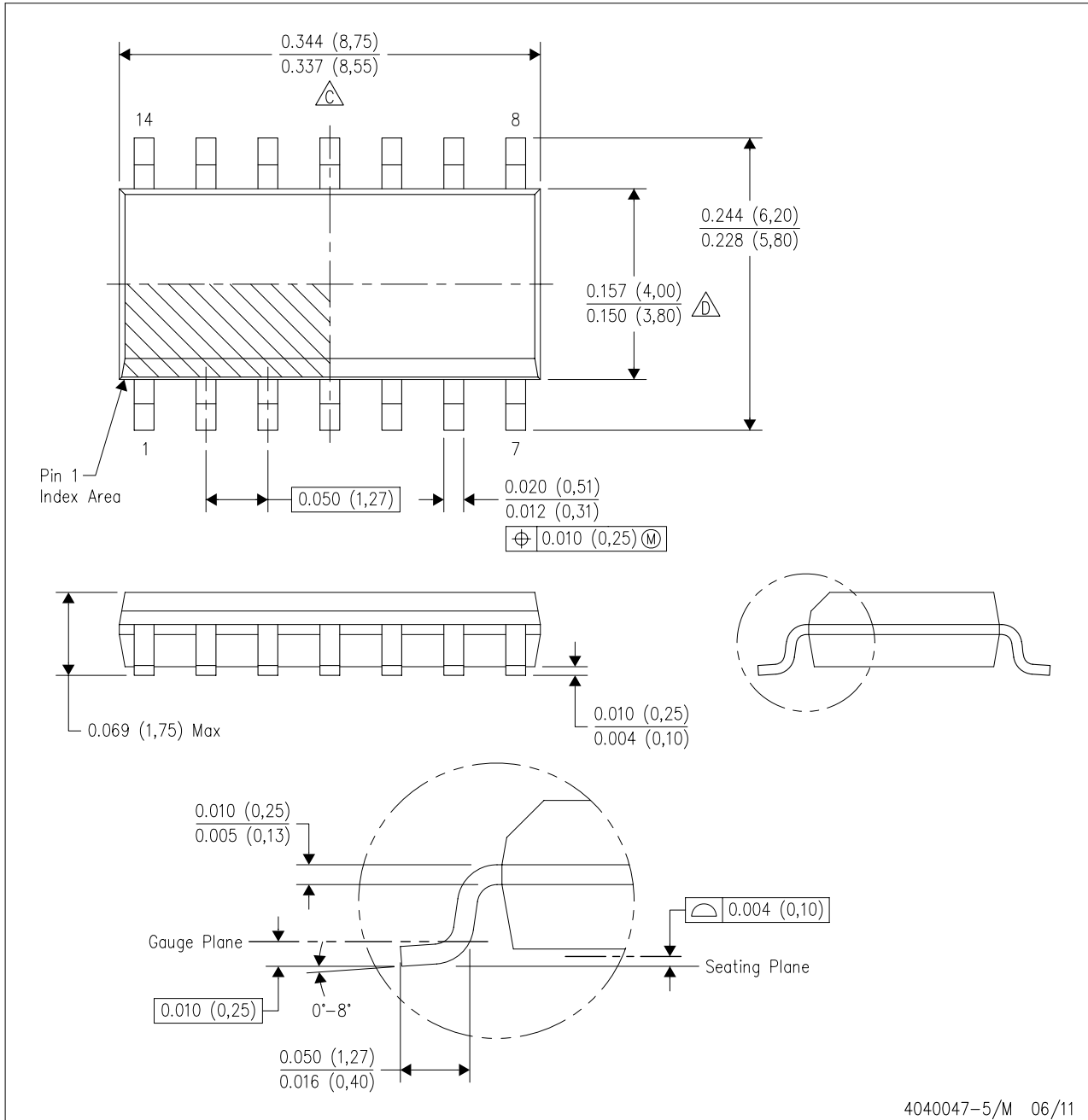

- NOTES:
- A. All linear dimensions are in inches (millimeters).
  - B. This drawing is subject to change without notice.
  - C. Body length does not include mold flash, protrusions, or gate burrs. Mold flash, protrusions, or gate burrs shall not exceed 0.006 (0,15) each side.
  - D. Body width does not include interlead flash. Interlead flash shall not exceed 0.017 (0,43) each side.
  - E. Reference JEDEC MS-012 variation AB.

**LAND PATTERN DATA**

D (R-PDSO-G14)

PLASTIC SMALL OUTLINE

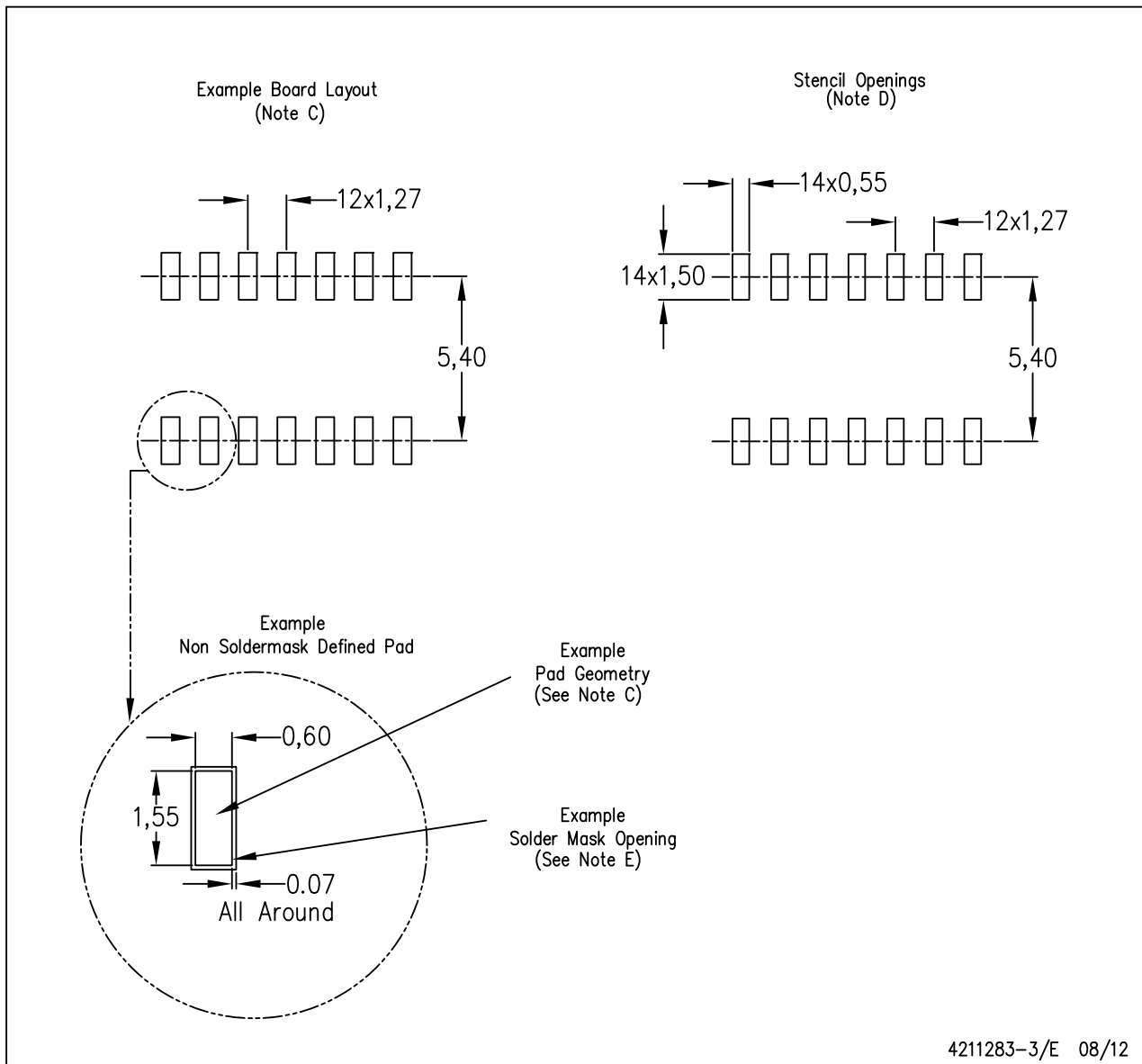

4211283-3/E 08/12

- NOTES:
- All linear dimensions are in millimeters.
  - This drawing is subject to change without notice.
  - Publication IPC-7351 is recommended for alternate designs.
  - Laser cutting apertures with trapezoidal walls and also rounding corners will offer better paste release. Customers should contact their board assembly site for stencil design recommendations. Refer to IPC-7525 for other stencil recommendations.
  - Customers should contact their board fabrication site for solder mask tolerances between and around signal pads.



**MECHANICAL DATA**

**NS (R-PDSO-G\*\*)**

**PLASTIC SMALL-OUTLINE PACKAGE**

**14-PINS SHOWN**

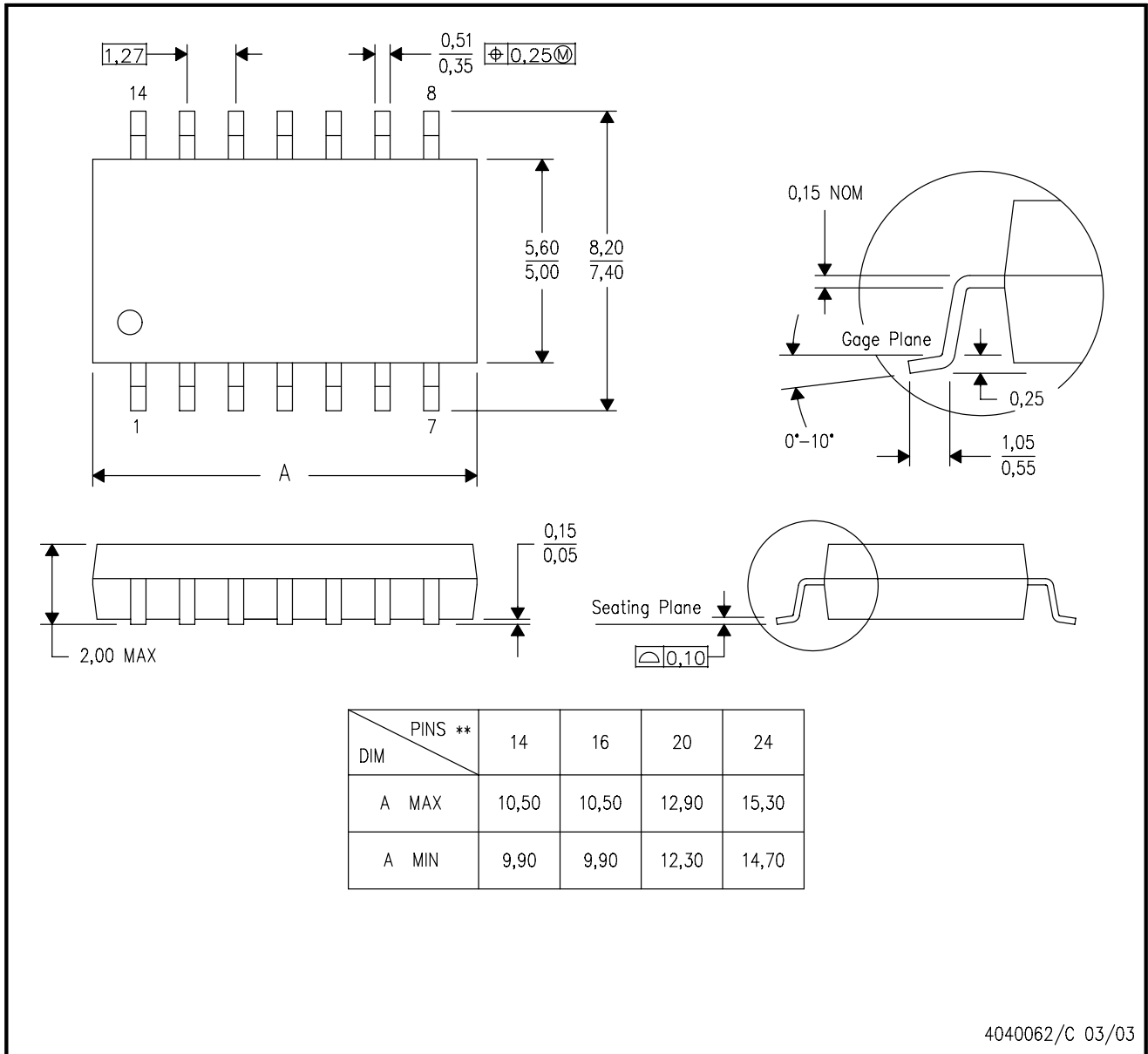

- NOTES:
- A. All linear dimensions are in millimeters.
  - B. This drawing is subject to change without notice.
  - C. Body dimensions do not include mold flash or protrusion, not to exceed 0,15.

### IMPORTANT NOTICE

Texas Instruments Incorporated and its subsidiaries (TI) reserve the right to make corrections, enhancements, improvements and other changes to its semiconductor products and services per JESD46, latest issue, and to discontinue any product or service per JESD48, latest issue. Buyers should obtain the latest relevant information before placing orders and should verify that such information is current and complete. All semiconductor products (also referred to herein as "components") are sold subject to TI's terms and conditions of sale supplied at the time of order acknowledgment.

TI warrants performance of its components to the specifications applicable at the time of sale, in accordance with the warranty in TI's terms and conditions of sale of semiconductor products. Testing and other quality control techniques are used to the extent TI deems necessary to support this warranty. Except where mandated by applicable law, testing of all parameters of each component is not necessarily performed.

TI assumes no liability for applications assistance or the design of Buyers' products. Buyers are responsible for their products and applications using TI components. To minimize the risks associated with Buyers' products and applications, Buyers should provide adequate design and operating safeguards.

TI does not warrant or represent that any license, either express or implied, is granted under any patent right, copyright, mask work right, or other intellectual property right relating to any combination, machine, or process in which TI components or services are used. Information published by TI regarding third-party products or services does not constitute a license to use such products or services or a warranty or endorsement thereof. Use of such information may require a license from a third party under the patents or other intellectual property of the third party, or a license from TI under the patents or other intellectual property of TI.

Reproduction of significant portions of TI information in TI data books or data sheets is permissible only if reproduction is without alteration and is accompanied by all associated warranties, conditions, limitations, and notices. TI is not responsible or liable for such altered documentation. Information of third parties may be subject to additional restrictions.

Resale of TI components or services with statements different from or beyond the parameters stated by TI for that component or service voids all express and any implied warranties for the associated TI component or service and is an unfair and deceptive business practice. TI is not responsible or liable for any such statements.

Buyer acknowledges and agrees that it is solely responsible for compliance with all legal, regulatory and safety-related requirements concerning its products, and any use of TI components in its applications, notwithstanding any applications-related information or support that may be provided by TI. Buyer represents and agrees that it has all the necessary expertise to create and implement safeguards which anticipate dangerous consequences of failures, monitor failures and their consequences, lessen the likelihood of failures that might cause harm and take appropriate remedial actions. Buyer will fully indemnify TI and its representatives against any damages arising out of the use of any TI components in safety-critical applications.

In some cases, TI components may be promoted specifically to facilitate safety-related applications. With such components, TI's goal is to help enable customers to design and create their own end-product solutions that meet applicable functional safety standards and requirements. Nonetheless, such components are subject to these terms.

No TI components are authorized for use in FDA Class III (or similar life-critical medical equipment) unless authorized officers of the parties have executed a special agreement specifically governing such use.

Only those TI components which TI has specifically designated as military grade or "enhanced plastic" are designed and intended for use in military/aerospace applications or environments. Buyer acknowledges and agrees that any military or aerospace use of TI components which have **not** been so designated is solely at the Buyer's risk, and that Buyer is solely responsible for compliance with all legal and regulatory requirements in connection with such use.

TI has specifically designated certain components as meeting ISO/TS16949 requirements, mainly for automotive use. In any case of use of non-designated products, TI will not be responsible for any failure to meet ISO/TS16949.

#### Products

Audio	<a href="http://www.ti.com/audio">www.ti.com/audio</a>
Amplifiers	<a href="http://amplifier.ti.com">amplifier.ti.com</a>
Data Converters	<a href="http://dataconverter.ti.com">dataconverter.ti.com</a>
DLP® Products	<a href="http://www.dlp.com">www.dlp.com</a>
DSP	<a href="http://dsp.ti.com">dsp.ti.com</a>
Clocks and Timers	<a href="http://www.ti.com/clocks">www.ti.com/clocks</a>
Interface	<a href="http://interface.ti.com">interface.ti.com</a>
Logic	<a href="http://logic.ti.com">logic.ti.com</a>
Power Mgmt	<a href="http://power.ti.com">power.ti.com</a>
Microcontrollers	<a href="http://microcontroller.ti.com">microcontroller.ti.com</a>
RFID	<a href="http://www.ti-rfid.com">www.ti-rfid.com</a>
OMAP Applications Processors	<a href="http://www.ti.com/omap">www.ti.com/omap</a>
Wireless Connectivity	<a href="http://www.ti.com/wirelessconnectivity">www.ti.com/wirelessconnectivity</a>

#### Applications

Automotive and Transportation	<a href="http://www.ti.com/automotive">www.ti.com/automotive</a>
Communications and Telecom	<a href="http://www.ti.com/communications">www.ti.com/communications</a>
Computers and Peripherals	<a href="http://www.ti.com/computers">www.ti.com/computers</a>
Consumer Electronics	<a href="http://www.ti.com/consumer-apps">www.ti.com/consumer-apps</a>
Energy and Lighting	<a href="http://www.ti.com/energy">www.ti.com/energy</a>
Industrial	<a href="http://www.ti.com/industrial">www.ti.com/industrial</a>
Medical	<a href="http://www.ti.com/medical">www.ti.com/medical</a>
Security	<a href="http://www.ti.com/security">www.ti.com/security</a>
Space, Avionics and Defense	<a href="http://www.ti.com/space-avionics-defense">www.ti.com/space-avionics-defense</a>
Video and Imaging	<a href="http://www.ti.com/video">www.ti.com/video</a>

#### TI E2E Community

[e2e.ti.com](http://e2e.ti.com)