

## Excellent Integrated System Limited

Stocking Distributor

Click to view price, real time Inventory, Delivery & Lifecycle Information:

[Texas Instruments](#)  
[CDC2351DBR](#)

For any questions, you can email us directly:

[sales@integrated-circuit.com](mailto:sales@integrated-circuit.com)

- Low Output Skew, Low Pulse Skew for Clock-Distribution and Clock-Generation Applications
- Operates at 3.3-V  $V_{CC}$
- LVTTTL-Compatible Inputs and Outputs
- Supports Mixed-Mode Signal Operation (5-V Input and Output Voltages With 3.3-V  $V_{CC}$ )
- Distributes One Clock Input to Ten Outputs
- Outputs Have Internal Series Damping Resistor to Reduce Transmission Line Effects
- Distributed  $V_{CC}$  and Ground Pins Reduce Switching Noise
- State-of-the-Art EPIC-II B™ BiCMOS Design Significantly Reduces Power Dissipation
- Package Options Include Plastic Small-Outline (DW) and Shrink Small-Outline (DB) Packages
- Available in Q-Temp Automotive High Reliability Automotive Applications Configuration Control / Print Support Qualification to Automotive Standards

DB OR DW PACKAGE  
(TOP VIEW)

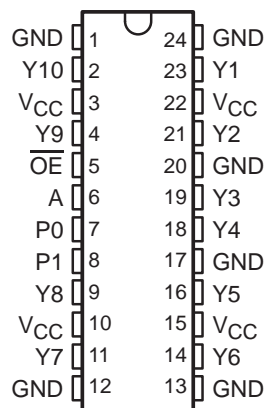

## description

The CDC2351 is a high-performance clock-driver circuit that distributes one input (A) to ten outputs (Y) with minimum skew for clock distribution. The output-enable ( $\overline{OE}$ ) input disables the outputs to a high-impedance state. Each output has an internal series damping resistor to improve signal integrity at the load. The CDC2351 operates at nominal 3.3-V  $V_{CC}$ .

The propagation delays are adjusted at the factory using the P0 and P1 pins. The factory adjustments ensure that the part-to-part skew is minimized and is kept within a specified window. Pins P0 and P1 are not intended for customer use and should be connected to GND.

The CDC2351 is characterized for operation from 0°C to 70°C. The CDC2351Q is characterized for operation over the full automotive temperature range of -40°C to 125°C.

FUNCTION TABLE

| INPUTS |                 | OUTPUTS |
|--------|-----------------|---------|
| A      | $\overline{OE}$ | In      |
| L      | H               | Z       |
| H      | H               | Z       |
| L      | L               | L       |
| H      | L               | H       |



Please be aware that an important notice concerning availability, standard warranty, and use in critical applications of Texas Instruments semiconductor products and disclaimers thereto appears at the end of this data sheet.

EPIC-II B is a trademark of Texas Instruments.

PRODUCTION DATA information is current as of publication date. Products conform to specifications per the terms of Texas Instruments standard warranty. Production processing does not necessarily include testing of all parameters.

Copyright © 2000, Texas Instruments Incorporated



POST OFFICE BOX 655303 • DALLAS, TEXAS 75265

**CDC2351**  
**1-LINE TO 10-LINE CLOCK DRIVER**  
**WITH 3-STATE OUTPUTS**

SCAS442D – FEBRUARY 1994 – REVISED SEPTEMBER 2000

**logic symbol†**

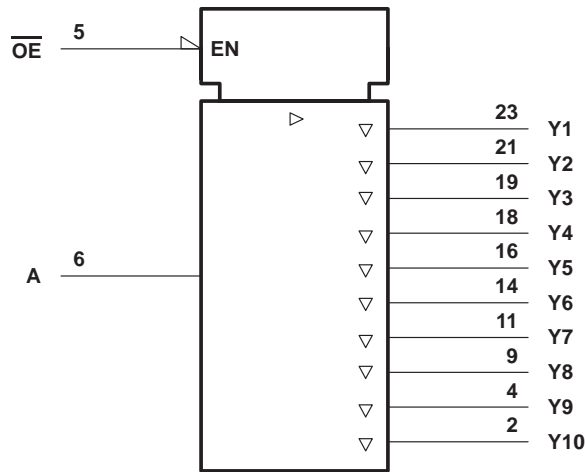

† This symbol is in accordance with ANSI/IEEE Std 91-1984 and IEC Publication 617-12.

**logic diagram (positive logic)**

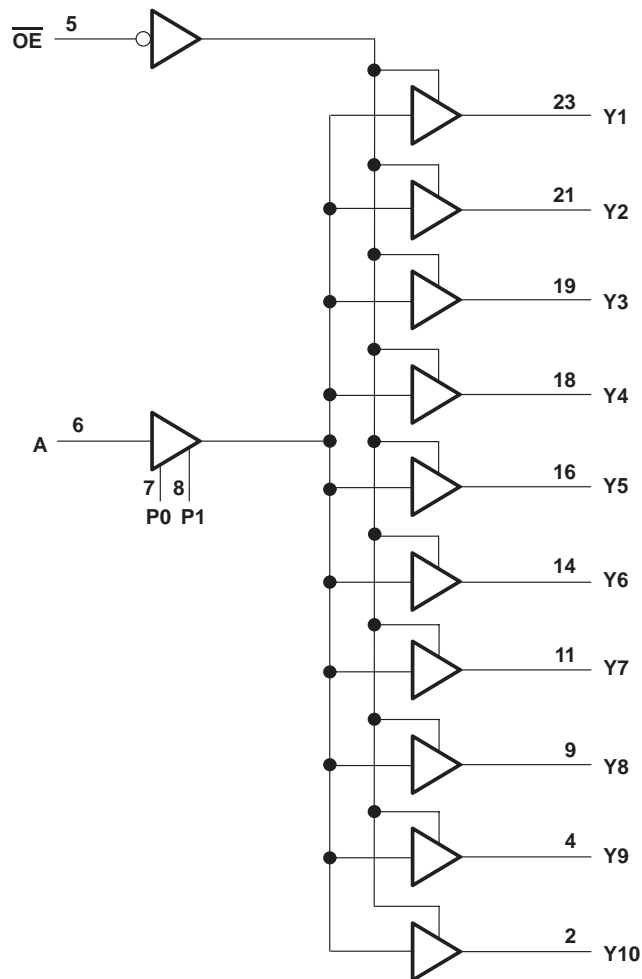

**CDC2351**  
**1-LINE TO 10-LINE CLOCK DRIVER**  
**WITH 3-STATE OUTPUTS**

SCAS442D – FEBRUARY 1994 – REVISED SEPTEMBER 2000

**absolute maximum ratings over operating free-air temperature range (unless otherwise noted)†**

|   |                 |
|---|-----------------|
| Supply voltage range, $V_{CC}$ .....  | -0.5 V to 4.6 V |
| Input voltage range, $V_I$ (see Note 1) .....   | -0.5 V to 7 V   |
| Voltage range applied to any output in the high state or power-off state,<br>$V_O$ (see Note 1) ..... | -0.5 V to 3.6 V |
| Current into any output in the low state, $I_O$ .....   | 24 mA           |
| Input clamp current, $I_{IK}$ ( $V_I < 0$ ) .....   | -18 mA          |
| Output clamp current, $I_{OK}$ ( $V_I < 0$ ) .....  | -50 mA          |
| Maximum power dissipation at $T_A = 55^\circ\text{C}$ (in still air) (see Note 2): DB package .....   | 0.65 W          |
| DW package .....  | 1.7 W           |
| Storage temperature range, $T_{stg}$ .....  | -65°C to 150°C  |

† Stresses beyond those listed under "absolute maximum ratings" may cause permanent damage to the device. These are stress ratings only, and functional operation of the device at these or any other conditions beyond those indicated under "recommended operating conditions" is not implied. Exposure to absolute-maximum-rated conditions for extended periods may affect device reliability.

- NOTES: 1. The input and output negative-voltage ratings may be exceeded if the input and output clamp-current ratings are observed.  
 2. The maximum package power dissipation is calculated using a junction temperature of 150°C and a board trace length of 750 mils. For more information, refer to the *Package Thermal Considerations* application note in the 1994 *ABT Advanced BiCMOS Technology Data Book*, literature number SCBD002B.

**recommended operating conditions (see Note 3)**

|             |                                | MIN      | MAX | UNIT |    |
|-------------|--------------------------------|----------|-----|------|----|
| $V_{CC}$    | Supply voltage                 | 3        | 3.6 | V    |    |
| $V_{IH}$    | High-level input voltage       | 2        |     | V    |    |
| $V_{IL}$    | Low-level input voltage        |          | 0.8 | V    |    |
| $V_I$       | Input voltage                  | 0        | 5.5 | V    |    |
| $I_{OH}$    | High-level output current      |          | -12 | mA   |    |
| $I_{OL}$    | Low-level output current       |          | 12  | mA   |    |
| $f_{clock}$ | Input clock frequency          |          | 100 | MHz  |    |
| $T_A$       | Operating free-air temperature | CDC2351  | 0   | 70   | °C |
|             |                                | CDC2351Q | -40 | 125  |    |

NOTE 3: Unused pins (input or I/O) must be held high or low.

**electrical characteristics over recommended operating free-air temperature range (unless otherwise noted)**

| PARAMETER       | TEST CONDITIONS           |                                   | MIN              | TYP | MAX      | UNIT          |
|-----------------|---------------------------|-----------------------------------|------------------|-----|----------|---------------|
| $V_{IK}$        | $V_{CC} = 3\text{ V}$ ,   | $I_I = -18\text{ mA}$             |                  |     | -1.2     | V             |
| $V_{OH}$        | $V_{CC} = 3\text{ V}$ ,   | $I_{OH} = -12\text{ mA}$          | 2                |     |          | V             |
| $V_{OL}$        | $V_{CC} = 3\text{ V}$ ,   | $I_{OL} = 12\text{ mA}$           |                  |     | 0.8      | V             |
| $I_I$           | $V_{CC} = 3.6\text{ V}$ , | $V_I = V_{CC}$ or GND             |                  |     | $\pm 1$  | $\mu\text{A}$ |
| $I_{O\ddagger}$ | $V_{CC} = 3.6\text{ V}$ , | $V_O = 2.5\text{ V}$              | -7               |     | -70      | mA            |
| $I_{OZ}$        | $V_{CC} = 3.6\text{ V}$ , | $V_{CC} = 3\text{ V}$ or 0        |                  |     | $\pm 10$ | $\mu\text{A}$ |
| $I_{CC}$        | $V_{CC} = 3.6\text{ V}$ , | $I_O = 0$ , $V_I = V_{CC}$ or GND | Outputs high     |     | 0.3      | mA            |
|                 |                           |                                   | Outputs low      |     | 15       |               |
|                 |                           |                                   | Outputs disabled |     | 0.3      |               |
| $C_i$           | $V_I = V_{CC}$ or GND,    | $V_{CC} = 3.3\text{ V}$ ,         |                  |     | 4        | pF            |
| $C_o$           | $V_O = V_{CC}$ or GND,    | $V_{CC} = 3.3\text{ V}$ ,         |                  |     | 6        | pF            |

‡ Not more than one output should be tested at a time, and the duration of the test should not exceed one second.

**CDC2351**
**1-LINE TO 10-LINE CLOCK DRIVER  
WITH 3-STATE OUTPUTS**

SCAS442D – FEBRUARY 1994 – REVISED SEPTEMBER 2000

**switching characteristics,  $C_L = 50$  pF (see Figures 1 and 2)**

| PARAMETER    | FROM (INPUT)    | TO (OUTPUT) | CDC2351                              |     |     | CDC2351Q   |      | CDC2351   |     | UNIT |
|--------------|-----------------|-------------|--------------------------------------|-----|-----|--|------|---|-----|------|
|              |                 |             | $V_{CC} = 3.3$ V, $T_A = 25^\circ$ C |     |     | $V_{CC} = 3$ V to 3.6 V, $T_A = -40^\circ$ C to 125° C |      | $V_{CC} = 3$ V to 3.6 V, $T_A = 0^\circ$ C to 70° C |     |      |
|              |                 |             | MIN                                  | TYP | MAX | MIN  | MAX  | MIN   | MAX |      |
| $t_{PLH}$    | A               | Y           | 3.8                                  | 4.3 | 4.8 | 1.1  | 11   |   |     | ns   |
| $t_{PHL}$    |                 |             | 3.6                                  | 4.1 | 4.6 | 1  | 9.7  |   |     |      |
| $t_{PZH}$    | $\overline{OE}$ | Y           | 2.4                                  | 4.9 | 6.0 | 1  | 12   | 1.8   | 6.9 | ns   |
| $t_{PZL}$    |                 |             | 2.4                                  | 4.3 | 6.0 | 1  | 11.1 | 1.8   | 6.9 |      |
| $t_{PHZ}$    | $\overline{OE}$ | Y           | 2.2                                  | 4.4 | 6.3 | 1  | 11.1 | 2.1   | 7.1 | ns   |
| $t_{PLZ}$    |                 |             | 2.2                                  | 4.6 | 6.3 | 1  | 11.5 | 2.1   | 7.3 |      |
| $t_{sk(o)}$  | A               | Y           |                                      | 0.3 | 0.5 |  | 2.5  |   | 0.5 | ns   |
| $t_{sk(p)}$  | A               | Y           |                                      | 0.2 | 0.8 |  | 3    |   | 0.8 | ns   |
| $t_{sk(pr)}$ | A               | Y           |                                      |     | 1   |  |      |   | 1   | ns   |
| $t_r$        | A               | Y           |                                      |     |     |  | 2.5  |   | 2.5 | ns   |
| $t_f$        | A               | Y           |                                      |     |     |  | 2.5  |   | 2.5 | ns   |

**switching characteristics temperature and  $V_{CC}$  coefficients over recommended operating free-air temperature and  $V_{CC}$  range (see Note 4)**

| PARAMETER                |  | FROM (INPUT) | TO (OUTPUT) | MIN | MAX   | UNIT      |
|--------------------------|--|--------------|-------------|-----|-------|-----------|
| $\infty t_{PLH}(T)$      | Average temperature coefficient of low to high propagation delay | A            | Y           |     | 85†   | ps/10°C   |
| $\infty t_{PHL}(T)$      | Average temperature coefficient of high to low propagation delay | A            | Y           |     | 50†   | ps/10°C   |
| $\infty t_{PLH}(V_{CC})$ | Average $V_{CC}$ coefficient of low to high propagation delay    | A            | Y           |     | -145‡ | ps/100 mV |
| $\infty t_{PHL}(V_{CC})$ | Average $V_{CC}$ coefficient of high to low propagation delay    | A            | Y           |     | -100‡ | ps/100 mV |

 †  $\infty t_{PLH}(T)$  and  $\infty t_{PHL}(T)$  are virtually independent of  $V_{CC}$ .

 ‡  $\infty t_{PLH}(V_{CC})$  and  $\infty t_{PHL}(V_{CC})$  are virtually independent of temperature.

NOTE 4: This data was extracted from characterization material and are not tested at the factory.

**PARAMETER MEASUREMENT INFORMATION**

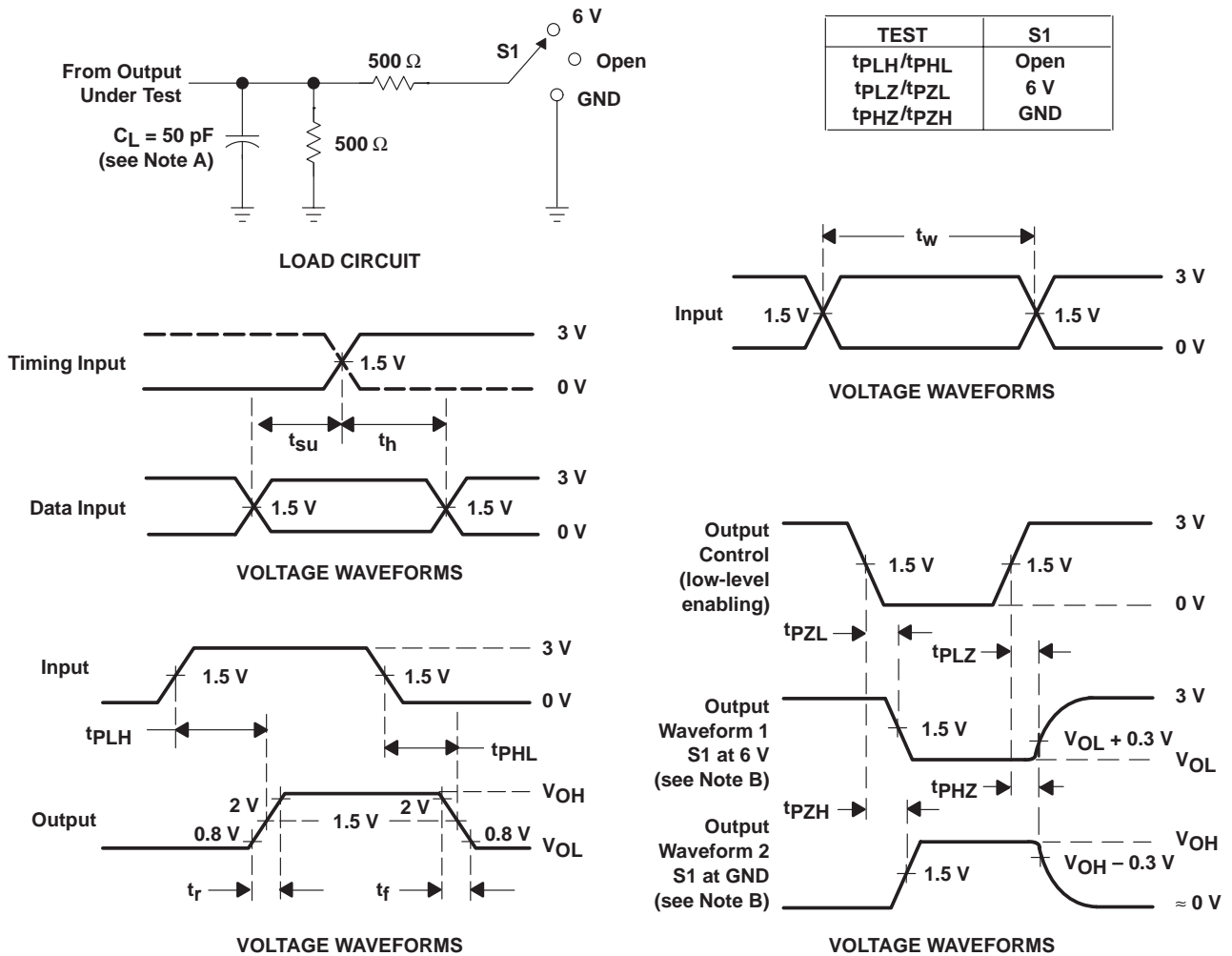

- NOTES: A. C<sub>L</sub> includes probe and jig capacitance.  
 B. Waveform 1 is for an output with internal conditions such that the output is low except when disabled by the output control. Waveform 2 is for an output with internal conditions such that the output is high except when disabled by the output control.  
 C. All input pulses are supplied by generators having the following characteristics: PRR ≤ 10 MHz, Z<sub>O</sub> = 50 Ω, t<sub>r</sub> ≤ 2.5 ns, t<sub>f</sub> ≤ 2.5 ns.  
 D. The outputs are measured one at a time with one transition per measurement.

**Figure 1. Load Circuit and Voltage Waveforms**

**CDC2351**  
**1-LINE TO 10-LINE CLOCK DRIVER**  
**WITH 3-STATE OUTPUTS**

SCAS442D – FEBRUARY 1994 – REVISED SEPTEMBER 2000

**PARAMETER MEASUREMENT INFORMATION**

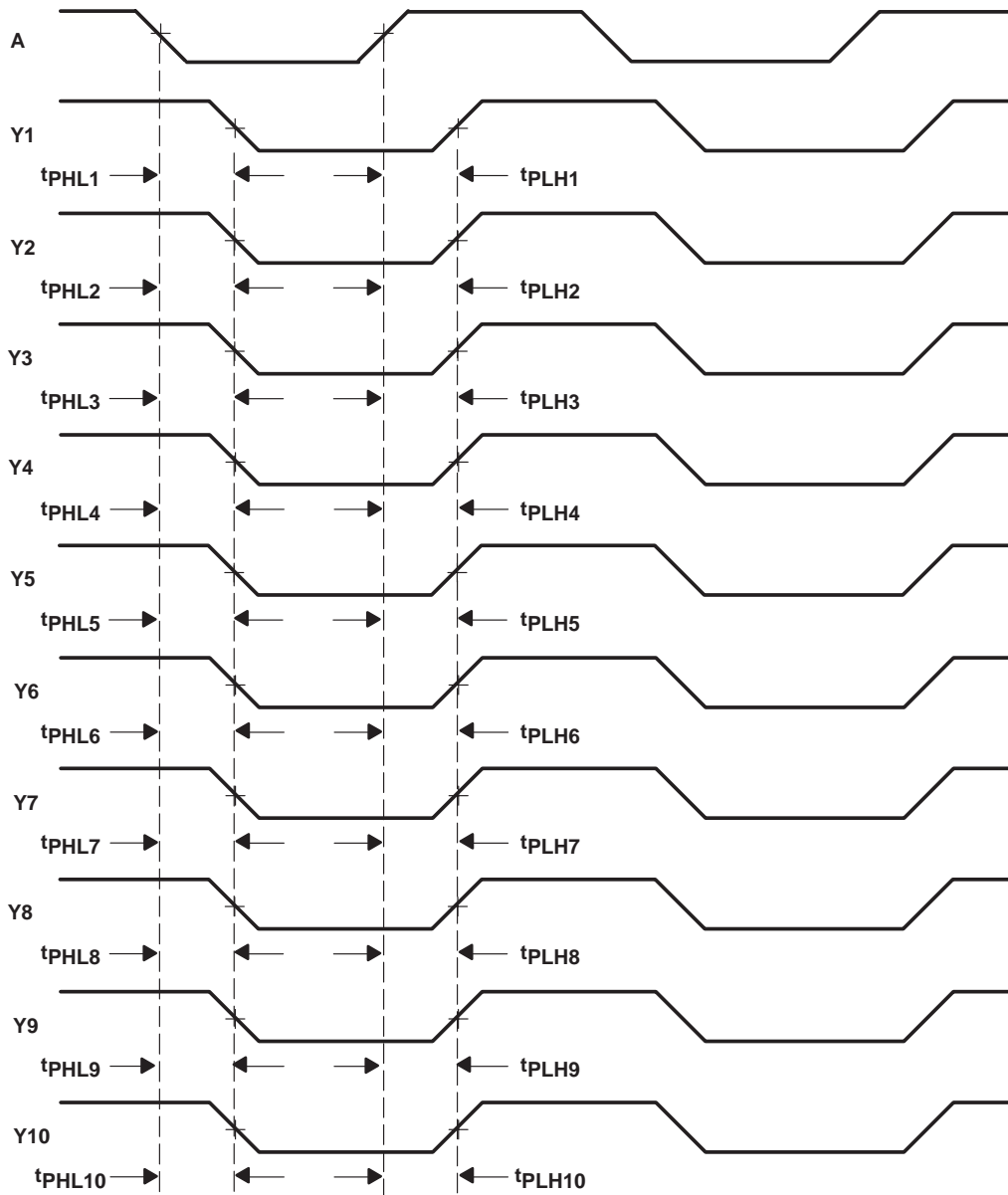

- NOTES: A. Output skew,  $t_{sk(o)}$ , is calculated as the greater of:
- The difference between the fastest and slowest of  $t_{PLHn}$  ( $n = 1, 2, 3, 4, 5, 6, 7, 8, 9, 10$ )
  - The difference between the fastest and slowest of  $t_{PHLn}$  ( $n = 1, 2, 3, 4, 5, 6, 7, 8, 9, 10$ )
- B. Pulse skew,  $t_{sk(p)}$ , is calculated as the greater of  $|t_{PLHn} - t_{PHLn}|$  ( $n = 1, 2, 3, 4, 5, 6, 7, 8, 9, 10$ ).
- C. Process skew,  $t_{sk(pr)}$ , is calculated as the greater of:
- The difference between the fastest and slowest of  $t_{PLHn}$  ( $n = 1, 2, 3, 4, 5, 6, 7, 8, 9, 10$ ) across multiple devices under identical operating conditions
  - The difference between the fastest and slowest of  $t_{PHLn}$  ( $n = 1, 2, 3, 4, 5, 6, 7, 8, 9, 10$ ) across multiple devices under identical operating conditions

**Figure 2. Waveforms for Calculation of  $t_{sk(o)}$ ,  $t_{sk(p)}$ ,  $t_{sk(pr)}$**

**PACKAGING INFORMATION**

| Orderable Device | Status<br>(1) | Package Type | Package Drawing | Pins | Package Qty | Eco Plan<br>(2)         | Lead/Ball Finish | MSL Peak Temp<br>(3) | Op Temp (°C) | Top-Side Markings<br>(4) | Samples                 |
|------------------|---------------|--------------|-----------------|------|-------------|-------------------------|------------------|----------------------|--------------|--------------------------|-------------------------|
| CDC2351DB        | ACTIVE        | SSOP         | DB              | 24   | 60          | Green (RoHS & no Sb/Br) | CU NIPDAU        | Level-1-260C-UNLIM   | 0 to 70      | CK2351                   | <a href="#">Samples</a> |
| CDC2351DBG4      | ACTIVE        | SSOP         | DB              | 24   | 60          | Green (RoHS & no Sb/Br) | CU NIPDAU        | Level-1-260C-UNLIM   | 0 to 70      | CK2351                   | <a href="#">Samples</a> |
| CDC2351DBLE      | OBSOLETE      | SSOP         | DB              | 24   |             | TBD                     | Call TI          | Call TI              | 0 to 70      |                          |                         |
| CDC2351DBR       | ACTIVE        | SSOP         | DB              | 24   | 2000        | Green (RoHS & no Sb/Br) | CU NIPDAU        | Level-1-260C-UNLIM   | 0 to 70      | CK2351                   | <a href="#">Samples</a> |
| CDC2351DBG4      | ACTIVE        | SSOP         | DB              | 24   | 2000        | Green (RoHS & no Sb/Br) | CU NIPDAU        | Level-1-260C-UNLIM   | 0 to 70      | CK2351                   | <a href="#">Samples</a> |
| CDC2351DW        | ACTIVE        | SOIC         | DW              | 24   | 25          | Green (RoHS & no Sb/Br) | CU NIPDAU        | Level-1-260C-UNLIM   | 0 to 70      | CDC2351                  | <a href="#">Samples</a> |
| CDC2351DWG4      | ACTIVE        | SOIC         | DW              | 24   | 25          | Green (RoHS & no Sb/Br) | CU NIPDAU        | Level-1-260C-UNLIM   | 0 to 70      | CDC2351                  | <a href="#">Samples</a> |
| CDC2351DWR       | ACTIVE        | SOIC         | DW              | 24   | 2000        | Green (RoHS & no Sb/Br) | CU NIPDAU        | Level-1-260C-UNLIM   | 0 to 70      | CDC2351                  | <a href="#">Samples</a> |
| CDC2351DWRG4     | ACTIVE        | SOIC         | DW              | 24   | 2000        | Green (RoHS & no Sb/Br) | CU NIPDAU        | Level-1-260C-UNLIM   | 0 to 70      | CDC2351                  | <a href="#">Samples</a> |
| CDC2351PWR       | OBSOLETE      | TSSOP        | PW              | 24   |             | TBD                     | Call TI          | Call TI              |              |                          |                         |
| CDC2351PWRG4     | OBSOLETE      | TSSOP        | PW              | 24   |             | TBD                     | Call TI          | Call TI              |              |                          |                         |
| CDC2351QDB       | ACTIVE        | SSOP         | DB              | 24   | 60          | Green (RoHS & no Sb/Br) | CU NIPDAU        | Level-1-260C-UNLIM   | -40 to 125   | CK2351Q                  | <a href="#">Samples</a> |
| CDC2351QDBG4     | ACTIVE        | SSOP         | DB              | 24   | 60          | Green (RoHS & no Sb/Br) | CU NIPDAU        | Level-1-260C-UNLIM   | -40 to 125   | CK2351Q                  | <a href="#">Samples</a> |
| CDC2351QDBR      | ACTIVE        | SSOP         | DB              | 24   | 2000        | Green (RoHS & no Sb/Br) | CU NIPDAU        | Level-1-260C-UNLIM   | -40 to 125   | CK2351Q                  | <a href="#">Samples</a> |
| CDC2351QDBG4     | ACTIVE        | SSOP         | DB              | 24   | 2000        | Green (RoHS & no Sb/Br) | CU NIPDAU        | Level-1-260C-UNLIM   | -40 to 125   | CK2351Q                  | <a href="#">Samples</a> |

(1) The marketing status values are defined as follows:

**ACTIVE:** Product device recommended for new designs.

**LIFEBUY:** TI has announced that the device will be discontinued, and a lifetime-buy period is in effect.

**NRND:** Not recommended for new designs. Device is in production to support existing customers, but TI does not recommend using this part in a new design.

**PREVIEW:** Device has been announced but is not in production. Samples may or may not be available.

**OBSOLETE:** TI has discontinued the production of the device.





<sup>(2)</sup> Eco Plan - The planned eco-friendly classification: Pb-Free (RoHS), Pb-Free (RoHS Exempt), or Green (RoHS & no Sb/Br) - please check <http://www.ti.com/productcontent> for the latest availability information and additional product content details.

**TBD:** The Pb-Free/Green conversion plan has not been defined.

**Pb-Free (RoHS):** TI's terms "Lead-Free" or "Pb-Free" mean semiconductor products that are compatible with the current RoHS requirements for all 6 substances, including the requirement that lead not exceed 0.1% by weight in homogeneous materials. Where designed to be soldered at high temperatures, TI Pb-Free products are suitable for use in specified lead-free processes.

**Pb-Free (RoHS Exempt):** This component has a RoHS exemption for either 1) lead-based flip-chip solder bumps used between the die and package, or 2) lead-based die adhesive used between the die and leadframe. The component is otherwise considered Pb-Free (RoHS compatible) as defined above.

**Green (RoHS & no Sb/Br):** TI defines "Green" to mean Pb-Free (RoHS compatible), and free of Bromine (Br) and Antimony (Sb) based flame retardants (Br or Sb do not exceed 0.1% by weight in homogeneous material)

<sup>(3)</sup> MSL, Peak Temp. -- The Moisture Sensitivity Level rating according to the JEDEC industry standard classifications, and peak solder temperature.

<sup>(4)</sup> Multiple Top-Side Markings will be inside parentheses. Only one Top-Side Marking contained in parentheses and separated by a "-" will appear on a device. If a line is indented then it is a continuation of the previous line and the two combined represent the entire Top-Side Marking for that device.

**Important Information and Disclaimer:** The information provided on this page represents TI's knowledge and belief as of the date that it is provided. TI bases its knowledge and belief on information provided by third parties, and makes no representation or warranty as to the accuracy of such information. Efforts are underway to better integrate information from third parties. TI has taken and continues to take reasonable steps to provide representative and accurate information but may not have conducted destructive testing or chemical analysis on incoming materials and chemicals. TI and TI suppliers consider certain information to be proprietary, and thus CAS numbers and other limited information may not be available for release.

In no event shall TI's liability arising out of such information exceed the total purchase price of the TI part(s) at issue in this document sold by TI to Customer on an annual basis.

**OTHER QUALIFIED VERSIONS OF CDC2351 :**

- Enhanced Product: [CDC2351-EP](#)

NOTE: Qualified Version Definitions:

- Enhanced Product - Supports Defense, Aerospace and Medical Applications

**TAPE AND REEL INFORMATION**

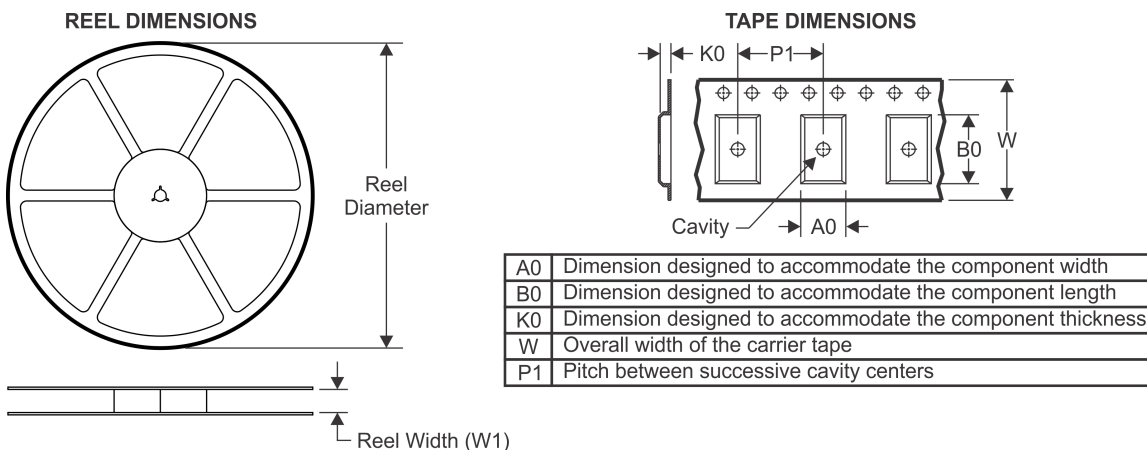

**QUADRANT ASSIGNMENTS FOR PIN 1 ORIENTATION IN TAPE**

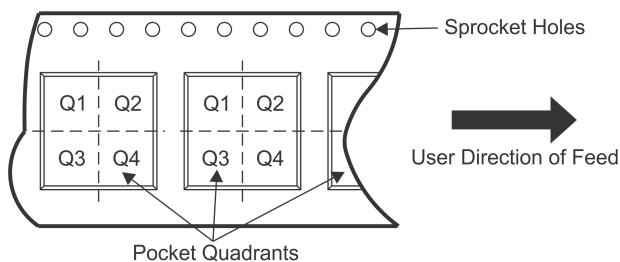

\*All dimensions are nominal

| Device        | Package Type | Package Drawing | Pins | SPQ  | Reel Diameter (mm) | Reel Width W1 (mm) | A0 (mm) | B0 (mm) | K0 (mm) | P1 (mm) | W (mm) | Pin1 Quadrant |
|---------------|--------------|-----------------|------|------|--------------------|--------------------|---------|---------|---------|---------|--------|---------------|
| CDC2351DBR    | SSOP         | DB              | 24   | 2000 | 330.0              | 16.4               | 8.2     | 8.8     | 2.5     | 12.0    | 16.0   | Q1            |
| CDC2351DWR    | SOIC         | DW              | 24   | 2000 | 330.0              | 24.4               | 10.75   | 15.7    | 2.7     | 12.0    | 24.0   | Q1            |
| CDC2351QDBR   | SSOP         | DB              | 24   | 2000 | 330.0              | 16.4               | 8.2     | 8.8     | 2.5     | 12.0    | 16.0   | Q1            |
| CDC2351QDBRG4 | SSOP         | DB              | 24   | 2000 | 330.0              | 16.4               | 8.2     | 8.8     | 2.5     | 12.0    | 16.0   | Q1            |

**TAPE AND REEL BOX DIMENSIONS**

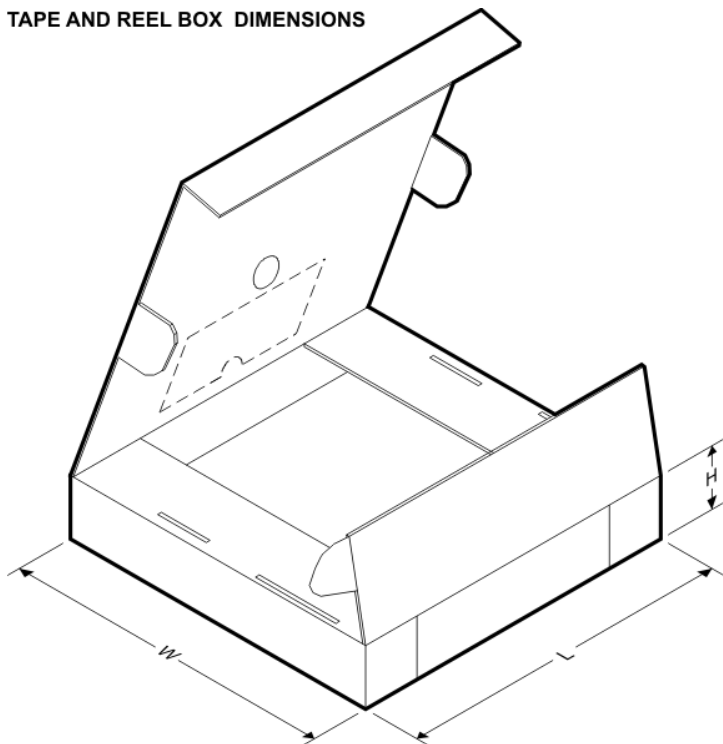

\*All dimensions are nominal

| Device        | Package Type | Package Drawing | Pins | SPQ  | Length (mm) | Width (mm) | Height (mm) |
|---------------|--------------|-----------------|------|------|-------------|------------|-------------|
| CDC2351DBR    | SSOP         | DB              | 24   | 2000 | 367.0       | 367.0      | 38.0        |
| CDC2351DWR    | SOIC         | DW              | 24   | 2000 | 367.0       | 367.0      | 45.0        |
| CDC2351QDBR   | SSOP         | DB              | 24   | 2000 | 367.0       | 367.0      | 38.0        |
| CDC2351QDBRG4 | SSOP         | DB              | 24   | 2000 | 367.0       | 367.0      | 38.0        |

**MECHANICAL DATA**

DW (R-PDSO-G24)

PLASTIC SMALL OUTLINE

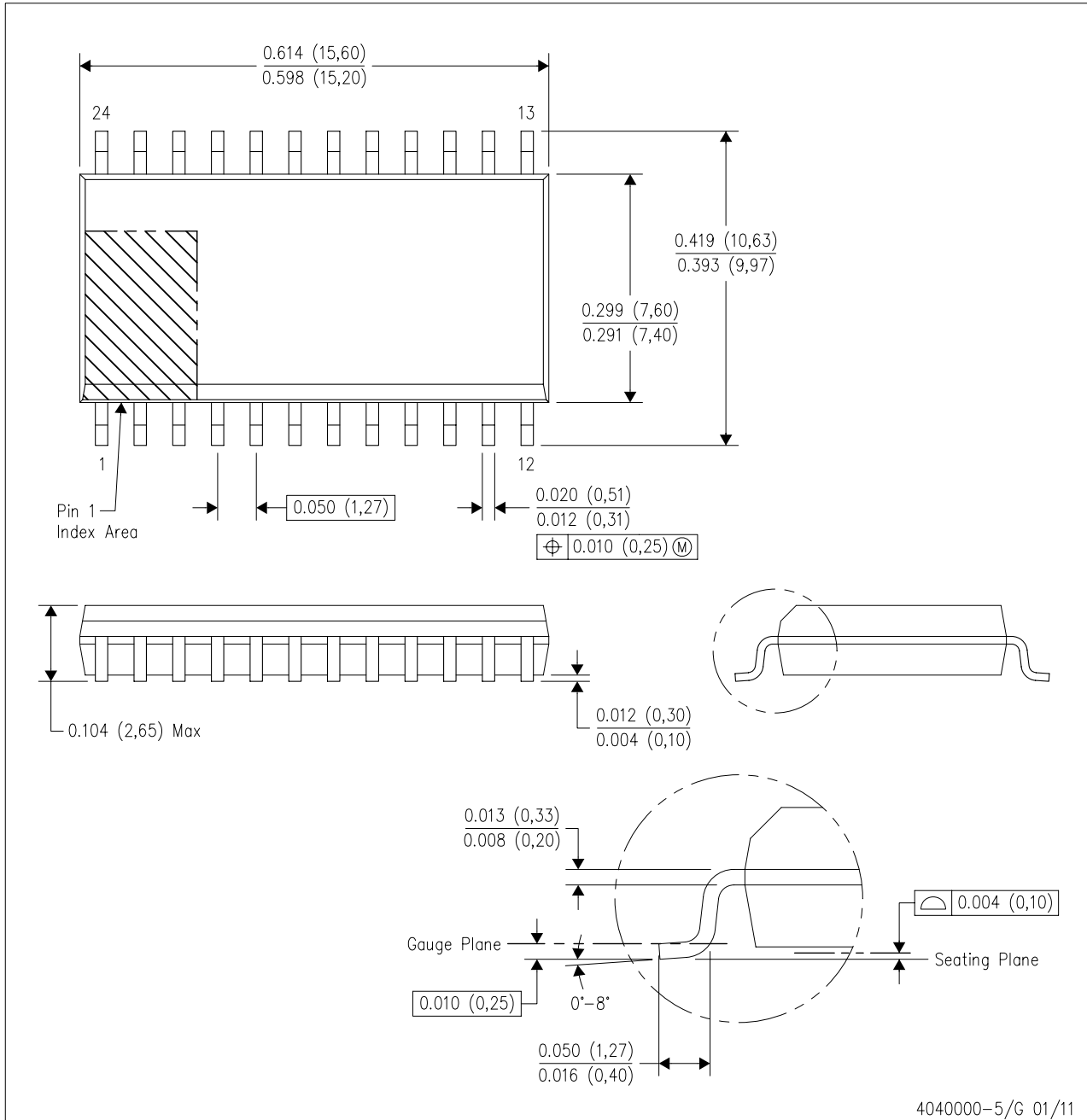

- NOTES:
- A. All linear dimensions are in inches (millimeters). Dimensioning and tolerancing per ASME Y14.5M-1994.
  - B. This drawing is subject to change without notice.
  - C. Body dimensions do not include mold flash or protrusion not to exceed 0.006 (0,15).
  - D. Falls within JEDEC MS-013 variation AD.

**MECHANICAL DATA**

PW (R-PDSO-G24)

PLASTIC SMALL OUTLINE

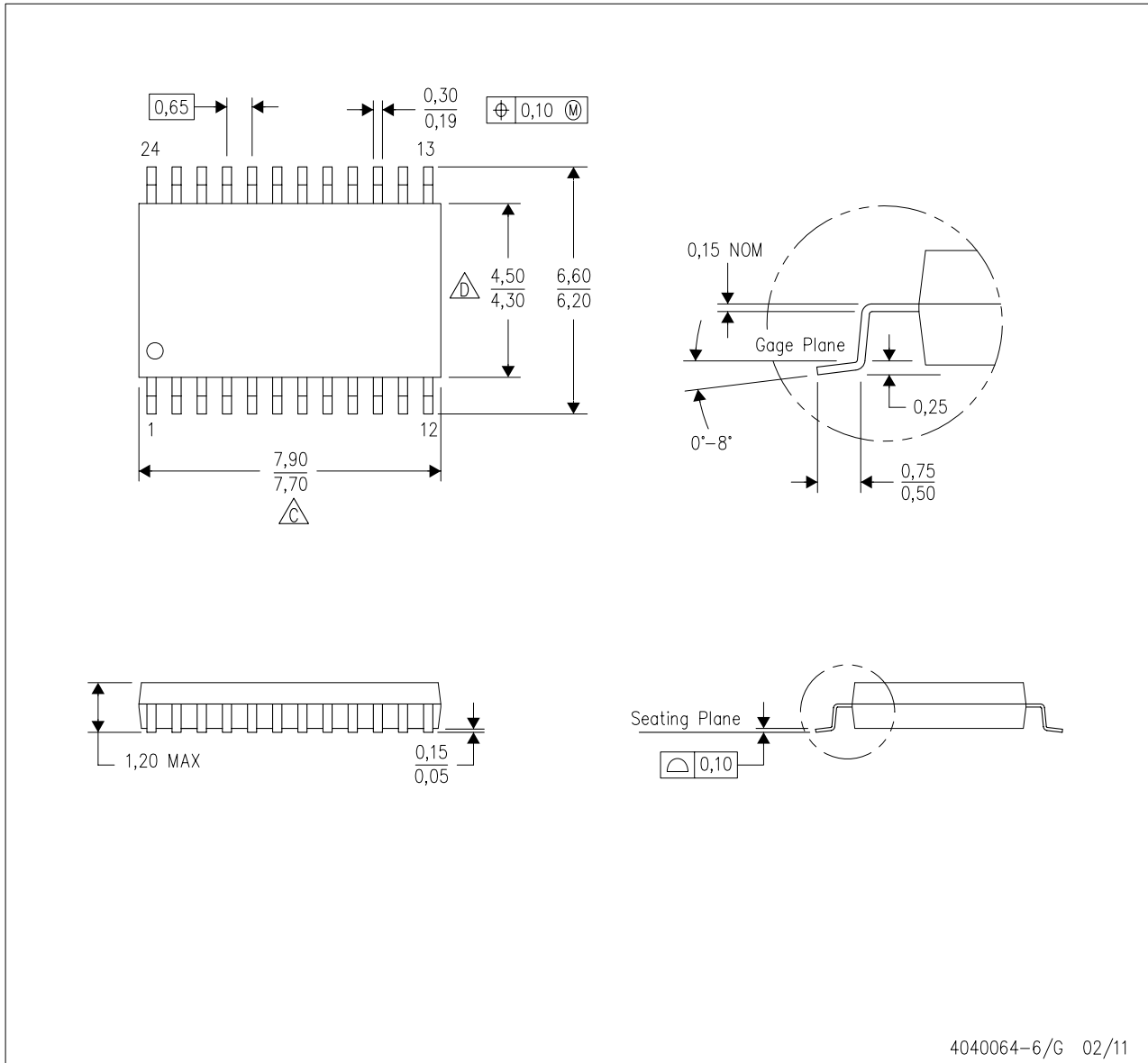

4040064-6/G 02/11

- NOTES:
- A. All linear dimensions are in millimeters. Dimensioning and tolerancing per ASME Y14.5M-1994.
  - B. This drawing is subject to change without notice.
  - Body length does not include mold flash, protrusions, or gate burrs. Mold flash, protrusions, or gate burrs shall not exceed 0,15 each side.
  - Body width does not include interlead flash. Interlead flash shall not exceed 0,25 each side.
  - E. Falls within JEDEC MO-153

MSS0002E - JANUARY 1995 - REVISED DECEMBER 2001

**DB (R-PDSO-G\*\*)**

**PLASTIC SMALL-OUTLINE**

28 PINS SHOWN

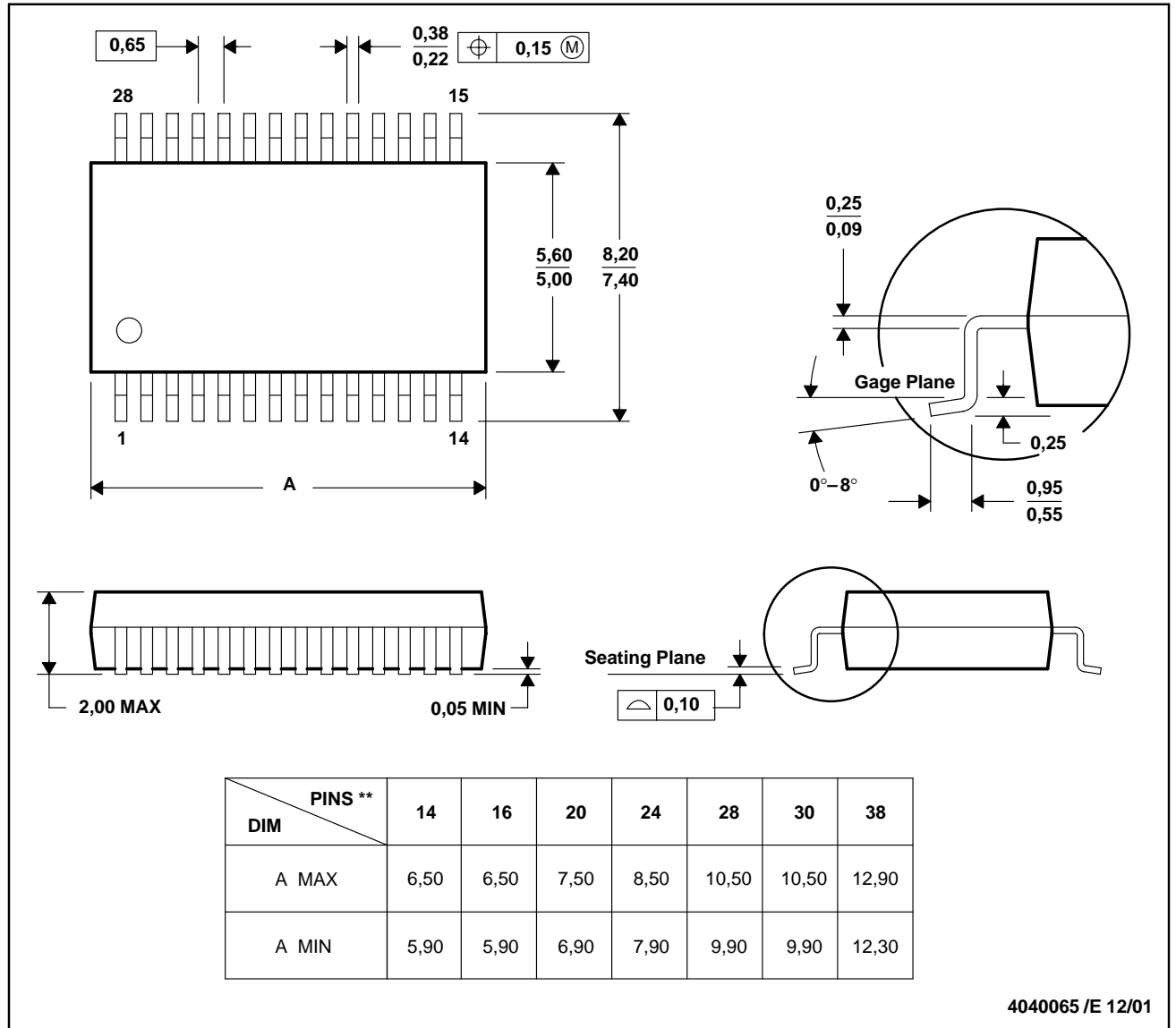

4040065 / E 12/01

- NOTES: A. All linear dimensions are in millimeters.  
 B. This drawing is subject to change without notice.  
 C. Body dimensions do not include mold flash or protrusion not to exceed 0,15.  
 D. Falls within JEDEC MO-150

## IMPORTANT NOTICE

Texas Instruments Incorporated and its subsidiaries (TI) reserve the right to make corrections, enhancements, improvements and other changes to its semiconductor products and services per JESD46, latest issue, and to discontinue any product or service per JESD48, latest issue. Buyers should obtain the latest relevant information before placing orders and should verify that such information is current and complete. All semiconductor products (also referred to herein as “components”) are sold subject to TI’s terms and conditions of sale supplied at the time of order acknowledgment.

TI warrants performance of its components to the specifications applicable at the time of sale, in accordance with the warranty in TI’s terms and conditions of sale of semiconductor products. Testing and other quality control techniques are used to the extent TI deems necessary to support this warranty. Except where mandated by applicable law, testing of all parameters of each component is not necessarily performed.

TI assumes no liability for applications assistance or the design of Buyers’ products. Buyers are responsible for their products and applications using TI components. To minimize the risks associated with Buyers’ products and applications, Buyers should provide adequate design and operating safeguards.

TI does not warrant or represent that any license, either express or implied, is granted under any patent right, copyright, mask work right, or other intellectual property right relating to any combination, machine, or process in which TI components or services are used. Information published by TI regarding third-party products or services does not constitute a license to use such products or services or a warranty or endorsement thereof. Use of such information may require a license from a third party under the patents or other intellectual property of the third party, or a license from TI under the patents or other intellectual property of TI.

Reproduction of significant portions of TI information in TI data books or data sheets is permissible only if reproduction is without alteration and is accompanied by all associated warranties, conditions, limitations, and notices. TI is not responsible or liable for such altered documentation. Information of third parties may be subject to additional restrictions.

Resale of TI components or services with statements different from or beyond the parameters stated by TI for that component or service voids all express and any implied warranties for the associated TI component or service and is an unfair and deceptive business practice. TI is not responsible or liable for any such statements.

Buyer acknowledges and agrees that it is solely responsible for compliance with all legal, regulatory and safety-related requirements concerning its products, and any use of TI components in its applications, notwithstanding any applications-related information or support that may be provided by TI. Buyer represents and agrees that it has all the necessary expertise to create and implement safeguards which anticipate dangerous consequences of failures, monitor failures and their consequences, lessen the likelihood of failures that might cause harm and take appropriate remedial actions. Buyer will fully indemnify TI and its representatives against any damages arising out of the use of any TI components in safety-critical applications.

In some cases, TI components may be promoted specifically to facilitate safety-related applications. With such components, TI’s goal is to help enable customers to design and create their own end-product solutions that meet applicable functional safety standards and requirements. Nonetheless, such components are subject to these terms.

No TI components are authorized for use in FDA Class III (or similar life-critical medical equipment) unless authorized officers of the parties have executed a special agreement specifically governing such use.

Only those TI components which TI has specifically designated as military grade or “enhanced plastic” are designed and intended for use in military/aerospace applications or environments. Buyer acknowledges and agrees that any military or aerospace use of TI components which have **not** been so designated is solely at the Buyer’s risk, and that Buyer is solely responsible for compliance with all legal and regulatory requirements in connection with such use.

TI has specifically designated certain components as meeting ISO/TS16949 requirements, mainly for automotive use. In any case of use of non-designated products, TI will not be responsible for any failure to meet ISO/TS16949.

### Products

|                              |  |
|------------------------------|--|
| Audio                        | <a href="http://www.ti.com/audio">www.ti.com/audio</a>                               |
| Amplifiers                   | <a href="http://amplifier.ti.com">amplifier.ti.com</a>                               |
| Data Converters              | <a href="http://dataconverter.ti.com">dataconverter.ti.com</a>                       |
| DLP® Products                | <a href="http://www.dlp.com">www.dlp.com</a>   |
| DSP                          | <a href="http://dsp.ti.com">dsp.ti.com</a>   |
| Clocks and Timers            | <a href="http://www.ti.com/clocks">www.ti.com/clocks</a>                             |
| Interface                    | <a href="http://interface.ti.com">interface.ti.com</a>                               |
| Logic                        | <a href="http://logic.ti.com">logic.ti.com</a>                                       |
| Power Mgmt                   | <a href="http://power.ti.com">power.ti.com</a>                                       |
| Microcontrollers             | <a href="http://microcontroller.ti.com">microcontroller.ti.com</a>                   |
| RFID                         | <a href="http://www.ti-rfid.com">www.ti-rfid.com</a>                                 |
| OMAP Applications Processors | <a href="http://www.ti.com/omap">www.ti.com/omap</a>                                 |
| Wireless Connectivity        | <a href="http://www.ti.com/wirelessconnectivity">www.ti.com/wirelessconnectivity</a> |

### Applications

|                               |  |
|-------------------------------|--|
| Automotive and Transportation | <a href="http://www.ti.com/automotive">www.ti.com/automotive</a>                         |
| Communications and Telecom    | <a href="http://www.ti.com/communications">www.ti.com/communications</a>                 |
| Computers and Peripherals     | <a href="http://www.ti.com/computers">www.ti.com/computers</a>                           |
| Consumer Electronics          | <a href="http://www.ti.com/consumer-apps">www.ti.com/consumer-apps</a>                   |
| Energy and Lighting           | <a href="http://www.ti.com/energy">www.ti.com/energy</a>                                 |
| Industrial                    | <a href="http://www.ti.com/industrial">www.ti.com/industrial</a>                         |
| Medical                       | <a href="http://www.ti.com/medical">www.ti.com/medical</a>                               |
| Security                      | <a href="http://www.ti.com/security">www.ti.com/security</a>                             |
| Space, Avionics and Defense   | <a href="http://www.ti.com/space-avionics-defense">www.ti.com/space-avionics-defense</a> |
| Video and Imaging             | <a href="http://www.ti.com/video">www.ti.com/video</a>                                   |

### TI E2E Community

[e2e.ti.com](http://e2e.ti.com)