

Excellent Integrated System Limited

Stocking Distributor

Click to view price, real time Inventory, Delivery & Lifecycle Information:

[STMicroelectronics](#)
[ESDAVLC8-4BN4](#)

For any questions, you can email us directly:

sales@integrated-circuit.com



ESDAVLC8-4BN4

4-line very low capacitance Transil™ array for ESD protection

Datasheet – production data

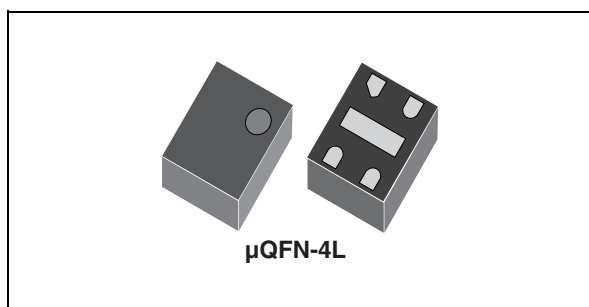
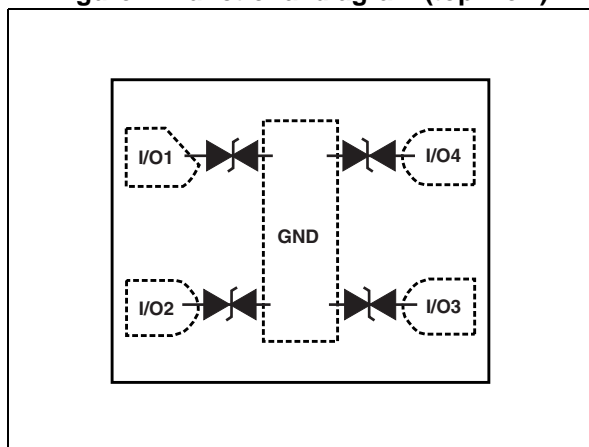

Figure 1. Functional diagram (top view)



Features

- Stand-off voltage: 3 V
- Very low capacitance: 4.5 pF
- Small package: 1.0 x 0.8 mm
- Very thin package: 0.40 mm max
- Low leakage current: 50 nA at 25 °C

Benefits

- High ESD robustness of the equipment
- Suitable for high speed interface

Complies with the following standards:

- IEC 61000-4-2:
 - ±15 kV (air discharge)
 - ±8 kV (contact discharge)
- MIL STD 883G- Method 3015-7: class3B:
 - >25 kV (human body model)

Applications

Where transient overvoltage protection and electrical overstress protection in sensitive equipment is required, such as:

- Communication systems
- Cellular phone handsets and accessories
- Video equipment

Description

The ESDAVLC8-4BN4 is monolithic array designed to protect up to 4 lines against ESD transients. It has been designed specifically for the protection of the high speed interface of integrated circuits in portable equipment and miniaturized electronics devices. The μQFN-4L package minimizes PCB space.

TM: Transil is a trademark of STMicroelectronics.

1 Characteristics

Table 1. Absolute maximum ratings ($T_{amb} = 25\text{ }^{\circ}\text{C}$)

Symbol	Parameter	Value	Unit
V_{PP}	Peak pulse voltage, IEC 61000-4-2, level 4 (contact discharge)	16	kV
P_{PP}	Peak pulse power dissipation (8/20 μs) ⁽¹⁾	GND to I/O	45
	T_j initial = T_{amb}	I/O to GND	32
I_{pp}	Peak pulse current (8/20 μs)	1.6	A
T_j	Maximum junction temperature range	-40 to 125	$^{\circ}\text{C}$
T_{stg}	Storage temperature range	-55 + 150	$^{\circ}\text{C}$

1. For a surge greater than the maximum values, the diode will fail in short-circuit.

Figure 2. Electrical characteristics (definitions)

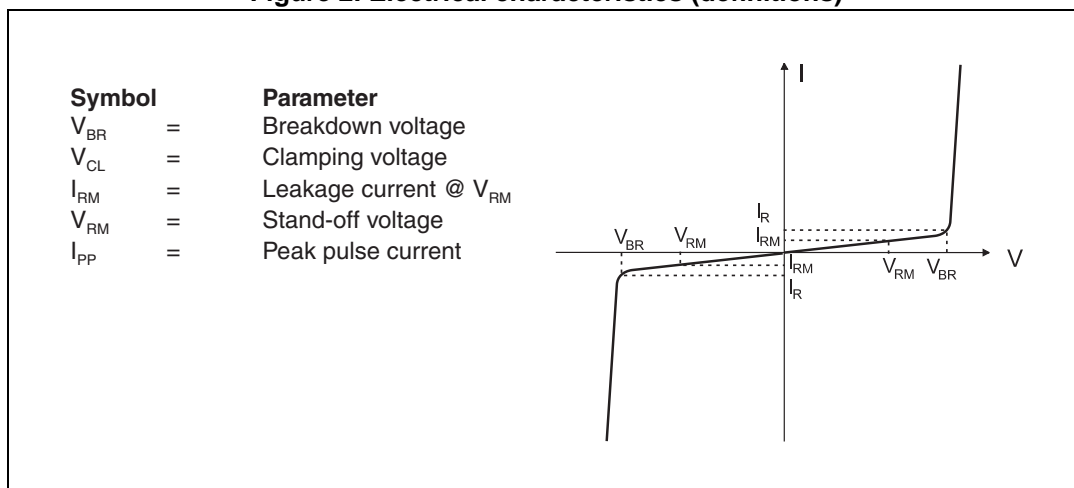

Table 2. Electrical characteristics (values, $T_{amb} = 25\text{ }^{\circ}\text{C}$)

Symbol	Test conditions	Min.	Typ.	Max.	Unit
V_{BR1}	$I_R = 1\text{ mA}$, GND to I/O	8.5	11	14	V
V_{BR2}	$I_R = 1\text{ mA}$, I/O to GND	14.5	17	20	V
I_{RM}	$V_{RM} = 3\text{ V}$			50	nA
V_{CL}	$I_{pp} = 1\text{ A}$, 8/20 μs , GND to I/O			20	V
	$I_{pp} = 1\text{ A}$, 8/20 μs , I/O to GND			28	
C	$V_{I/O} = 0\text{ V}$, $F = 1\text{ MHz}$, $V_{osc} = 30\text{ mV}$		4.5	5.5	pF
R_d	Dynamic resistance, pulse width 100 ns	I/O to GND		0.36	Ω
		GND to I/O		0.28	

Note: For component test in its final application, the minimum clamping voltage has to be 20 V on V_{BR1} (GND to I/O) and 25 V on V_{BR2} (I/O to GND).

ESDAVLC8-4BN4

Characteristics

Figure 3. Peak pulse power versus initial junction temperature (8/20 μ s waveform)

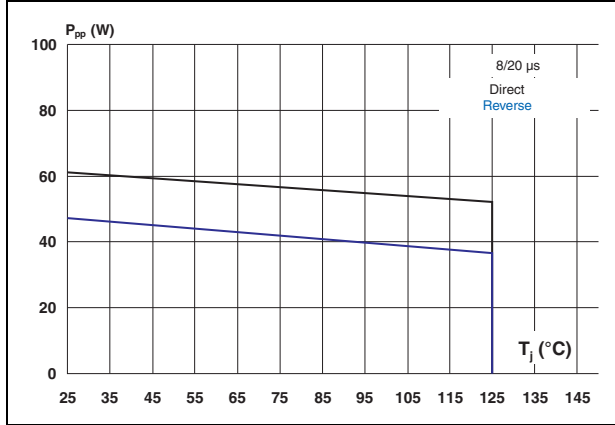

Figure 4. Peak pulse power versus exponential pulse duration

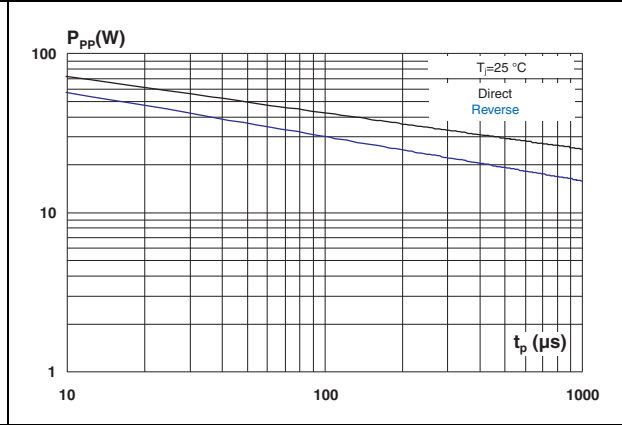

Figure 5. Clamping voltage versus peak pulse current (typical values, 8/20 μ s waveform)

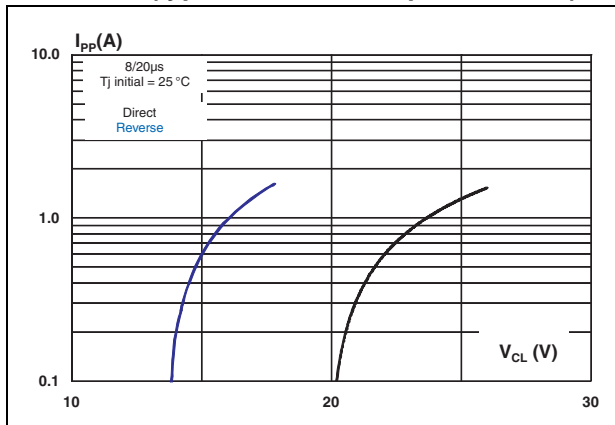

Figure 6. Junction capacitance versus reverse voltage applied (typical values)

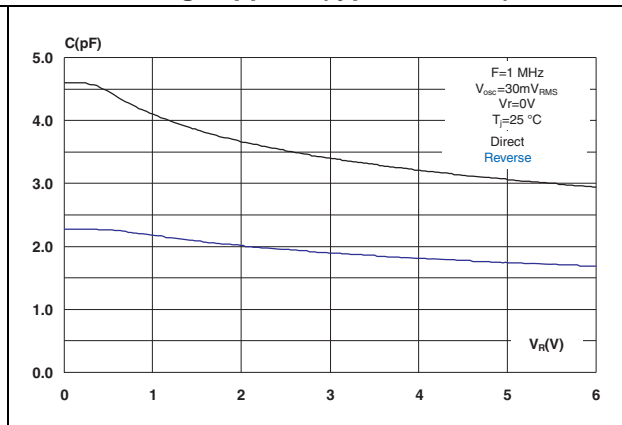

Figure 7. ESD response to IEC 61000-4-2 (+8 kV contact discharge) on each channel

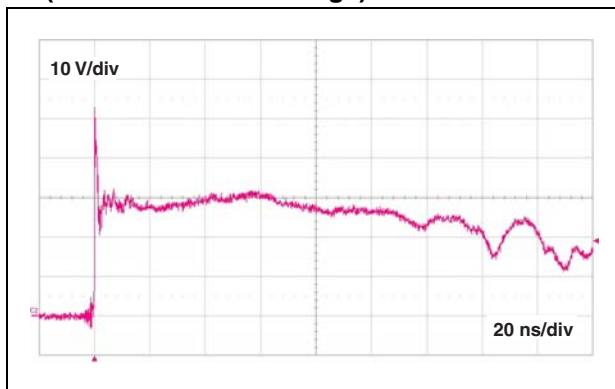
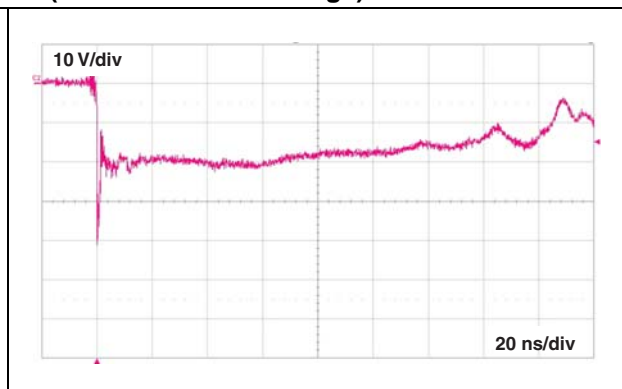

Figure 8. ESD response to IEC 61000-4-2 (-8 kV contact discharge) on each channel



Characteristics

ESDAVLC8-4BN4

Figure 9. S21 attenuation measurement

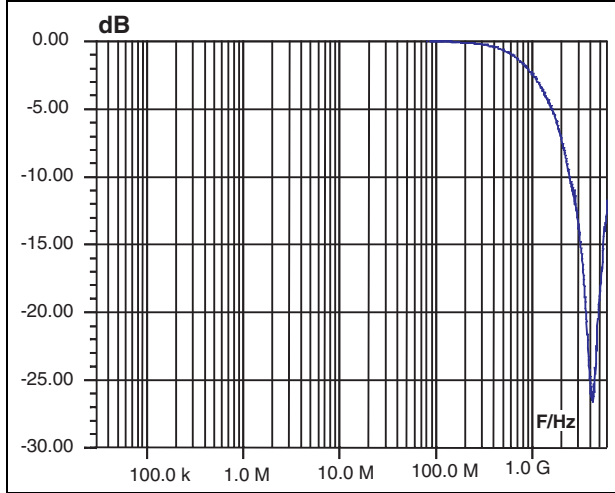

Figure 10. Analog crosstalk measurement

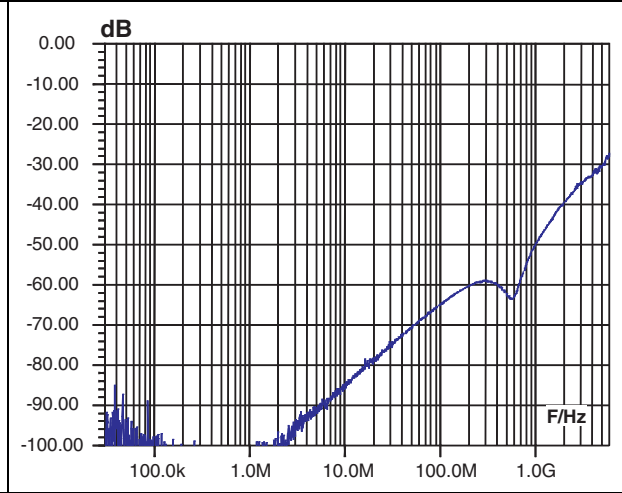

Figure 11. Leakage current versus junction temperature (typical values)

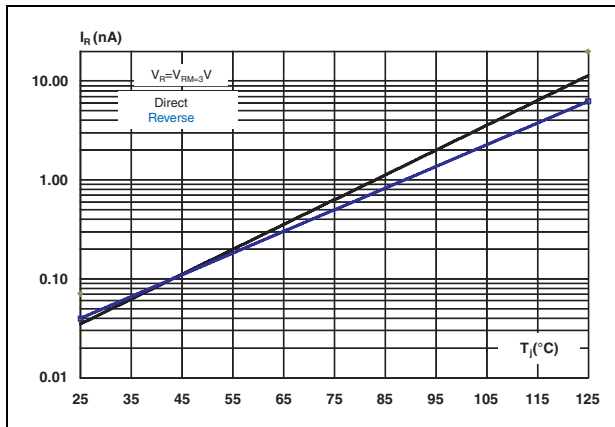
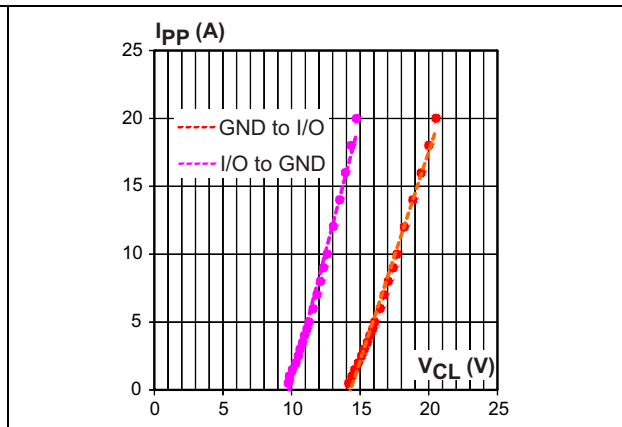

Figure 12. TLP measurement



2 Package information

- Epoxy meets UL94, V0
- Lead-free package

In order to meet environmental requirements, ST offers these devices in different grades of ECOPACK[®] packages, depending on their level of environmental compliance. ECOPACK[®] specifications, grade definitions and product status are available at: www.st.com. ECOPACK[®] is an ST trademark.

Figure 13. μ QFN-4L dimension definitions

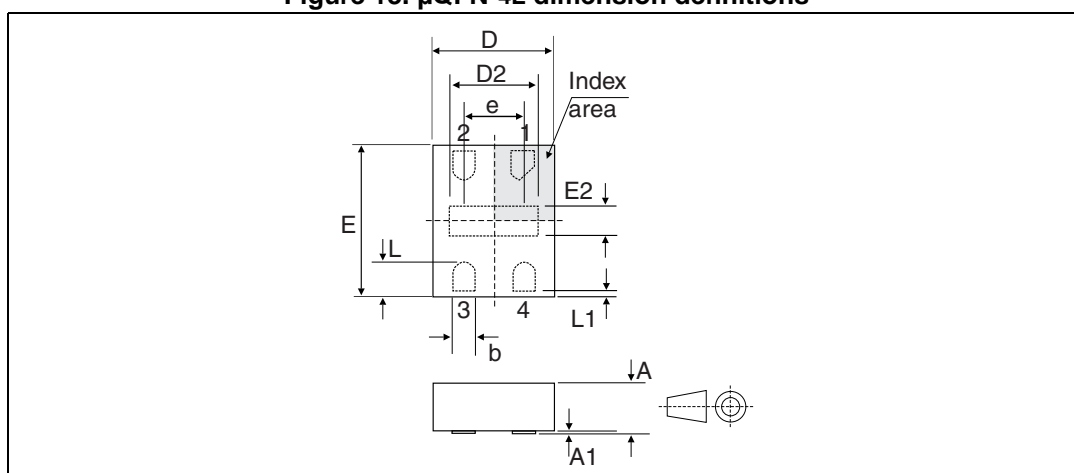

Table 3. μ QFN-4L dimension values

Ref.	Dimensions					
	Millimeters			Inches		
	Min.	Typ.	Max.	Min.	Typ.	Max.
A	0.31	0.38	0.40	0.012	0.015	0.016
A1	0.00	0.02	0.05	0.00	0.0008	0.002
b	0.10	0.15	0.20	0.004	0.006	0.008
D	0.70	0.80	0.90	0.028	0.031	0.035
D2	0.50	0.58	0.65	0.020	0.023	0.026
e	0.35	0.40	0.45	0.014	0.016	0.018
E	0.90	1.00	1.10	0.035	0.039	0.043
E2	0.15	0.20	0.25	0.006	0.008	0.010
L	0.18	0.23	0.28	0.007	0.009	0.011
L1	0.00	--	0.05	0.00	--	0.002

Package information

ESDAVLC8-4BN4

Figure 14. Footprint dimensions (in mm)

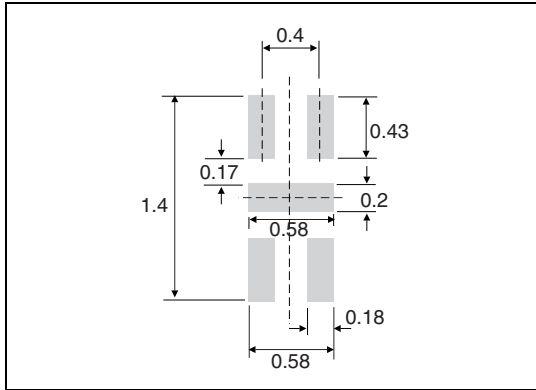
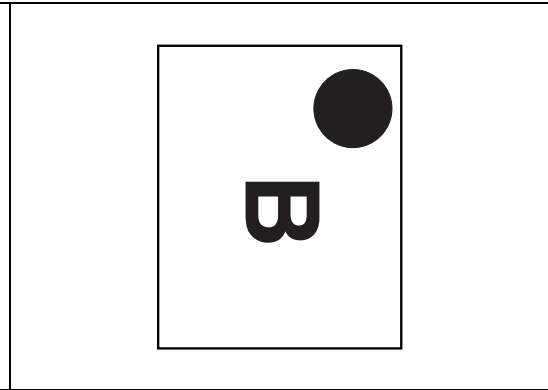
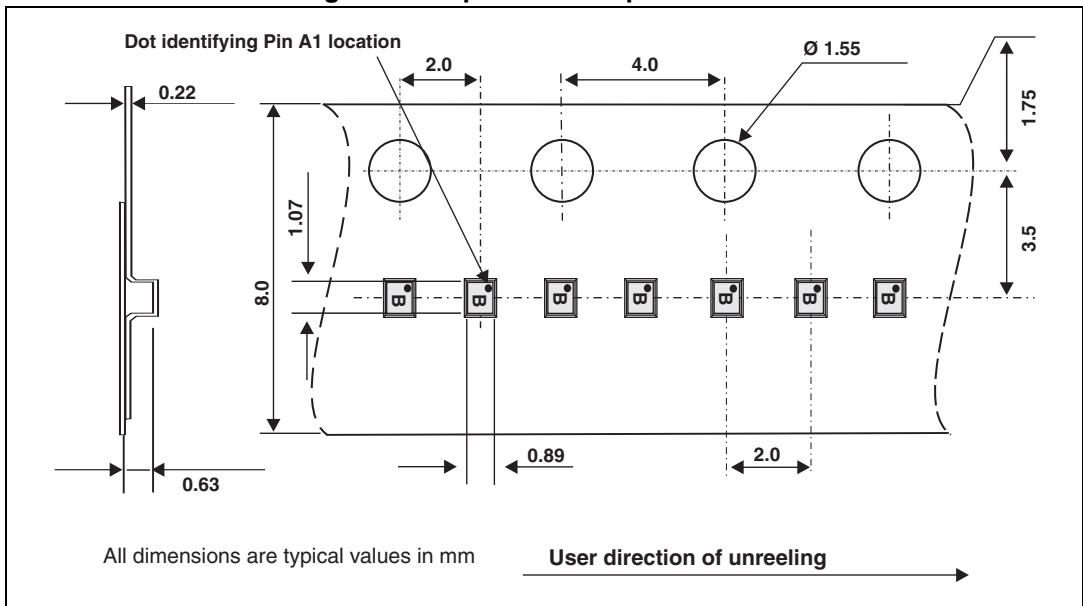

Figure 15. Marking



Note: Product marking may be rotated by multiples of 90° for assembly plant differentiation. In no case should this product marking be used to orient the component for its placement on a PCB. Only pin 1 mark is to be used for this purpose.

Figure 16. Tape and reel specifications



3 Recommendation on PCB assembly

3.1 Stencil opening design

Reference design

- Stencil opening thickness: 100 μm
- Stencil opening for leads: Opening to footprint ratio is 100%.

Figure 17. Recommended stencil window position

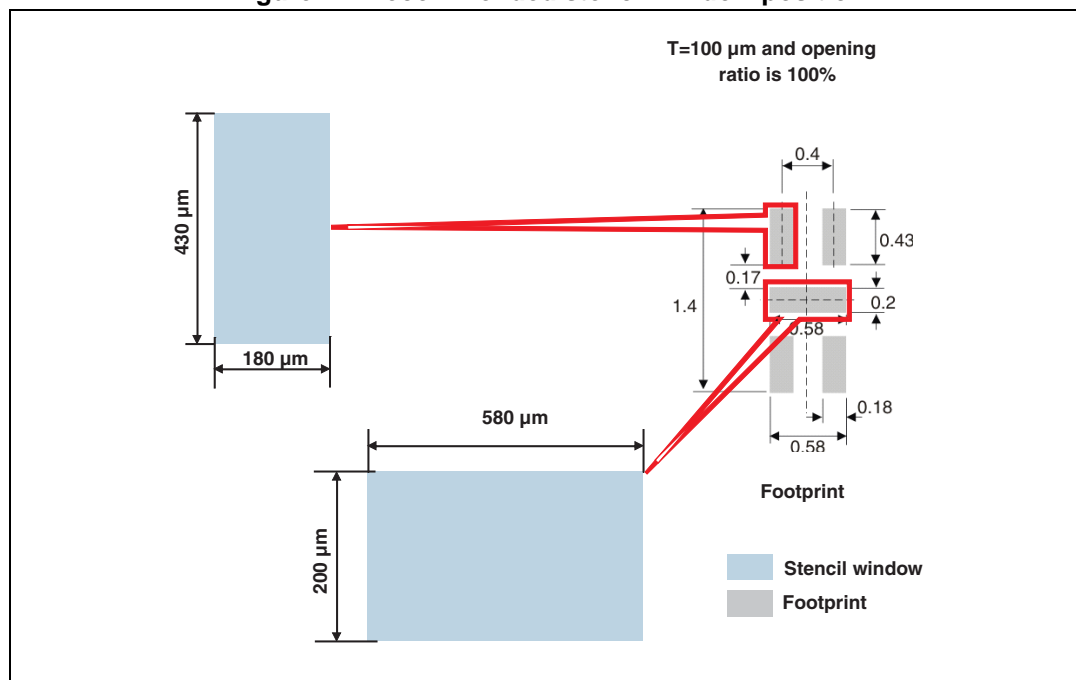

3.2 Solder paste

1. Halide-free flux qualification ROL0 according to ANSI/J-STD-004.
2. “No clean” solder paste is recommended.
3. Offers a high tack force to resist component movement during high speed.
4. Solder paste with fine particles: powder particle size is 20-45 μm .

Recommendation on PCB assembly

ESDAVLC8-4BN4

3.3 Placement

1. Manual positioning is not recommended.
2. It is recommended to use the lead recognition capabilities of the placement system, not the outline centering.
3. Standard tolerance of ± 0.05 mm is recommended.
4. 3.5 N placement force is recommended. Too much placement force can lead to squeezed out solder paste and cause solder joints to short. Too low placement force can lead to insufficient contact between package and solder paste that could cause open solder joints or badly centered packages.
5. To improve the package placement accuracy, a bottom side optical control should be performed with a high resolution tool.
6. For assembly, a perfect supporting of the PCB (all the more on flexible PCB) is recommended during solder paste printing, pick and place and reflow soldering by using optimized tools.

3.4 PCB design preference

1. To control the solder paste amount, the closed via is recommended instead of open vias.
2. The position of tracks and open vias in the solder area should be well balanced. The symmetrical layout is recommended, in case any tilt phenomena caused by asymmetrical solder paste amount due to the solder flow away.

3.5 Reflow profile

Figure 18. ST ECOPACK® recommended soldering reflow profile for PCB mounting

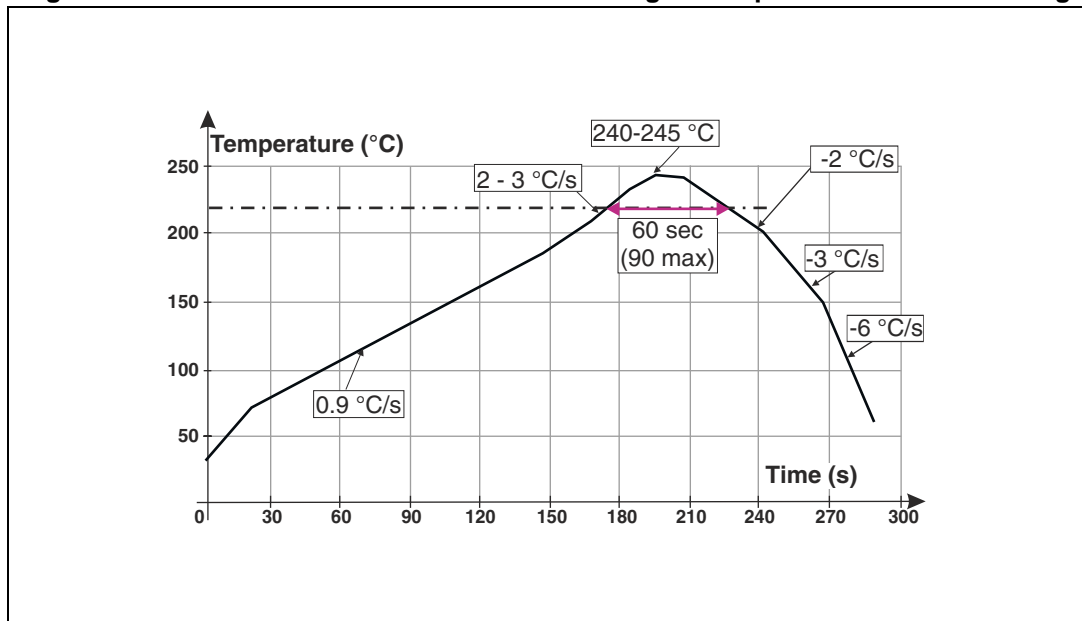

Note: Minimize air convection currents in the reflow oven to avoid component movement.

4 Ordering information

Figure 19. Ordering information scheme

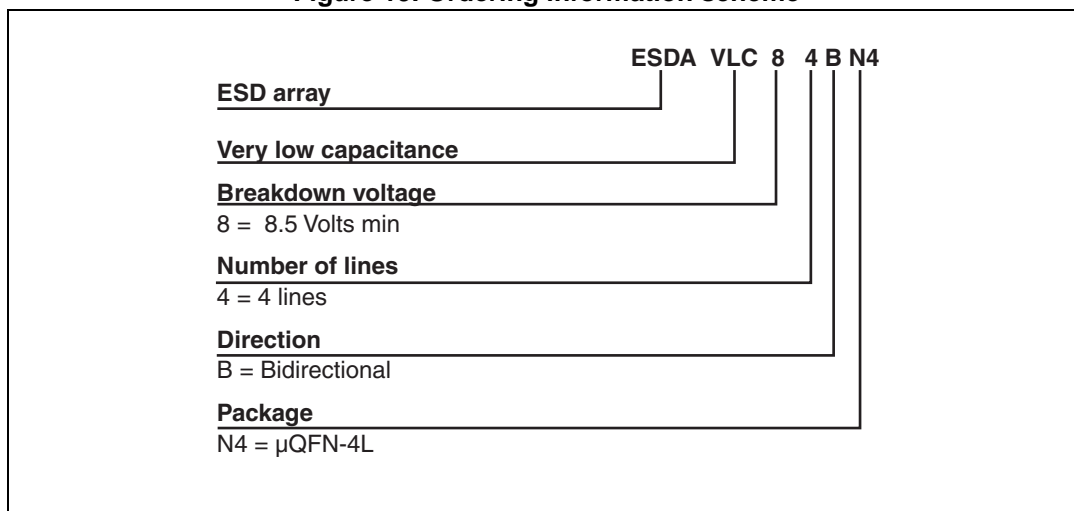

Table 4. Ordering information

Order code	Marking	Package	Weight	Base qty	Delivery mode
ESDAVLC8-4BN4	B ⁽¹⁾	μQFN-4L	1.17 mg	10000	Tape and reel

1. The marking can be rotated by multiples of 90° to differentiate assembly location

5 Revision history

Table 5. Document revision history

Date	Revision	Changes
06-Sep-2011	1	Initial release.
25-Sep-2012	2	Updated ECOPACK statement.
25-Mar-2014	3	For Table 2 added maximum values for V_{BR1} and V_{BR2} , and the note following the table. Updated values for dynamic resistance in Table 2 and added Figure 12 .

ESDAVLC8-4BN4

Please Read Carefully:

Information in this document is provided solely in connection with ST products. STMicroelectronics NV and its subsidiaries ("ST") reserve the right to make changes, corrections, modifications or improvements, to this document, and the products and services described herein at any time, without notice.

All ST products are sold pursuant to ST's terms and conditions of sale.

Purchasers are solely responsible for the choice, selection and use of the ST products and services described herein, and ST assumes no liability whatsoever relating to the choice, selection or use of the ST products and services described herein.

No license, express or implied, by estoppel or otherwise, to any intellectual property rights is granted under this document. If any part of this document refers to any third party products or services it shall not be deemed a license grant by ST for the use of such third party products or services, or any intellectual property contained therein or considered as a warranty covering the use in any manner whatsoever of such third party products or services or any intellectual property contained therein.

UNLESS OTHERWISE SET FORTH IN ST'S TERMS AND CONDITIONS OF SALE ST DISCLAIMS ANY EXPRESS OR IMPLIED WARRANTY WITH RESPECT TO THE USE AND/OR SALE OF ST PRODUCTS INCLUDING WITHOUT LIMITATION IMPLIED WARRANTIES OF MERCHANTABILITY, FITNESS FOR A PARTICULAR PURPOSE (AND THEIR EQUIVALENTS UNDER THE LAWS OF ANY JURISDICTION), OR INFRINGEMENT OF ANY PATENT, COPYRIGHT OR OTHER INTELLECTUAL PROPERTY RIGHT.

ST PRODUCTS ARE NOT DESIGNED OR AUTHORIZED FOR USE IN: (A) SAFETY CRITICAL APPLICATIONS SUCH AS LIFE SUPPORTING, ACTIVE IMPLANTED DEVICES OR SYSTEMS WITH PRODUCT FUNCTIONAL SAFETY REQUIREMENTS; (B) AERONAUTIC APPLICATIONS; (C) AUTOMOTIVE APPLICATIONS OR ENVIRONMENTS, AND/OR (D) AEROSPACE APPLICATIONS OR ENVIRONMENTS. WHERE ST PRODUCTS ARE NOT DESIGNED FOR SUCH USE, THE PURCHASER SHALL USE PRODUCTS AT PURCHASER'S SOLE RISK, EVEN IF ST HAS BEEN INFORMED IN WRITING OF SUCH USAGE, UNLESS A PRODUCT IS EXPRESSLY DESIGNATED BY ST AS BEING INTENDED FOR "AUTOMOTIVE, AUTOMOTIVE SAFETY OR MEDICAL" INDUSTRY DOMAINS ACCORDING TO ST PRODUCT DESIGN SPECIFICATIONS. PRODUCTS FORMALLY ESCC, QML OR JAN QUALIFIED ARE DEEMED SUITABLE FOR USE IN AEROSPACE BY THE CORRESPONDING GOVERNMENTAL AGENCY.

Resale of ST products with provisions different from the statements and/or technical features set forth in this document shall immediately void any warranty granted by ST for the ST product or service described herein and shall not create or extend in any manner whatsoever, any liability of ST.

ST and the ST logo are trademarks or registered trademarks of ST in various countries.

Information in this document supersedes and replaces all information previously supplied.

The ST logo is a registered trademark of STMicroelectronics. All other names are the property of their respective owners.

© 2014 STMicroelectronics - All rights reserved

STMicroelectronics group of companies

Australia - Belgium - Brazil - Canada - China - Czech Republic - Finland - France - Germany - Hong Kong - India - Israel - Italy - Japan - Malaysia - Malta - Morocco - Philippines - Singapore - Spain - Sweden - Switzerland - United Kingdom - United States of America

www.st.com