

Excellent Integrated System Limited

Stocking Distributor

Click to view price, real time Inventory, Delivery & Lifecycle Information:

[TT Electronics/Optek Technology](#)
[OPB917B](#)

For any questions, you can email us directly:

sales@integrated-circuit.com



Product Bulletin OPB917
 February 2001

Photologic[®] Slotted Optical Switches Type OPB917 Series

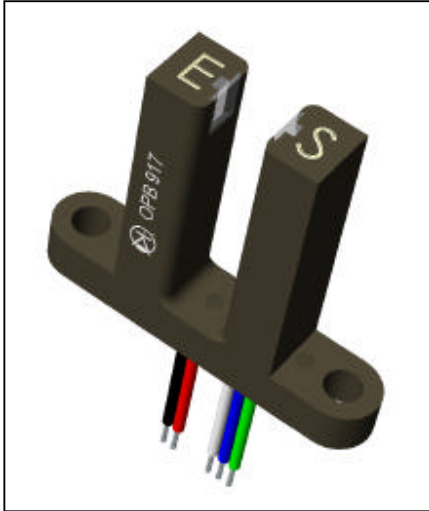

Features

- Choice of output configuration
- 24" min 26 AWG wires
- Low power consumption
- 0.86" (21.8 mm) deep slot

Description

The OPB917 consists of an infrared emitting diode and a Photologic[®] photo integrated circuit mounted in an opaque housing with clear windows for dust protection. The extended deep slot allows for a longer reach of the optical path from the mounting plane, .900" (22.86 mm).

Internal apertures are .010" x 0.06" for the Photologic's "S side" and .050" x 0.06" for the LED, "E side". Two logic states and two electrical output types are available. Custom electrical, wire or cabling are available. Contact your local representative or Optek for more information.

Visit our website at www.optekinc.com
 or email us at sensors@optekinc.com

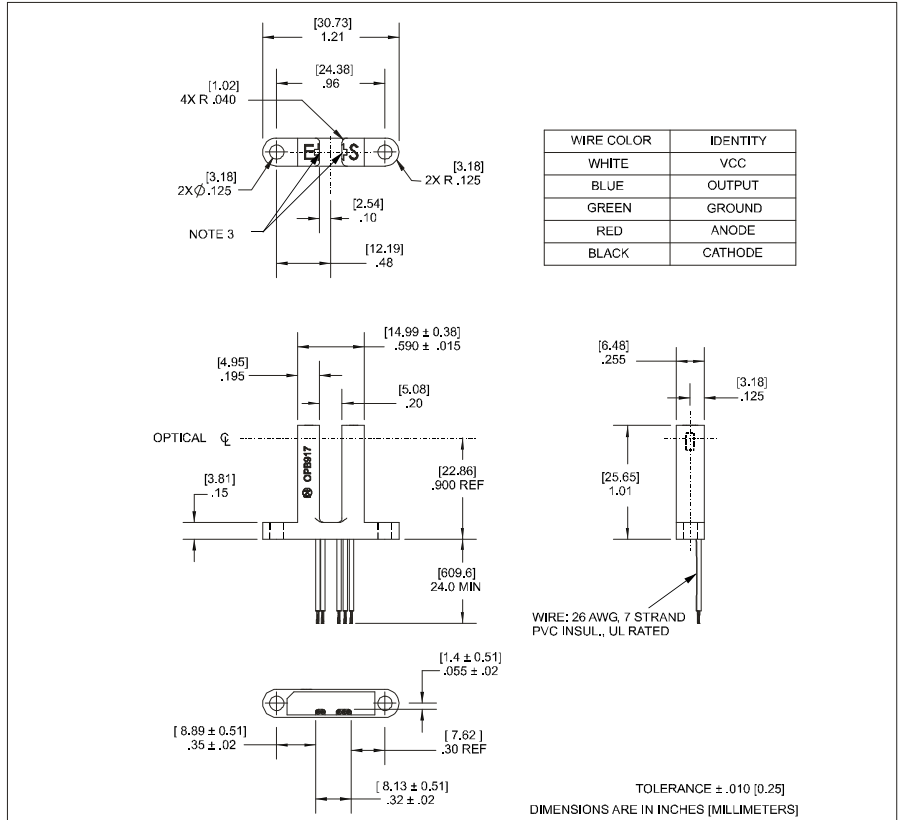

Absolute Maximum Ratings (T_A = 25° C unless otherwise noted)

Supply Voltage V _{CC} (Not to exceed 3 sec.)	18 V
Storage and Operating Temperature Range	-40° C to +80° C
Input Diode Power Dissipation	100 mW ⁽¹⁾
Output Photologic [®] Power Dissipation	90 mW ⁽²⁾
Voltage at Output Lead (Open Collector Output)	35 V
Diode Forward D.C. Current	50 mA
Diode Reverse D.C. Voltage	2 V

NOTES:

- (1) Derate linearly 1.67 mW/° C above 25° C.
- (2) Derate linearly 2.67 mW/° C above 70° C.
- (3) Clear dust protection.
- (4) Normal application would be with light source blocked, simulated by I_F = 0 mA.
- (5) All parameters tested using pulse technique.

PRECAUTIONS: Exposure of the plastic body to chlorinated hydrocarbons and ketones such as thread lock and instant adhesive products will degrade the plastic body. Cleaning agents methanol and isopropanol are recommended. Spray or wipe do not submerge.

Type OPB917 Series

PART NUMBER GUIDE

O P B 9 1 7 X X X

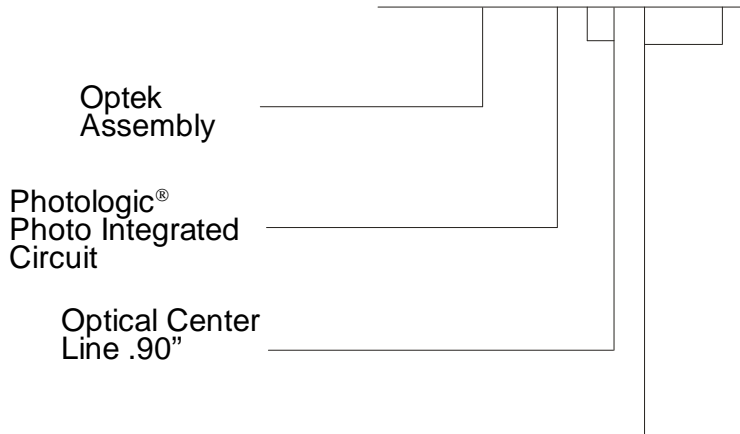

Electrical Specification Variations

B - Buffered with 10K Ω pull-up

BOC - Buffered Open-Collector Output

I - Inverted with 10K Ω pull-up

IOC - Inverted Open-Collector Output

Schematics

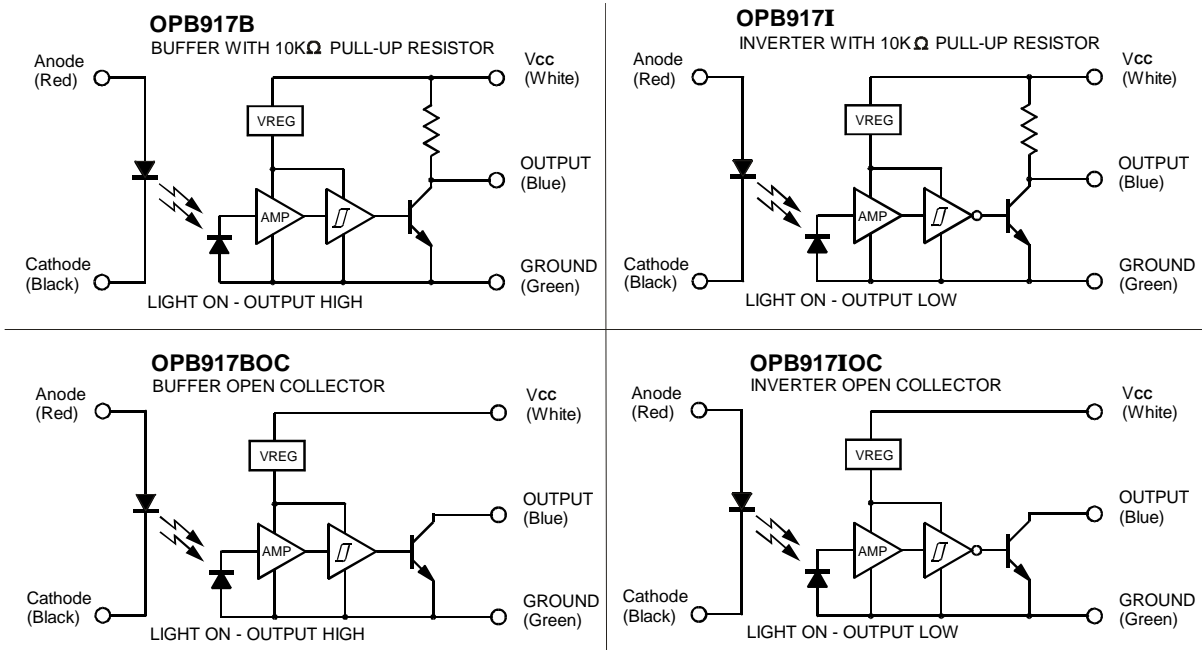

SLOTTED
OPTICAL
SWITCHES

Type OPB917 Series

Electrical Characteristics ($T_A = 25^\circ\text{C}$ unless otherwise noted)

SYMBOL	PARAMETER	MIN	TYP	MAX	UNITS	TEST CONDITIONS
Input Diode						
V_F	Forward Voltage		1.30	1.80	V	$I_F = 20\text{ mA}$
I_R	Reverse Current			100	μA	$V_R = 2\text{ V}$
Phototransistor						
V_{CC}	Operating D.C. Supply Voltage	4.5		16.0	V	
I_{CCL}	Low Level Supply Current: OPB917B and OPB917BOC			7.0	mA	$V_{CC} = 16\text{ V}$, $I_F = 0\text{ mA}^{(4)}$ No Output Load
	OPB917I and OPB917IOC			7.0	mA	$V_{CC} = 16\text{ V}$, $I_F = 10\text{ mA}$ No Output Load
I_{CCH}	High Level Supply Current: OPB917B and OPB917BOC			6.0	mA	$V_{CC} = 16\text{ V}$, $I_F = 10\text{ mA}$ No Output Load
	OPB917I and OPB917IOC			6.0	mA	$V_{CC} = 16\text{ V}$, $I_F = 0\text{ mA}^{(4)}$ No Output Load
V_{OL}	Low Level Output Voltage: OPB917B			0.4	V	$V_{CC} = 4.5\text{ to }16\text{ V}$, $I_F = 0\text{ mA}^{(4)}$ No Output Load
	OPB917BOC			0.4	V	$V_{CC} = 4.5\text{ to }16\text{ V}$, $I_F = 0\text{ mA}^{(4)}$, $I_{OL} = 16\text{ mA}$ No Output Load
	OPB917I			0.4	V	$V_{CC} = 4.5\text{ to }16\text{ V}$, $I_F = 10\text{ mA}$ No Output Load
	OPB917IOC			0.4	V	$V_{CC} = 4.5\text{ to }16\text{ V}$, $I_F = 10\text{ mA}$, $I_{OL} = 16\text{ mA}$ No Output Load
V_{OH}	Low Level Output Voltage: OPB917B	2.4	$V_{CC} - 1.5$		V	$V_{CC} = 4.5\text{ to }16\text{ V}$, $I_F = 10\text{ mA}$ No Output Load
	OPB917I	2.4	$V_{CC} - 1.5$		V	$V_{CC} = 4.5\text{ to }16\text{ V}$, $I_F = 0\text{ mA}^{(4)}$, No Output Load
I_{OH}	High Level Output Current: OPB917BOC		1.0	14	μA	$V_{CC} = 4.5\text{ V}$, $V_{OH} = 30\text{ V}$, $I_F = 10\text{ mA}$
	OPB917IOC		1.0	14	μA	$V_{CC} = 4.5\text{ V}$, $V_{OH} = 30\text{ V}$, $I_F = 0\text{ mA}$
$I_F(+)$	LED Positive-Going Threshold Current: OPB917B and OPB917I		5	10	mA	$V_{CC} = 5\text{ V}$ No Output Load
	OPB917BOC and OPB917IOC		5	10	mA	$V_{CC} = 5\text{ V}$, $I_{OL} = 16\text{ mA}$ No Output Load
$I_F(+)/I_F(-)$	Hysteresis		1.5			
t_r, t_f	Rise Time, Fall Time		50		ns	$V_{CC} = 5\text{ V}$, $I_F = 0\text{ or }10\text{ mA}$
t_{PLH}, t_{PHL}	Propagation Delay Low-High & High-Low		3.0		μs	$R_L = 300\ \Omega\text{ to }5\text{ V}$, $C_L = 50\text{ pF}$

SLOTTED OPTICAL SWITCH

Optek reserves the right to make changes at any time in order to improve design and to supply the best product possible.

Optek Technology, Inc. 1215 W. Crosby Road Carrollton, Texas 75006 (972)323-2200 Fax (972)323-2396