



Distributor of Texas Instruments: Excellent Integrated System Limited

Datasheet of SN74LS251DR - IC 8-TO-1 LINE SEL/MUX 16-SOIC

Contact us: sales@integrated-circuit.com Website: www.integrated-circuit.com

Excellent Integrated System Limited

Stocking Distributor

Click to view price, real time Inventory, Delivery & Lifecycle Information:

[Texas Instruments](#)
[SN74LS251DR](#)

For any questions, you can email us directly:

sales@integrated-circuit.com

**SN54251, SN54LS251 SN54S251,
SN74251, SN74LS251, (TIM9905), SN74S251
DATA SELECTORS/MULTIPLEXERS WITH 3-STATE OUTPUTS**

SDLS085 - DECEMBER 1972 - REVISED MARCH 1988

- Three-State Versions of '151, 'LS151, 'S151
- Three-State Outputs Interface Directly with System Bus
- Perform Parallel-to-Serial Conversion
- Permit Multiplexing from N-lines to One Line
- Complementary Outputs Provide True and Inverted Data
- Fully Compatible with Most TTL Circuits

SN54251, SN54LS251, SN54S251 . . . J OR W PACKAGE

SN74251 . . . N PACKAGE

SN74LS251, SN74S251 . . . D OR N PACKAGE

(TOP VIEW)

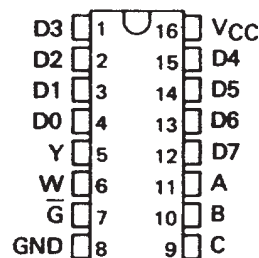

TYPE	MAX NO. OF COMMON OUTPUTS	TYPICAL AVG PROP DELAY TIME (D TO Y)	TYPICAL POWER DISSIPATION
SN54251	49	17 ns	250 mW
SN74251	129	17 ns	250 mW
SN54LS251	49	17 ns	35 mW
SN74LS251	129	17 ns	35 mW
SN54S251	39	8 ns	275 mW
SN74S251	129	8 ns	275 mW

SN54LS251, SN54S251 . . . FK PACKAGE

(TOP VIEW)

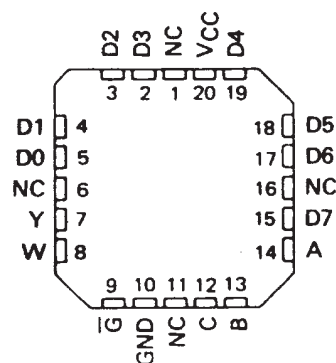

NC - No internal connection

description

These monolithic data selectors/multiplexers contain full on-chip binary decoding to select one-of-eight data sources and feature a strobe-controlled three-state output. The strobe must be at a low logic level to enable these devices. The three-state outputs permit a number of outputs to be connected to a common bus. When the strobe input is high, both outputs are in a high-impedance state in which both the upper and lower transistors of each totem-pole output are off, and the output neither drives nor loads the bus significantly. When the strobe is low, the outputs are activated and operate as standard TTL totem-pole outputs.

To minimize the possibility that two outputs will attempt to take a common bus to opposite logic levels, the output control circuitry is designed so that the average output disable time is shorter than the average output enable time. The SN54251 and SN74251 have output clamp diodes to attenuate reflections on the bus line.

FUNCTION TABLE

INPUTS				OUTPUTS	
SELECT			ENABLE	Y	W
C	B	A	G		
X	X	X	H	Z	Z
L	L	L	L	D0	$\overline{D0}$
L	L	H	L	D1	$\overline{D1}$
L	H	L	L	D2	$\overline{D2}$
L	H	H	L	D3	$\overline{D3}$
H	L	L	L	D4	$\overline{D4}$
H	L	H	L	D5	$\overline{D5}$
H	H	L	L	D6	$\overline{D6}$
H	H	H	L	D7	$\overline{D7}$

H = high logic level, L = low logic level
X = irrelevant, Z = high impedance (off)
D0, D1 . . . D7 = the level of the respective D input

**SN54251, SN54LS251 SN54S251,
SN74251, SN74LS251, (TIM9905), SN74S251
DATA SELECTORS/MULTIPLEXERS WITH 3-STATE OUTPUTS**
SDLS085 - DECEMBER 1972 - REVISED MARCH 1988

logic diagram (positive logic)

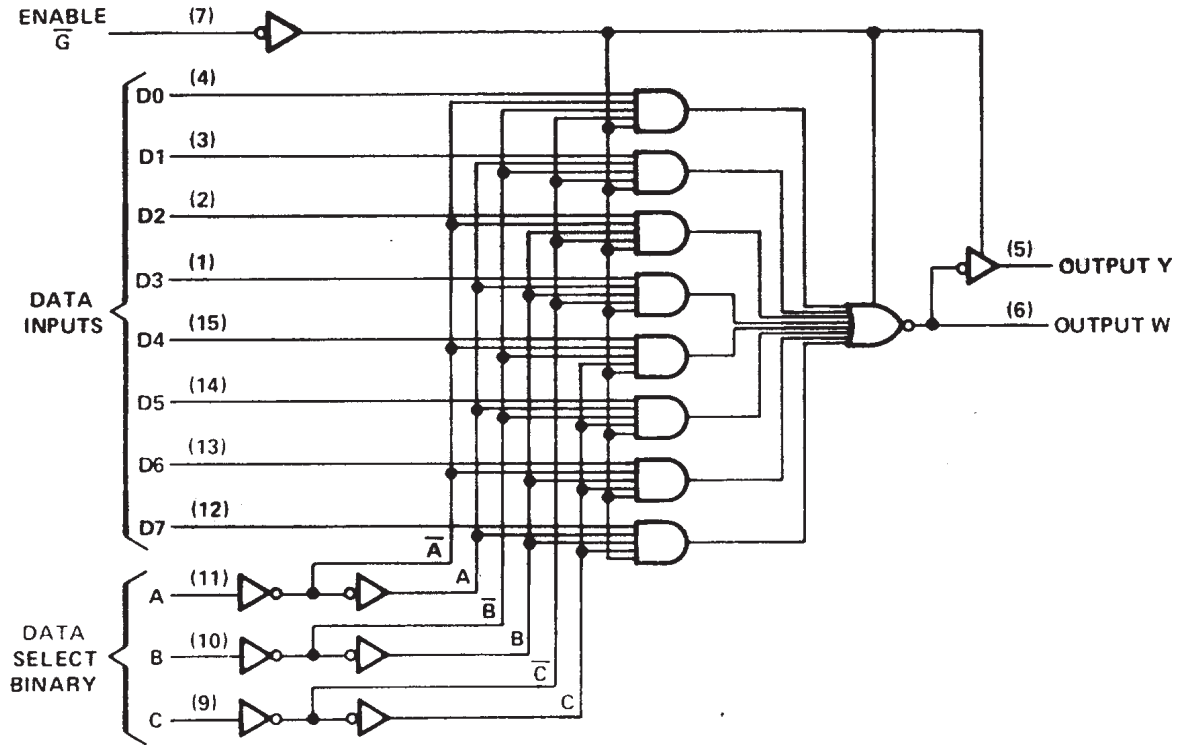

logic symbol†

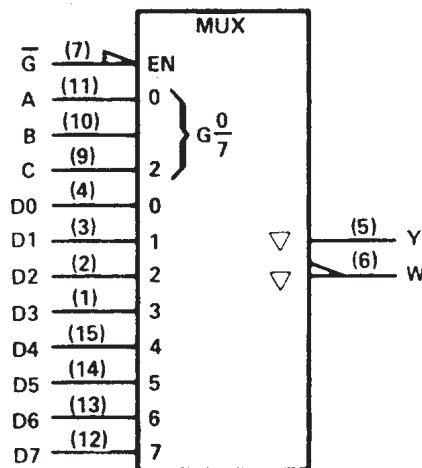

† This symbol is in accordance with ANSI/IEEE Std. 91-1984 and IEC Publication 617-12. Pin numbers shown are for D, J, N, and W packages.

SN54251 SN74251, DATA SELECTORS/MULTIPLEXERS WITH 3-STATE OUTPUTS

SDLS085 – DECEMBER 1972 – REVISED MARCH 1988

absolute maximum ratings over operating free-air temperature range (unless otherwise noted)

Supply voltage, V_{CC} (see Note 1)	7 V
Input voltage	5.5 V
Off-state output voltage	5.5 V
Operating free-air temperature range: SN54251	-55°C to 125°C
SN74251	0°C to 70°C
Storage temperature range	-65°C to 150°C

NOTE 1: Voltage values are with respect to network ground terminal.

recommended operating conditions

	SN54251			SN74251			UNIT
	MIN	NOM	MAX	MIN	NOM	MAX	
Supply voltage, V_{CC}	4.5	5	5.5	4.75	5	5.25	V
High-level output current, I_{OH}			-2			-5.2	mA
Low-level output current, I_{OL}			16			16	mA
Operating free-air temperature, T_A	-55		125	0		70	°C

electrical characteristics over recommended operating free-air temperature range (unless otherwise noted)

PARAMETER	TEST CONDITIONS†	MIN	TYP‡	MAX	UNIT
V_{IH} High-level input voltage		2			V
V_{IL} Low-level input voltage				0.8	V
V_{IK} Input clamp voltage	$V_{CC} = \text{MIN}, I_I = -12 \text{ mA}$			-1.5	V
V_{OH} High-level output voltage	$V_{CC} = \text{MIN}, V_{IH} = 2 \text{ V}, V_{IL} = 0.8 \text{ V}, I_{OH} = \text{MAX}$	2.4	3.2		V
V_{OL} Low-level output voltage	$V_{CC} = \text{MIN}, V_{IH} = 2 \text{ V}, V_{IL} = 0.8 \text{ V}, I_{OL} = 16 \text{ mA}$		0.2	0.4	V
I_{OZ} Off-state (high-impedance-state) output current	$V_{CC} = \text{MAX}, V_{IH} = 2 \text{ V}$			40	μA
V_O Output clamp voltage	$V_{CC} = \text{MAX}, I_O = -12 \text{ mA}$			-1.5	V
	$V_{CC} = \text{MAX}, V_{IH} = 4.5 \text{ V}, I_O = 12 \text{ mA}$			$V_{CC} + 1.5$	
I_I Input current at maximum input voltage	$V_{CC} = \text{MAX}, V_I = 5.5 \text{ V}$			1	mA
I_{IH} High-level input current	$V_{CC} = \text{MAX}, V_I = 2.4 \text{ V}$			40	μA
I_{IL} Low-level input current	$V_{CC} = \text{MAX}, V_I = 0.4 \text{ V}$			-1.6	mA
I_{OS} Short-circuit output current§	$V_{CC} = \text{MAX}$	-18		-55	mA
I_{CC} Supply current	$V_{CC} = \text{MAX},$ All inputs at 4.5 V, All outputs open		38	62	mA

† For conditions shown as MIN or MAX, use the appropriate value specified under recommended operating conditions for the applicable type.

‡ All typical values are at $V_{CC} = 5 \text{ V}, T_A = 25^\circ\text{C}$.

§ Not more than one output should be shorted at a time.

**SN54251 SN74251,
 DATA SELECTORS/MULTIPLEXERS WITH 3-STATE OUTPUTS**

SDLS085 – DECEMBER 1972 – REVISED MARCH 1988

switching characteristics, $V_{CC} = 5\text{ V}$, $T_A = 25^\circ\text{C}$

PARAMETER†	FROM (INPUT)	TO (OUTPUT)	TEST CONDITIONS	MIN	TYP	MAX	UNIT
t _{PLH}	A, B, or C (4 levels)	Y	C _L = 50 pF, R _L = 400 Ω, See Note 2	29	45	ns	
t _{PHL}				28	45		
t _{PLH}	A, B, or C (3 levels)	W		20	33	ns	
t _{PHL}				21	33		
t _{PLH}	Any D	Y		17	28	ns	
t _{PHL}				18	28		
t _{PLH}	Any D	W		10	15	ns	
t _{PHL}				9	15		
t _{PZH}	\bar{G}	Y		17	27	ns	
t _{PZL}				26	40		
t _{PZH}	\bar{G}	W		17	27	ns	
t _{PZL}				24	40		
t _{PHZ}	\bar{G}	Y		C _L = 5 pF, R _L = 400 Ω, See Note 2	5	8	ns
t _{PLZ}					15	23	
t _{PHZ}	\bar{G}	W			5	8	ns
t _{PLZ}					15	23	

- †t_{PLH} = Propagation delay time, low-to-high-level output
- t_{PHL} = Propagation delay time, high-to-low-level output
- t_{PZH} = Output enable time to high level
- t_{PZL} = Output enable time to low level
- t_{PHZ} = Output disable time from high level
- t_{PLZ} = Output disable time from low level

NOTE 2: Load circuits and voltage waveforms are shown in Section 1.

schematics of inputs and outputs

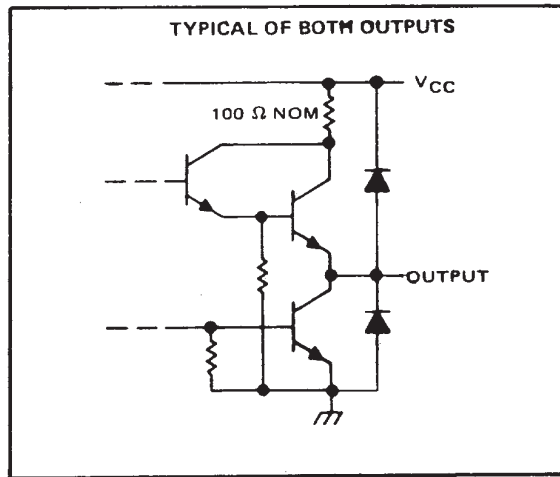
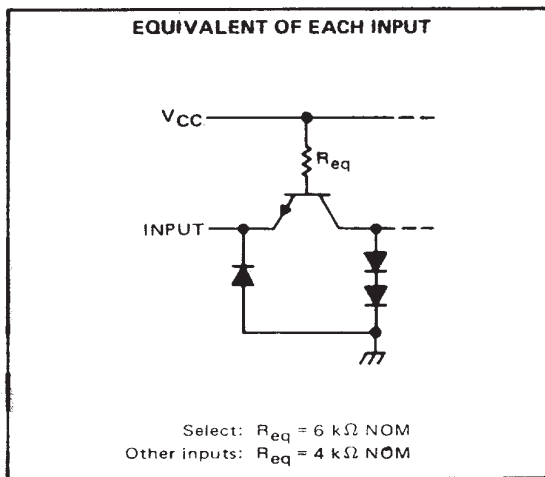

SN54LS251 SN74LS251, DATA SELECTORS/MULTIPLEXERS WITH 3-STATE OUTPUTS

SDLS085 – DECEMBER 1972 – REVISED MARCH 1988

absolute maximum ratings over operating free-air temperature range (unless otherwise noted)

Supply voltage, V_{CC} (see Note 1)	7 V
Input voltage	7 V
Off-state output voltage	5.5 V
Operating free-air temperature range: SN54LS251	55°C to 125°C
SN74LS251	0°C to 70°C
Storage temperature range	-65°C to 150°C

NOTE 1: Voltage values are with respect to network ground terminal.

recommended operating conditions

	SN54LS251			SN74LS251			UNIT
	MIN	NOM	MAX	MIN	NOM	MAX	
V_{CC} Supply voltage	4.5	5	5.5	4.75	5	5.25	V
V_{IH} High-level input voltage	2			2			V
V_{IL} Low-level input voltage			0.7			0.8	V
I_{OH} High-level output current			-1			-2.6	mA
I_{OL} Low-level output current			4			8	mA
T_A Operating free-air temperature	-55		125	0		70	°C

electrical characteristics over recommended operating free-air temperature range (unless otherwise noted)

PARAMETER	TEST CONDITIONS†	SN54LS251		SN74LS251		UNIT		
		MIN	TYP ‡	MAX	MIN		TYP ‡	MAX
V_{IK}	$V_{CC} = \text{MIN}, I_I = -18 \text{ mA}$			-1.5		-1.5	V	
V_{OH}	$V_{CC} = \text{MIN}, V_{IH} = 2 \text{ V}, V_{IL} = \text{MAX}, I_{OH} = \text{MAX}$	2.4	3.4		2.4	3.1	V	
V_{OL}	$V_{CC} = \text{MIN}, V_{IH} = 2 \text{ V}, V_{IL} = \text{MAX}$	$I_{OL} = 4 \text{ mA}$		0.25	0.4	0.25	0.4	
		$I_{OL} = 8 \text{ mA}$				0.35	0.5	
I_{OZ}	$V_{CC} = \text{MAX}, V_{IH} = 2 \text{ V}$	$V_O = 2.7 \text{ V}$				20	20	
		$V_O = 0.4 \text{ V}$				-20	-20	
I_I	$V_{CC} = \text{MAX}, V_I = 7 \text{ V}$			0.1		0.1	mA	
I_{IH}	$V_{CC} = \text{MAX}, V_I = 2.7 \text{ V}$			20		20	μA	
I_{IL}	Enable \bar{G} All other	$V_{CC} = \text{MAX}, V_I = 0.4$				-0.2	-0.2	
						-0.4	-0.4	
$I_{OS}§$	$V_{CC} = \text{MAX}$	-30		-130		-30	-130	mA
I_{CC}	$V_{CC} = \text{MAX},$ See Note 3	Condition A		6.1	10	6.1	10	
		Condition B		7.1	12	7.1	12	

† For conditions shown as MIN or MAX, use the appropriate value specified under recommended operating conditions for the applicable type.

‡ All typical values are at $V_{CC} = 5 \text{ V}, T_A = 25^\circ\text{C}$.

§ Not more than one output should be shorted at a time, and duration of the short-circuit should not exceed one second.

NOTE 3: I_{CC} is measured with the outputs open and all data and select inputs at 4.5 V under the following conditions:

- A. Enable grounded.
- B. Strobe at 4.5 V.

**SN54LS251 SN74LS251, (TIM9905),
 DATA SELECTORS/MULTIPLEXERS WITH 3-STATE OUTPUTS**

SDLS085 - DECEMBER 1972 - REVISED MARCH 1988

switching characteristics, $V_{CC} = 5\text{ V}$, $T_A = 25^\circ\text{C}$

PARAMETER†	FROM (INPUT)	TO (OUTPUT)	TEST CONDITIONS	MIN	TYP	MAX	UNIT
t_{PLH}	A, B, or C (4 levels)	Y	$C_L = 15\text{ pF}$, $R_L = 2\text{ k}\Omega$, See Note 2		29	45	ns
t_{PHL}					28	45	
t_{PLH}	A, B, or C (3 levels)	W			20	33	ns
t_{PHL}					21	33	
t_{PLH}	Any D	Y			17	28	ns
t_{PHL}					18	28	
t_{PLH}	Any D	W			10	15	ns
t_{PHL}					9	15	
t_{PZH}	\bar{G}	Y			30	45	ns
t_{PZL}					26	40	
t_{PZH}	\bar{G}	W		17	27	ns	
t_{PZL}				24	40		
t_{PHZ}	\bar{G}	Y	$C_L = 5\text{ pF}$, $R_L = 2\text{ k}\Omega$, See Note 2		30	45	ns
t_{PLZ}					15	25	
t_{PHZ}	\bar{G}	W			37	55	ns
t_{PLZ}					15	25	

- † t_{PLH} = Propagation delay time, low-to-high-level output
- t_{PHL} = Propagation delay time, high-to-low-level output
- t_{PZH} = Output enable time to high level
- t_{PZL} = Output enable time to low level
- t_{PHZ} = Output disable time from high level
- t_{PLZ} = Output disable time from low level

NOTE 2: Load circuits and voltage waveforms are shown in Section 1.

schematics of inputs and outputs

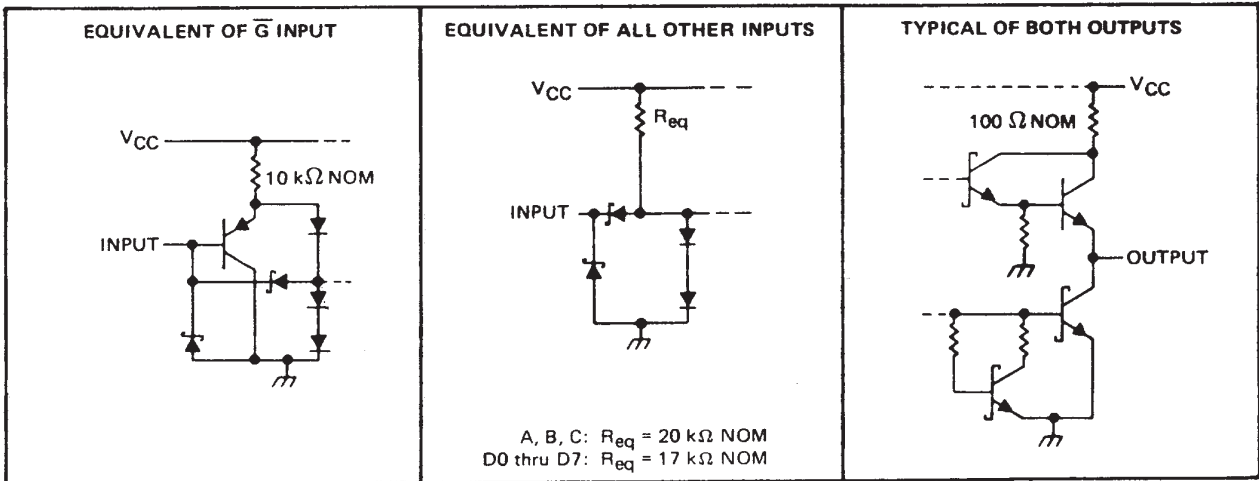

SN54S251 SN74S251, DATA SELECTORS/MULTIPLEXERS WITH 3-STATE OUTPUTS

SDLS085 – DECEMBER 1972 – REVISED MARCH 1988

absolute maximum ratings over operating free-air temperature range (unless otherwise noted)

Supply voltage, V_{CC} (see Note 1)	7 V
Input voltage	5.5 V
Off-state output voltage	5.5 V
Operating free-air temperature range: SN54S251	-55°C to 125°C
SN74S251	0°C to 70°C
Storage temperature range	-65°C to 150°C

NOTE 1: Voltage values are with respect to network ground terminal.

recommended operating conditions

	SN54S251			SN74S251			UNIT
	MIN	NOM	MAX	MIN	NOM	MAX	
Supply voltage, V_{CC}	4.5	5	5.5	4.75	5	5.25	V
High-level output current, I_{OH}			-2			-6.5	mA
Low-level output current, I_{OL}			20			20	mA
Operating free-air temperature, T_A	-55		125	0		70	°C

electrical characteristics over recommended operating free-air temperature range (unless otherwise noted)

PARAMETER	TEST CONDITIONS [†]	MIN	TYP [‡]	MAX	UNIT
V_{IH} High-level input voltage		2			V
V_{IL} Low-level input voltage				0.8	V
V_{IK} Input clamp voltage	$V_{CC} = \text{MIN}, I_I = -18 \text{ mA}$			-1.2	V
V_{OH} High-level output voltage	$V_{CC} = \text{MIN}, V_{IH} = 2 \text{ V},$ $V_{IL} = 0.8 \text{ V}, I_{OH} = \text{MAX}$	SN54S'	2.4	3.4	V
		SN74S'	2.4	3.2	
V_{OL} Low-level output voltage	$V_{CC} = \text{MIN}, V_{IH} = 2 \text{ V},$ $V_{IL} = 0.8 \text{ V}, I_{OL} = 20 \text{ mA}$			0.5	V
I_{OZ} Off-state (high-impedance-state) output current	$V_{CC} = \text{MAX}, V_{IH} = 2 \text{ V}$	$V_O = 2.4 \text{ V}$		50	μA
		$V_O = 0.5 \text{ V}$		-50	
I_I Input current at maximum input voltage	$V_{CC} = \text{MAX}, V_I = 5.5 \text{ V}$			1	mA
I_{IH} High-level input current	$V_{CC} = \text{MAX}, V_I = 2.7 \text{ V}$			50	μA
I_{IL} Low-level input current	$V_{CC} = \text{MAX}, V_I = 0.5 \text{ V}$			-2	mA
I_{OS} Short-circuit output current [§]	$V_{CC} = \text{MAX}$	-40		-100	mA
I_{CC} Supply current	$V_{CC} = \text{MAX},$ All inputs at 4.5 V, All outputs open		55	85	mA

[†] For conditions shown as MIN or MAX, use the appropriate value specified under recommended operating conditions for the applicable type.

[‡] All typical values are at $V_{CC} = 5 \text{ V}, T_A = 25^\circ\text{C}$.

[§] Not more than one output should be shorted at a time, and duration of the short-circuit should not exceed one second.

**SN54S251 SN74S251,
 DATA SELECTORS/MULTIPLEXERS WITH 3-STATE OUTPUTS**

SDLS085 – DECEMBER 1972 – REVISED MARCH 1988

switching characteristics, $V_{CC} = 5\text{ V}$, $T_A = 25^\circ\text{C}$

PARAMETER†	FROM (INPUT)	TO (OUTPUT)	TEST CONDITIONS	MIN	TYP	MAX	UNIT	
t_{PLH}	A, B, or C (4 levels)	Y	$C_L = 15\text{ pF}$, $R_L = 280\ \Omega$, See Note 2		12	18	ns	
t_{PHL}					13	19.5		
t_{PLH}	A, B, or C (3 levels)	W			10	15	ns	
t_{PHL}					9	13.5		
t_{PLH}	Any D	Y			8	12	ns	
t_{PHL}					8	12		
t_{PLH}	Any D	W			4.5	7	ns	
t_{PHL}					4.5	7		
t_{PZH}	\bar{G}	Y		$C_L = 50\text{ pF}$, $R_L = 280\ \Omega$, See Note 2		13	19.5	ns
t_{PZL}						14	21	
t_{PZH}	\bar{G}	W			13	19.5	ns	
t_{PZL}					14	21		
t_{PHZ}	\bar{G}	Y	$C_L = 5\text{ pF}$, $R_L = 280\ \Omega$, See Note 2			5.5	8.5	ns
t_{PLZ}						9	14	
t_{PHZ}	\bar{G}	W			5.5	8.5	ns	
t_{PLZ}					9	14		

† t_{PLH} = Propagation delay time, low-to-high-level output
 t_{PHL} = Propagation delay time, high-to-low-level output
 t_{PZH} = Output enable time to high level
 t_{PZL} = Output enable time to low level
 t_{PHZ} = Output disable time from high level
 t_{PLZ} = Output disable time from low level

NOTE 2: Load circuits and voltage waveforms are shown in Section 1.

schematics of inputs and outputs

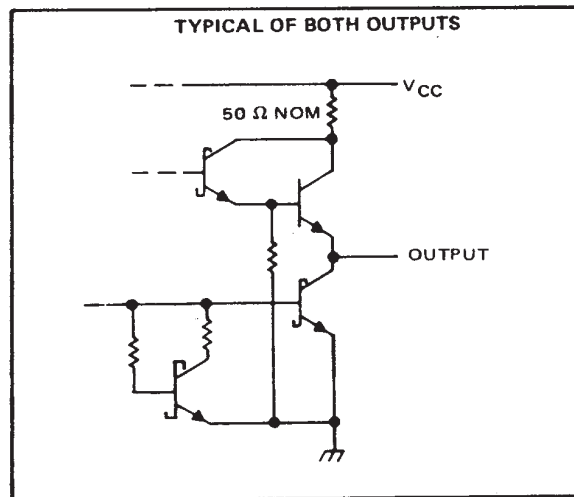
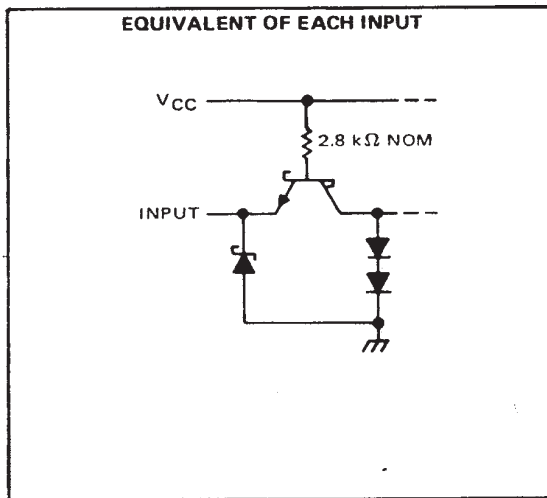

PACKAGING INFORMATION

Orderable Device	Status (1)	Package Type	Package Drawing	Pins	Package Qty	Eco Plan (2)	Lead/Ball Finish (6)	MSL Peak Temp (3)	Op Temp (°C)	Device Marking (4/5)	Samples
7601601EA	ACTIVE	CDIP	J	16	1	TBD	A42	N / A for Pkg Type	-55 to 125	7601601EA SNJ54LS251J	Samples
7601601FA	ACTIVE	CFP	W	16	1	TBD	A42	N / A for Pkg Type	-55 to 125	7601601FA SNJ54LS251W	Samples
7601601FA	ACTIVE	CFP	W	16	1	TBD	A42	N / A for Pkg Type	-55 to 125	7601601FA SNJ54LS251W	Samples
8002201EA	OBSOLETE	CDIP	J	16		TBD	Call TI	Call TI	-55 to 125		
8002201EA	OBSOLETE	CDIP	J	16		TBD	Call TI	Call TI	-55 to 125		
8002201FA	OBSOLETE	CFP	W	16		TBD	Call TI	Call TI	-55 to 125		
8002201FA	OBSOLETE	CFP	W	16		TBD	Call TI	Call TI	-55 to 125		
JM38510/07905BEA	OBSOLETE	CDIP	J	16		TBD	Call TI	Call TI	-55 to 125		
JM38510/07905BEA	OBSOLETE	CDIP	J	16		TBD	Call TI	Call TI	-55 to 125		
JM38510/30905BEA	ACTIVE	CDIP	J	16	1	TBD	A42	N / A for Pkg Type	-55 to 125	JM38510/ 30905BEA	Samples
JM38510/30905BEA	ACTIVE	CDIP	J	16	1	TBD	A42	N / A for Pkg Type	-55 to 125	JM38510/ 30905BEA	Samples
M38510/30905BEA	ACTIVE	CDIP	J	16	1	TBD	A42	N / A for Pkg Type	-55 to 125	JM38510/ 30905BEA	Samples
M38510/30905BEA	ACTIVE	CDIP	J	16	1	TBD	A42	N / A for Pkg Type	-55 to 125	JM38510/ 30905BEA	Samples
SN54251J	OBSOLETE	CDIP	J	16		TBD	Call TI	Call TI	-55 to 125		
SN54251J	OBSOLETE	CDIP	J	16		TBD	Call TI	Call TI	-55 to 125		
SN54LS251J	ACTIVE	CDIP	J	16	1	TBD	A42	N / A for Pkg Type	-55 to 125	SN54LS251J	Samples
SN54LS251J	ACTIVE	CDIP	J	16	1	TBD	A42	N / A for Pkg Type	-55 to 125	SN54LS251J	Samples
SN54S251J	OBSOLETE	CDIP	J	16		TBD	Call TI	Call TI	-55 to 125		
SN54S251J	OBSOLETE	CDIP	J	16		TBD	Call TI	Call TI	-55 to 125		
SN74251N	OBSOLETE	PDIP	N	16		TBD	Call TI	Call TI	0 to 70		
SN74251N	OBSOLETE	PDIP	N	16		TBD	Call TI	Call TI	0 to 70		
SN74251N3	OBSOLETE	PDIP	N	16		TBD	Call TI	Call TI	0 to 70		
SN74251N3	OBSOLETE	PDIP	N	16		TBD	Call TI	Call TI	0 to 70		



Distributor of Texas Instruments: Excellent Integrated System Limited

Datasheet of SN74LS251DR - IC 8-TO-1 LINE SEL/MUX 16-SOIC

Contact us: sales@integrated-circuit.com Website: www.integrated-circuit.com

PACKAGE OPTION ADDENDUM

www.ti.com

17-Dec-2015

Orderable Device	Status (1)	Package Type	Package Drawing	Pins	Package Qty	Eco Plan (2)	Lead/Ball Finish (6)	MSL Peak Temp (3)	Op Temp (°C)	Device Marking (4/5)	Samples
SN74LS251D	ACTIVE	SOIC	D	16	40	Green (RoHS & no Sb/Br)	CU NIPDAU	Level-1-260C-UNLIM	0 to 70	LS251	Samples
SN74LS251D	ACTIVE	SOIC	D	16	40	Green (RoHS & no Sb/Br)	CU NIPDAU	Level-1-260C-UNLIM	0 to 70	LS251	Samples
SN74LS251DR	ACTIVE	SOIC	D	16	2500	Green (RoHS & no Sb/Br)	CU NIPDAU	Level-1-260C-UNLIM	0 to 70	LS251	Samples
SN74LS251DR	ACTIVE	SOIC	D	16	2500	Green (RoHS & no Sb/Br)	CU NIPDAU	Level-1-260C-UNLIM	0 to 70	LS251	Samples
SN74LS251N	ACTIVE	PDIP	N	16	25	Pb-Free (RoHS)	CU NIPDAU	N / A for Pkg Type	0 to 70	SN74LS251N	Samples
SN74LS251N	ACTIVE	PDIP	N	16	25	Pb-Free (RoHS)	CU NIPDAU	N / A for Pkg Type	0 to 70	SN74LS251N	Samples
SN74LS251N3	OBSOLETE	PDIP	N	16		TBD	Call TI	Call TI	0 to 70		
SN74LS251N3	OBSOLETE	PDIP	N	16		TBD	Call TI	Call TI	0 to 70		
SN74LS251NE4	ACTIVE	PDIP	N	16	25	Pb-Free (RoHS)	CU NIPDAU	N / A for Pkg Type	0 to 70	SN74LS251N	Samples
SN74LS251NE4	ACTIVE	PDIP	N	16	25	Pb-Free (RoHS)	CU NIPDAU	N / A for Pkg Type	0 to 70	SN74LS251N	Samples
SN74LS251NSR	ACTIVE	SO	NS	16	2000	Green (RoHS & no Sb/Br)	CU NIPDAU	Level-1-260C-UNLIM	0 to 70	74LS251	Samples
SN74LS251NSR	ACTIVE	SO	NS	16	2000	Green (RoHS & no Sb/Br)	CU NIPDAU	Level-1-260C-UNLIM	0 to 70	74LS251	Samples
SN74S251D	OBSOLETE	SOIC	D	16		TBD	Call TI	Call TI	0 to 70		
SN74S251D	OBSOLETE	SOIC	D	16		TBD	Call TI	Call TI	0 to 70		
SN74S251N	OBSOLETE	PDIP	N	16		TBD	Call TI	Call TI	0 to 70		
SN74S251N	OBSOLETE	PDIP	N	16		TBD	Call TI	Call TI	0 to 70		
SN74S251N3	OBSOLETE	PDIP	N	16		TBD	Call TI	Call TI	0 to 70		
SN74S251N3	OBSOLETE	PDIP	N	16		TBD	Call TI	Call TI	0 to 70		
SNJ54251J	OBSOLETE	CDIP	J	16		TBD	Call TI	Call TI	-55 to 125		
SNJ54251J	OBSOLETE	CDIP	J	16		TBD	Call TI	Call TI	-55 to 125		
SNJ54LS251FK	ACTIVE	LCCC	FK	20	1	TBD	POST-PLATE	N / A for Pkg Type	-55 to 125	SNJ54LS251FK	Samples
SNJ54LS251FK	ACTIVE	LCCC	FK	20	1	TBD	POST-PLATE	N / A for Pkg Type	-55 to 125	SNJ54LS251FK	Samples

Orderable Device	Status (1)	Package Type	Package Drawing	Pins	Package Qty	Eco Plan (2)	Lead/Ball Finish (6)	MSL Peak Temp (3)	Op Temp (°C)	Device Marking (4/5)	Samples
SNJ54LS251J	ACTIVE	CDIP	J	16	1	TBD	A42	N / A for Pkg Type	-55 to 125	7601601EA SNJ54LS251J	Samples
SNJ54LS251J	ACTIVE	CDIP	J	16	1	TBD	A42	N / A for Pkg Type	-55 to 125	7601601EA SNJ54LS251J	Samples
SNJ54LS251W	ACTIVE	CFP	W	16	1	TBD	A42	N / A for Pkg Type	-55 to 125	7601601FA SNJ54LS251W	Samples
SNJ54LS251W	ACTIVE	CFP	W	16	1	TBD	A42	N / A for Pkg Type	-55 to 125	7601601FA SNJ54LS251W	Samples
SNJ54S251FK	OBSOLETE	LCCC	FK	20		TBD	Call TI	Call TI	-55 to 125		
SNJ54S251FK	OBSOLETE	LCCC	FK	20		TBD	Call TI	Call TI	-55 to 125		
SNJ54S251J	OBSOLETE	CDIP	J	16		TBD	Call TI	Call TI	-55 to 125		
SNJ54S251J	OBSOLETE	CDIP	J	16		TBD	Call TI	Call TI	-55 to 125		
SNJ54S251W	OBSOLETE	CFP	W	16		TBD	Call TI	Call TI	-55 to 125		
SNJ54S251W	OBSOLETE	CFP	W	16		TBD	Call TI	Call TI	-55 to 125		

(1) The marketing status values are defined as follows:

ACTIVE: Product device recommended for new designs.

LIFEBUY: TI has announced that the device will be discontinued, and a lifetime-buy period is in effect.

NRND: Not recommended for new designs. Device is in production to support existing customers, but TI does not recommend using this part in a new design.

PREVIEW: Device has been announced but is not in production. Samples may or may not be available.

OBSOLETE: TI has discontinued the production of the device.

(2) Eco Plan - The planned eco-friendly classification: Pb-Free (RoHS), Pb-Free (RoHS Exempt), or Green (RoHS & no Sb/Br) - please check <http://www.ti.com/productcontent> for the latest availability information and additional product content details.

TBD: The Pb-Free/Green conversion plan has not been defined.

Pb-Free (RoHS): TI's terms "Lead-Free" or "Pb-Free" mean semiconductor products that are compatible with the current RoHS requirements for all 6 substances, including the requirement that lead not exceed 0.1% by weight in homogeneous materials. Where designed to be soldered at high temperatures, TI Pb-Free products are suitable for use in specified lead-free processes.

Pb-Free (RoHS Exempt): This component has a RoHS exemption for either 1) lead-based flip-chip solder bumps used between the die and package, or 2) lead-based die adhesive used between the die and leadframe. The component is otherwise considered Pb-Free (RoHS compatible) as defined above.

Green (RoHS & no Sb/Br): TI defines "Green" to mean Pb-Free (RoHS compatible), and free of Bromine (Br) and Antimony (Sb) based flame retardants (Br or Sb do not exceed 0.1% by weight in homogeneous material)

(3) MSL, Peak Temp. - The Moisture Sensitivity Level rating according to the JEDEC industry standard classifications, and peak solder temperature.

(4) There may be additional marking, which relates to the logo, the lot trace code information, or the environmental category on the device.



⁽⁶⁾ Multiple Device Markings will be inside parentheses. Only one Device Marking contained in parentheses and separated by a "-" will appear on a device. If a line is indented then it is a continuation of the previous line and the two combined represent the entire Device Marking for that device.

⁽⁶⁾ Lead/Ball Finish - Orderable Devices may have multiple material finish options. Finish options are separated by a vertical ruled line. Lead/Ball Finish values may wrap to two lines if the finish value exceeds the maximum column width.

Important Information and Disclaimer: The information provided on this page represents TI's knowledge and belief as of the date that it is provided. TI bases its knowledge and belief on information provided by third parties, and makes no representation or warranty as to the accuracy of such information. Efforts are underway to better integrate information from third parties. TI has taken and continues to take reasonable steps to provide representative and accurate information but may not have conducted destructive testing or chemical analysis on incoming materials and chemicals. TI and TI suppliers consider certain information to be proprietary, and thus CAS numbers and other limited information may not be available for release.

In no event shall TI's liability arising out of such information exceed the total purchase price of the TI part(s) at issue in this document sold by TI to Customer on an annual basis.

OTHER QUALIFIED VERSIONS OF SN54251, SN54LS251, SN54S251, SN74251, SN74LS251, SN74S251 :

● Catalog: [SN74251](#), [SN74LS251](#), [SN74S251](#)

● Military: [SN54251](#), [SN54LS251](#), [SN54S251](#)

NOTE: Qualified Version Definitions:

- Catalog - TI's standard catalog product
- Military - QML certified for Military and Defense Applications

TAPE AND REEL INFORMATION

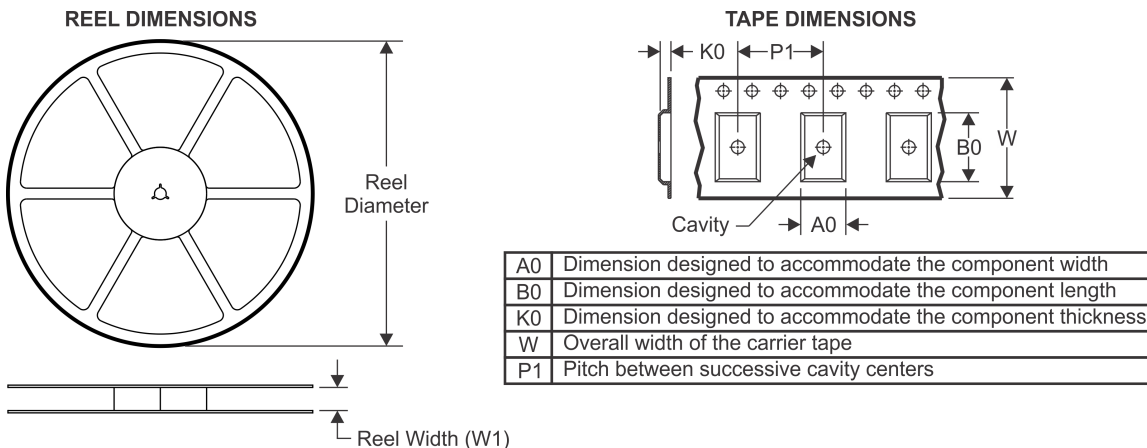

QUADRANT ASSIGNMENTS FOR PIN 1 ORIENTATION IN TAPE

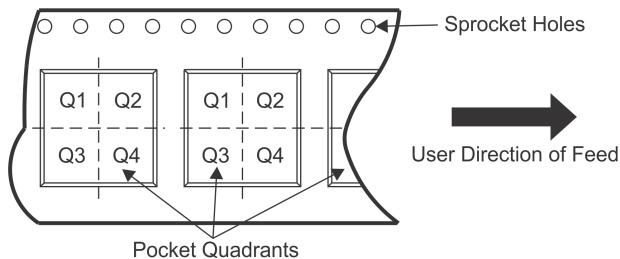

*All dimensions are nominal

Device	Package Type	Package Drawing	Pins	SPQ	Reel Diameter (mm)	Reel Width W1 (mm)	A0 (mm)	B0 (mm)	K0 (mm)	P1 (mm)	W (mm)	Pin1 Quadrant
SN74LS251DR	SOIC	D	16	2500	330.0	16.4	6.5	10.3	2.1	8.0	16.0	Q1

TAPE AND REEL BOX DIMENSIONS

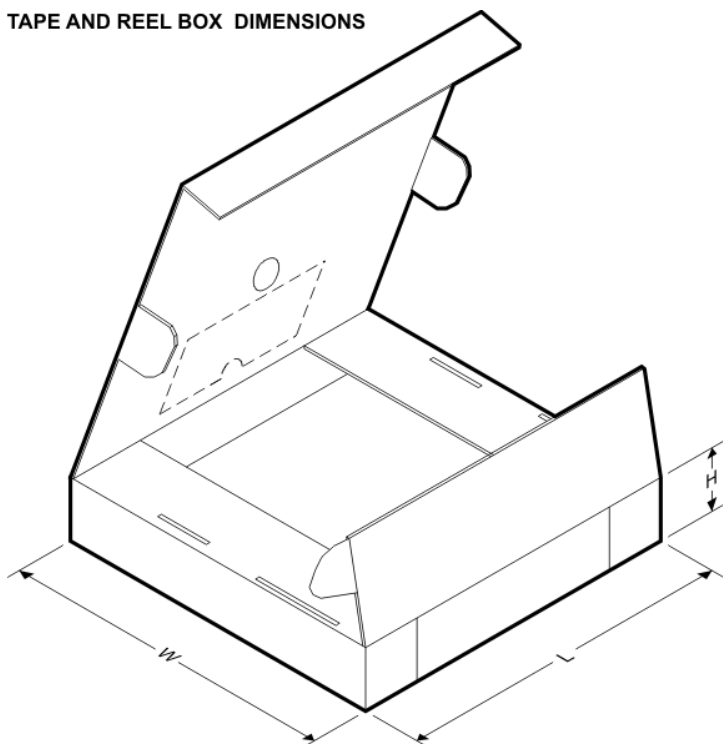

*All dimensions are nominal

Device	Package Type	Package Drawing	Pins	SPQ	Length (mm)	Width (mm)	Height (mm)
SN74LS251DR	SOIC	D	16	2500	333.2	345.9	28.6

J (R-GDIP-T**)

14 LEADS SHOWN

CERAMIC DUAL IN-LINE PACKAGE

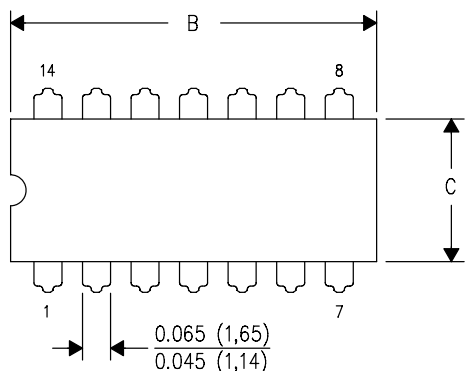

DIM \ PINS **	14	16	18	20
A	0.300 (7,62) BSC	0.300 (7,62) BSC	0.300 (7,62) BSC	0.300 (7,62) BSC
B MAX	0.785 (19,94)	.840 (21,34)	0.960 (24,38)	1.060 (26,92)
B MIN	—	—	—	—
C MAX	0.300 (7,62)	0.300 (7,62)	0.310 (7,87)	0.300 (7,62)
C MIN	0.245 (6,22)	0.245 (6,22)	0.220 (5,59)	0.245 (6,22)

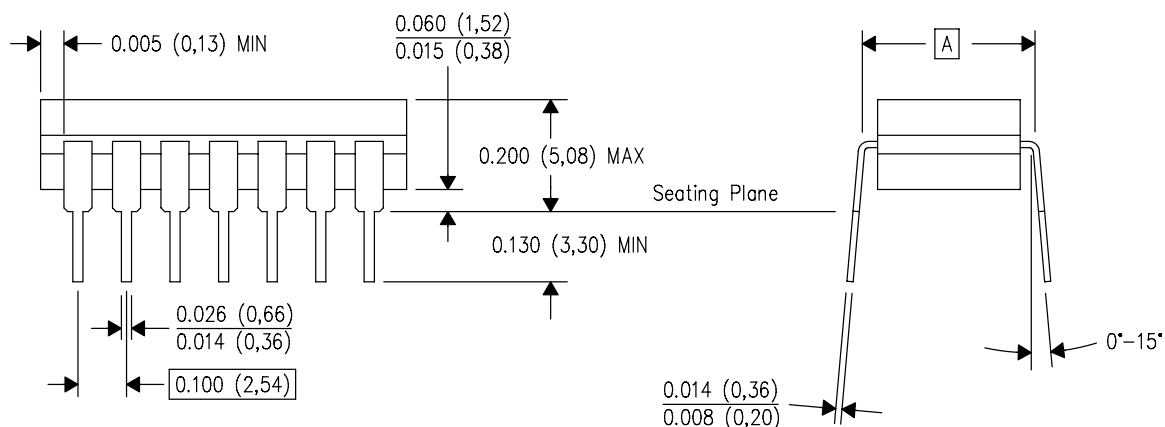

4040083/F 03/03

- NOTES:
- A. All linear dimensions are in inches (millimeters).
 - B. This drawing is subject to change without notice.
 - C. This package is hermetically sealed with a ceramic lid using glass frit.
 - D. Index point is provided on cap for terminal identification only on press ceramic glass frit seal only.
 - E. Falls within MIL STD 1835 GDIP1-T14, GDIP1-T16, GDIP1-T18 and GDIP1-T20.

MECHANICAL DATA

W (R-GDFP-F16)

CERAMIC DUAL FLATPACK

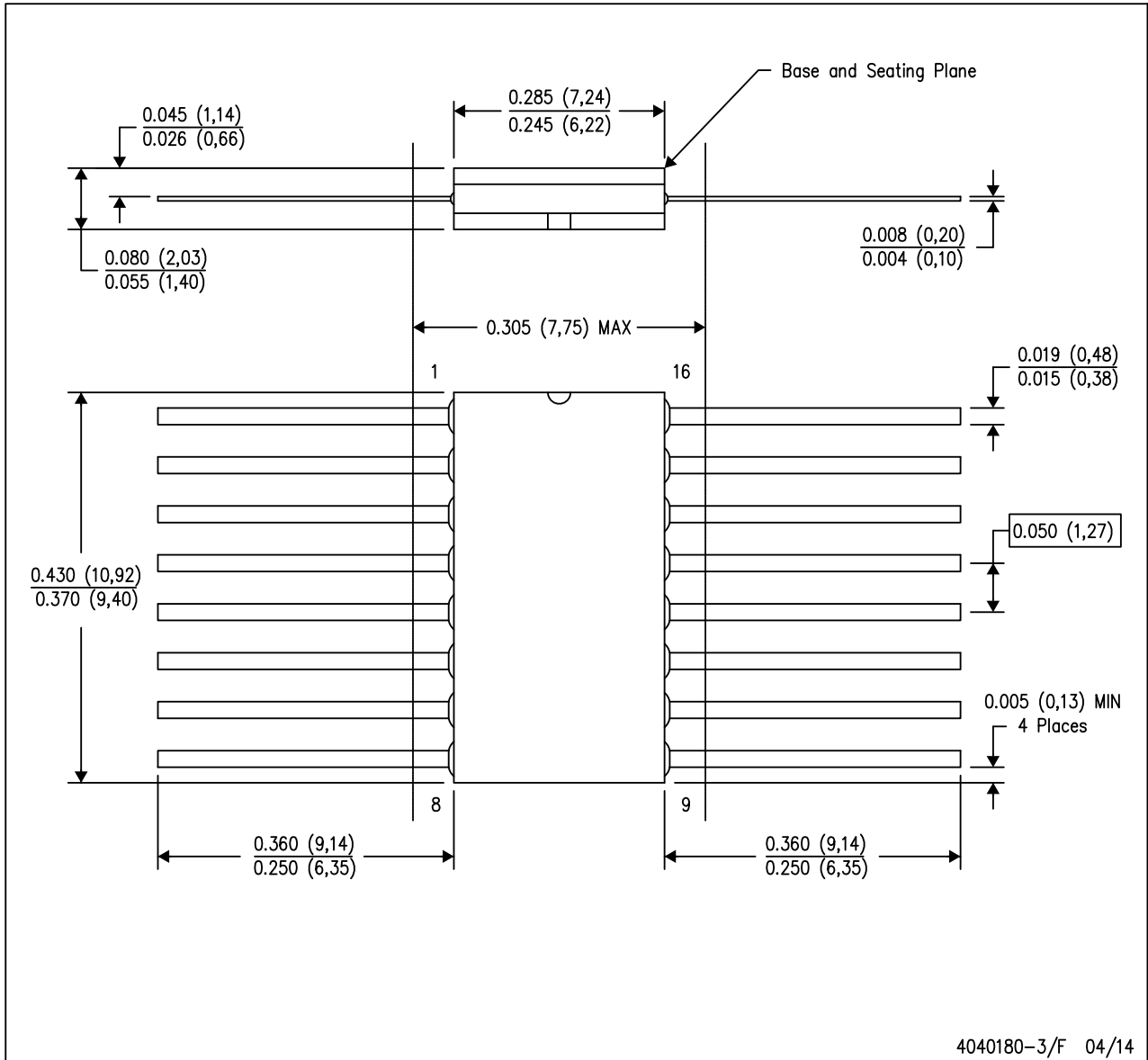

- NOTES:
- A. All linear dimensions are in inches (millimeters).
 - B. This drawing is subject to change without notice.
 - C. This package can be hermetically sealed with a ceramic lid using glass frit.
 - D. Index point is provided on cap for terminal identification only.
 - E. Falls within MIL STD 1835 GDFP2-F16

FK (S-CQCC-N**)

LEADLESS CERAMIC CHIP CARRIER

28 TERMINAL SHOWN

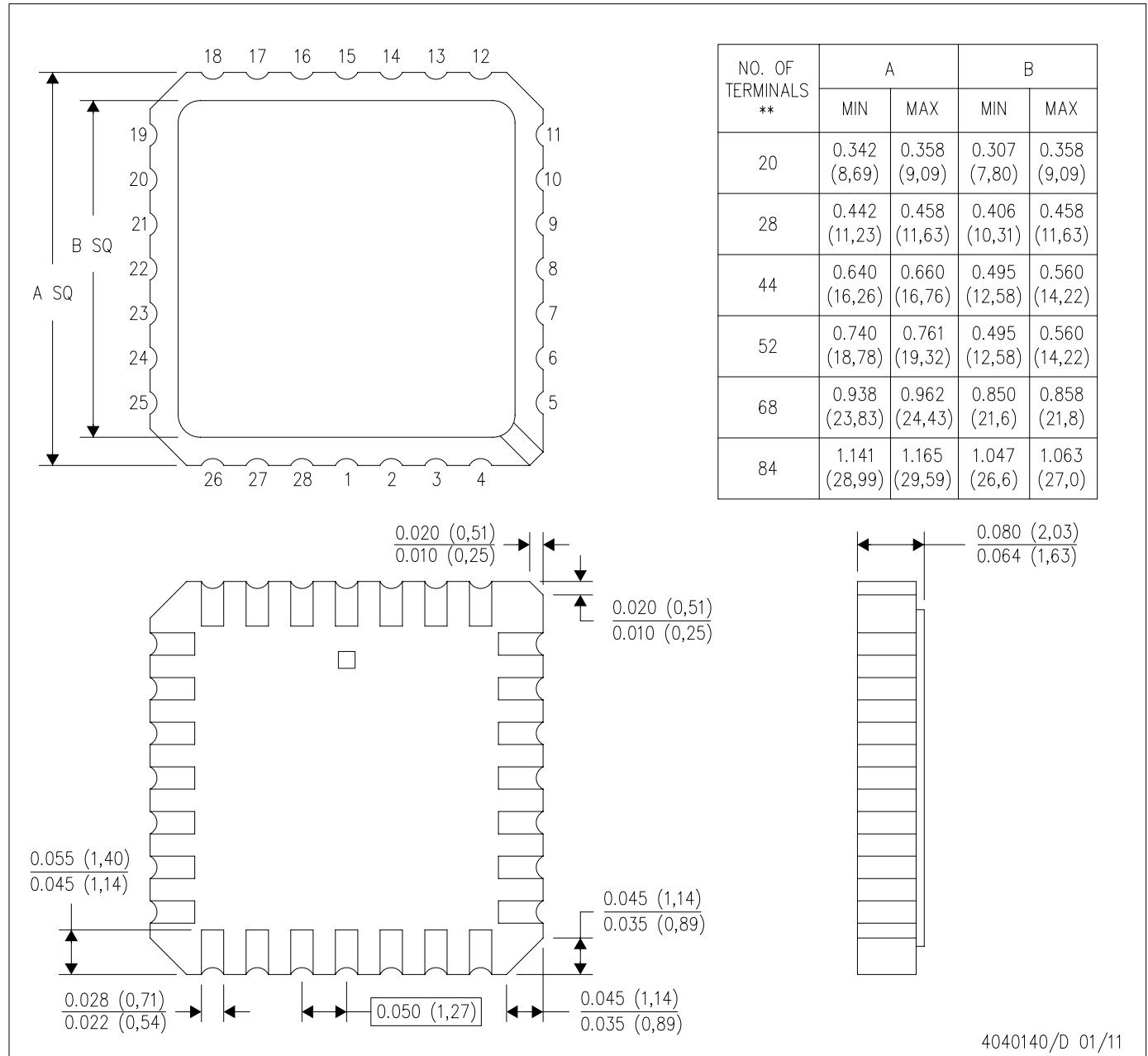

4040140/D 01/11

- NOTES:
- All linear dimensions are in inches (millimeters).
 - This drawing is subject to change without notice.
 - This package can be hermetically sealed with a metal lid.
 - Falls within JEDEC MS-004

MECHANICAL DATA

N (R-PDIP-T)**

16 PINS SHOWN

PLASTIC DUAL-IN-LINE PACKAGE

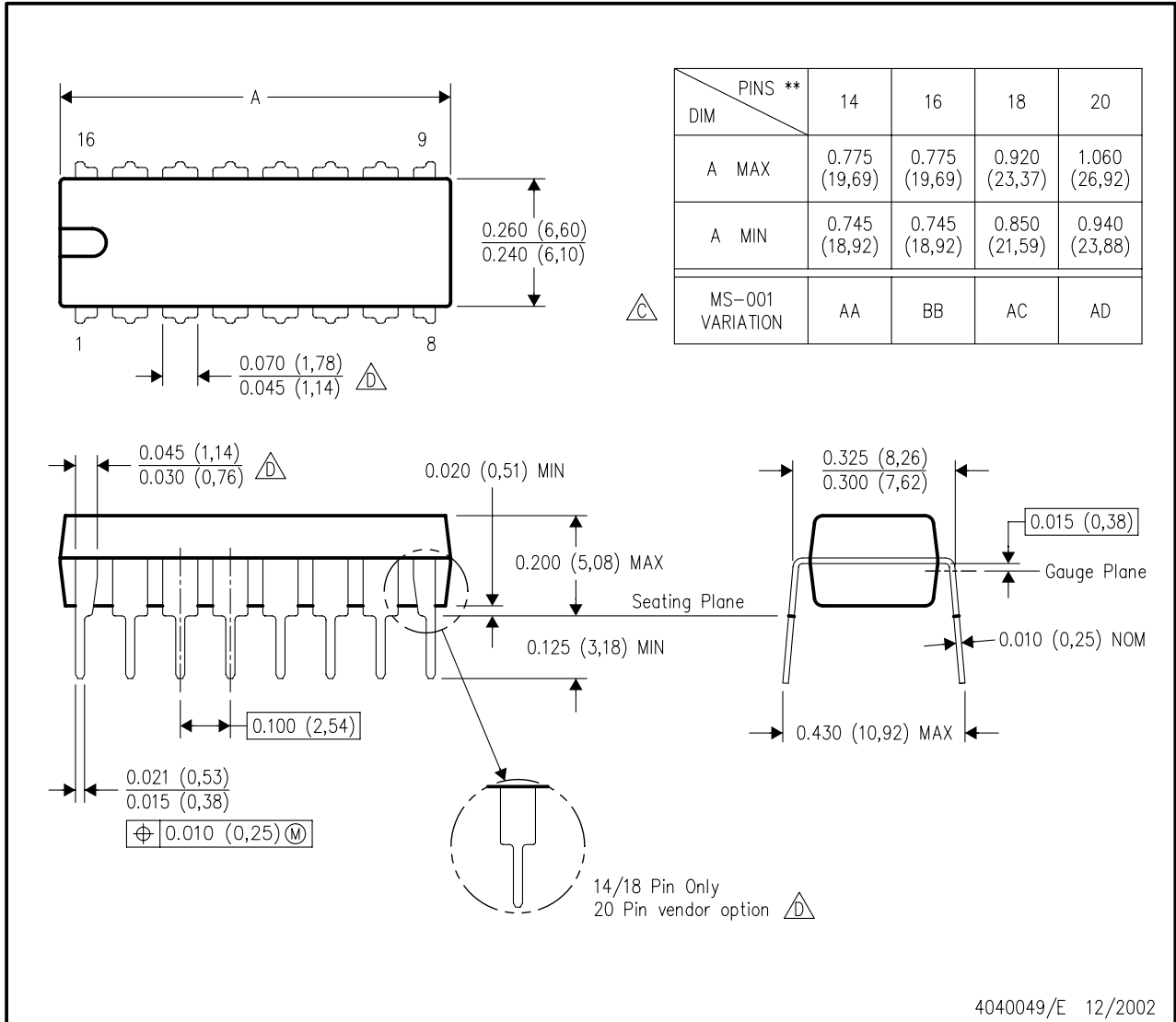

4040049/E 12/2002

- NOTES:
- A. All linear dimensions are in inches (millimeters).
 - B. This drawing is subject to change without notice.
 - Falls within JEDEC MS-001, except 18 and 20 pin minimum body length (Dim A).
 - The 20 pin end lead shoulder width is a vendor option, either half or full width.

MECHANICAL DATA

D (R-PDSO-G16)

PLASTIC SMALL OUTLINE

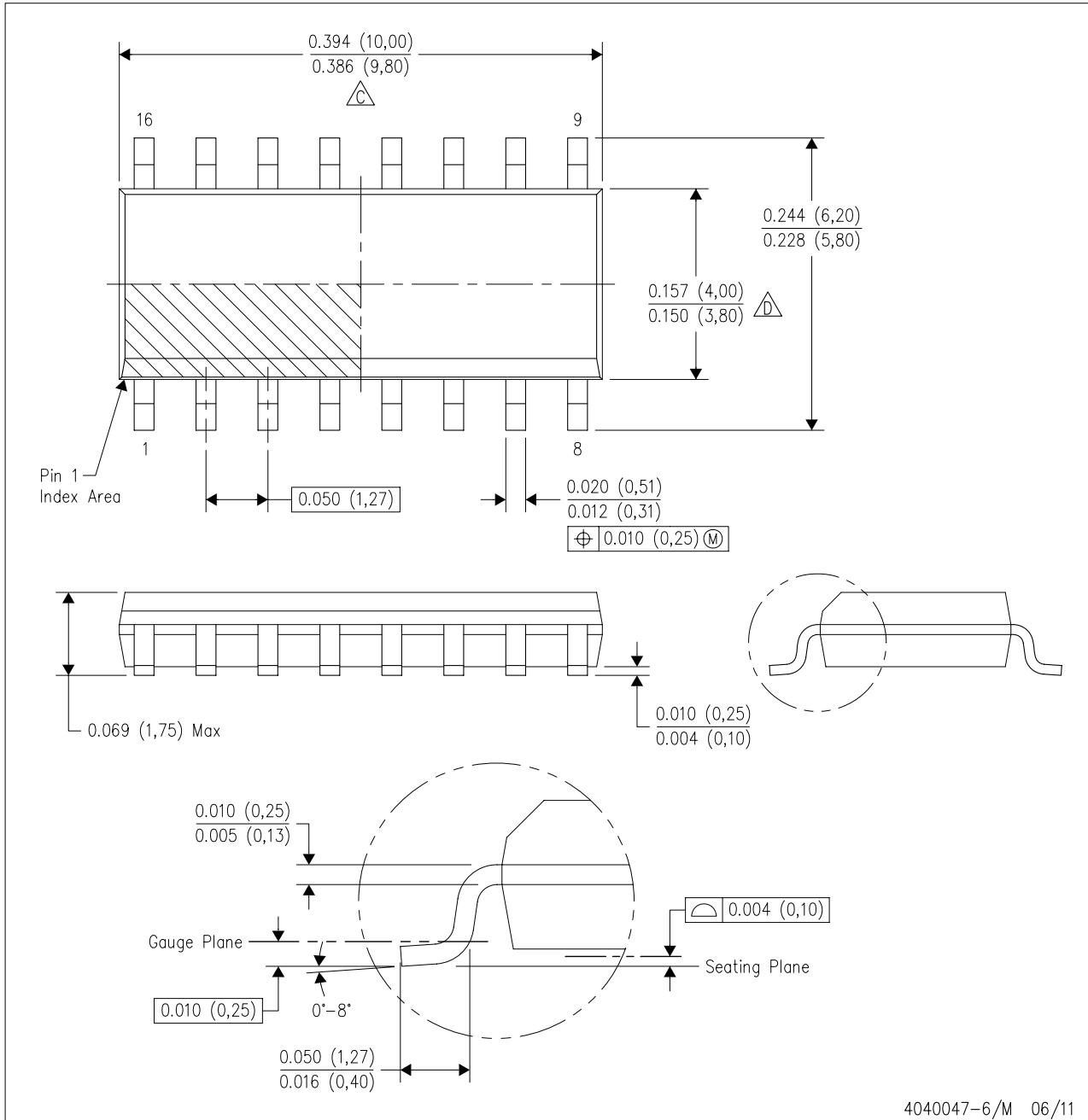

4040047-6/M 06/11

- NOTES:
- A. All linear dimensions are in inches (millimeters).
 - B. This drawing is subject to change without notice.
 - $\triangle C$ Body length does not include mold flash, protrusions, or gate burrs. Mold flash, protrusions, or gate burrs shall not exceed 0.006 (0,15) each side.
 - $\triangle D$ Body width does not include interlead flash. Interlead flash shall not exceed 0.017 (0,43) each side.
 - E. Reference JEDEC MS-012 variation AC.

LAND PATTERN DATA

D (R-PDSO-G16)

PLASTIC SMALL OUTLINE

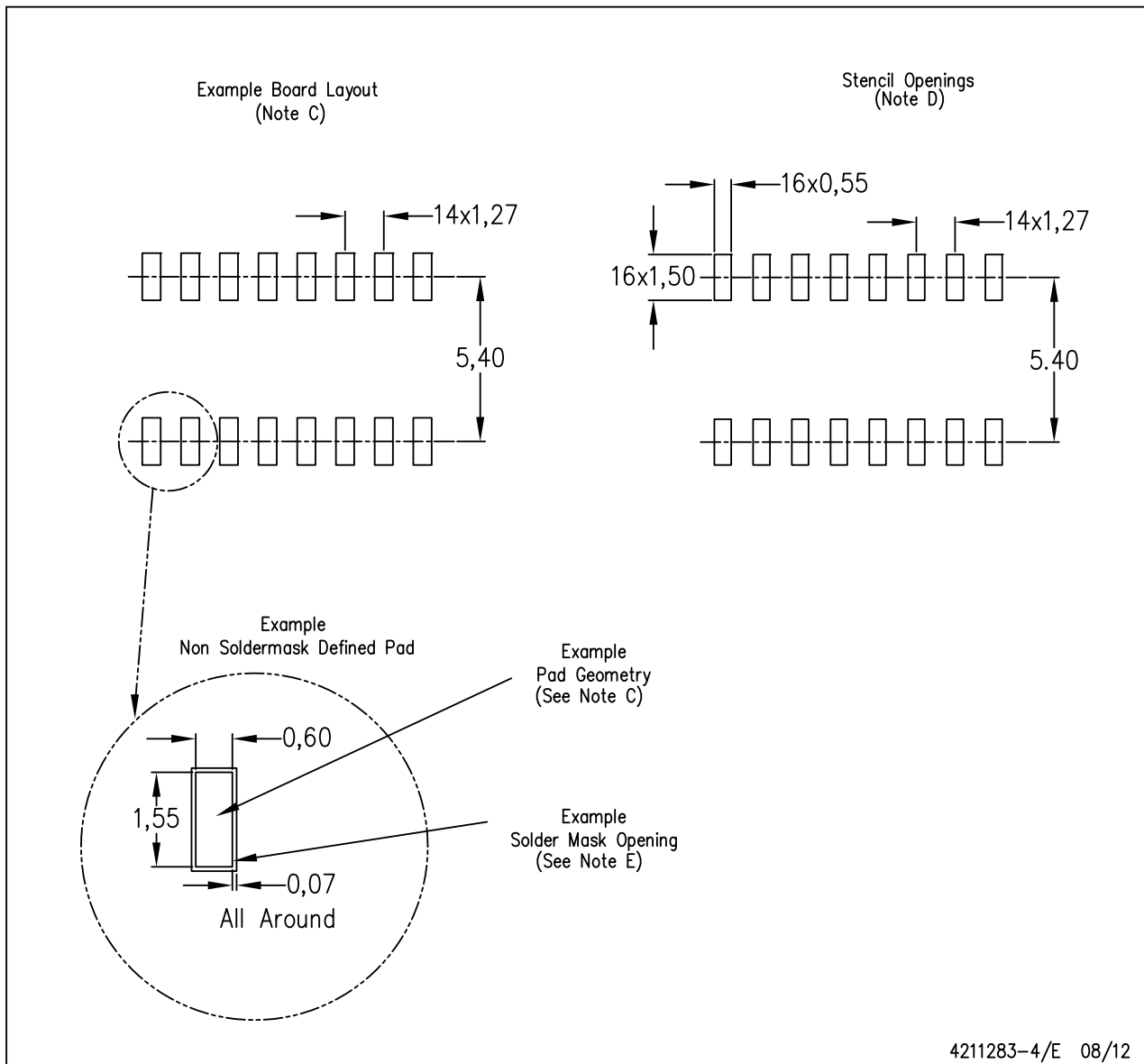

- NOTES:
- All linear dimensions are in millimeters.
 - This drawing is subject to change without notice.
 - Publication IPC-7351 is recommended for alternate designs.
 - Laser cutting apertures with trapezoidal walls and also rounding corners will offer better paste release. Customers should contact their board assembly site for stencil design recommendations. Refer to IPC-7525 for other stencil recommendations.
 - Customers should contact their board fabrication site for solder mask tolerances between and around signal pads.

MECHANICAL DATA

NS (R-PDSO-G)**

PLASTIC SMALL-OUTLINE PACKAGE

14-PINS SHOWN

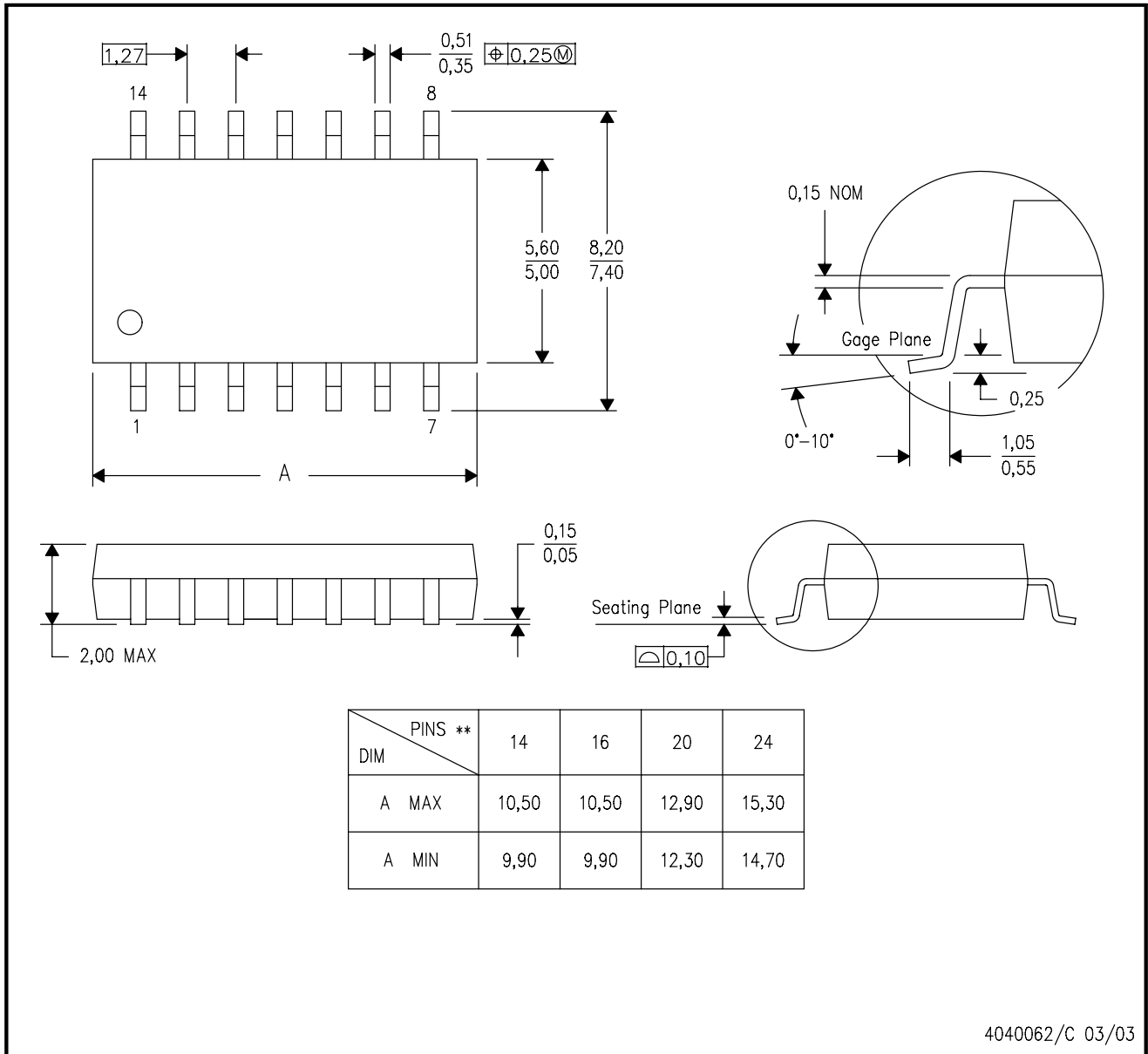

- NOTES:
- A. All linear dimensions are in millimeters.
 - B. This drawing is subject to change without notice.
 - C. Body dimensions do not include mold flash or protrusion, not to exceed 0,15.

IMPORTANT NOTICE

Texas Instruments Incorporated and its subsidiaries (TI) reserve the right to make corrections, enhancements, improvements and other changes to its semiconductor products and services per JESD46, latest issue, and to discontinue any product or service per JESD48, latest issue. Buyers should obtain the latest relevant information before placing orders and should verify that such information is current and complete. All semiconductor products (also referred to herein as "components") are sold subject to TI's terms and conditions of sale supplied at the time of order acknowledgment.

TI warrants performance of its components to the specifications applicable at the time of sale, in accordance with the warranty in TI's terms and conditions of sale of semiconductor products. Testing and other quality control techniques are used to the extent TI deems necessary to support this warranty. Except where mandated by applicable law, testing of all parameters of each component is not necessarily performed.

TI assumes no liability for applications assistance or the design of Buyers' products. Buyers are responsible for their products and applications using TI components. To minimize the risks associated with Buyers' products and applications, Buyers should provide adequate design and operating safeguards.

TI does not warrant or represent that any license, either express or implied, is granted under any patent right, copyright, mask work right, or other intellectual property right relating to any combination, machine, or process in which TI components or services are used. Information published by TI regarding third-party products or services does not constitute a license to use such products or services or a warranty or endorsement thereof. Use of such information may require a license from a third party under the patents or other intellectual property of the third party, or a license from TI under the patents or other intellectual property of TI.

Reproduction of significant portions of TI information in TI data books or data sheets is permissible only if reproduction is without alteration and is accompanied by all associated warranties, conditions, limitations, and notices. TI is not responsible or liable for such altered documentation. Information of third parties may be subject to additional restrictions.

Resale of TI components or services with statements different from or beyond the parameters stated by TI for that component or service voids all express and any implied warranties for the associated TI component or service and is an unfair and deceptive business practice. TI is not responsible or liable for any such statements.

Buyer acknowledges and agrees that it is solely responsible for compliance with all legal, regulatory and safety-related requirements concerning its products, and any use of TI components in its applications, notwithstanding any applications-related information or support that may be provided by TI. Buyer represents and agrees that it has all the necessary expertise to create and implement safeguards which anticipate dangerous consequences of failures, monitor failures and their consequences, lessen the likelihood of failures that might cause harm and take appropriate remedial actions. Buyer will fully indemnify TI and its representatives against any damages arising out of the use of any TI components in safety-critical applications.

In some cases, TI components may be promoted specifically to facilitate safety-related applications. With such components, TI's goal is to help enable customers to design and create their own end-product solutions that meet applicable functional safety standards and requirements. Nonetheless, such components are subject to these terms.

No TI components are authorized for use in FDA Class III (or similar life-critical medical equipment) unless authorized officers of the parties have executed a special agreement specifically governing such use.

Only those TI components which TI has specifically designated as military grade or "enhanced plastic" are designed and intended for use in military/aerospace applications or environments. Buyer acknowledges and agrees that any military or aerospace use of TI components which have **not** been so designated is solely at the Buyer's risk, and that Buyer is solely responsible for compliance with all legal and regulatory requirements in connection with such use.

TI has specifically designated certain components as meeting ISO/TS16949 requirements, mainly for automotive use. In any case of use of non-designated products, TI will not be responsible for any failure to meet ISO/TS16949.

Products

Audio	www.ti.com/audio
Amplifiers	amplifier.ti.com
Data Converters	dataconverter.ti.com
DLP® Products	www.dlp.com
DSP	dsp.ti.com
Clocks and Timers	www.ti.com/clocks
Interface	interface.ti.com
Logic	logic.ti.com
Power Mgmt	power.ti.com
Microcontrollers	microcontroller.ti.com
RFID	www.ti-rfid.com
OMAP Applications Processors	www.ti.com/omap
Wireless Connectivity	www.ti.com/wirelessconnectivity

Applications

Automotive and Transportation	www.ti.com/automotive
Communications and Telecom	www.ti.com/communications
Computers and Peripherals	www.ti.com/computers
Consumer Electronics	www.ti.com/consumer-apps
Energy and Lighting	www.ti.com/energy
Industrial	www.ti.com/industrial
Medical	www.ti.com/medical
Security	www.ti.com/security
Space, Avionics and Defense	www.ti.com/space-avionics-defense
Video and Imaging	www.ti.com/video

TI E2E Community

e2e.ti.com