

Excellent Integrated System Limited

Stocking Distributor

Click to view price, real time Inventory, Delivery & Lifecycle Information:

[TechTools](#)
[ACM-8](#)

For any questions, you can email us directly:

sales@integrated-circuit.com

Active Cable Module - 8 bit Target Interface

Feature Connector - JP6

Control Line 4	1	2	Status Line 4
Control Line 3	3	4	Status Line 3
Control Line 2	5	6	Status Line 2
Control Line 1	7	8	Status Line 1
Trigger Out	9	10	-
Ready Out	11	12	-
Request Out	13	14	Grant
Trigger Ground	15	16	-

EPROM/FLASH Select - JP10

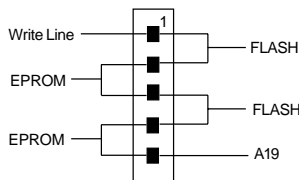

Reset Connector - JP7

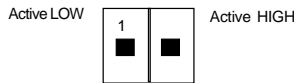

Additional Address Lines - JP11

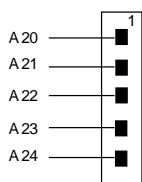

Cable Select - JP8

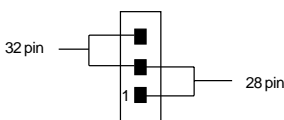

Target Cable Connector - JP9

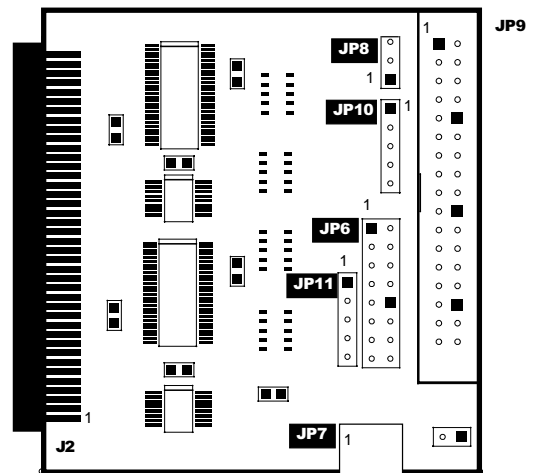

FlexROM III Connector - J2

WARNING:

Never remove or insert the ACM module when power is present. Always remove power from the emulator before changing the ACM module or Target Cable.

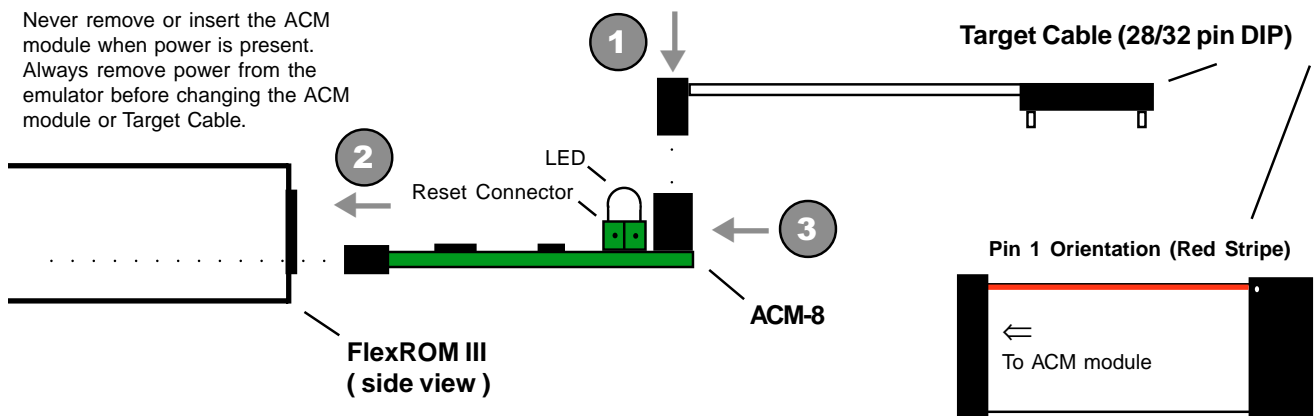

Insertion Instructions:

1. Connect the Target Cable to the ACM module.
2. Insert the ACM module into the open slot provided at the rear of the FlexROM III emulator.
3. Gently slide module into the unit until it stops. Then apply firm pressure until the ACM module seats completely.

(972) 272-9392, FAX: (972) 494-5814, sales@tech-tools.com, http://www.tech-tools.com