

Excellent Integrated System Limited

Stocking Distributor

Click to view price, real time Inventory, Delivery & Lifecycle Information:

[Intersil](#)
[X5643P](#)

For any questions, you can email us directly:
sales@integrated-circuit.com

CPU Supervisor with 64Kbit SPI EEPROM

FEATURES

- Selectable watchdog timer
- Low V_{CC} detection and reset assertion
 - Five standard reset threshold voltages
 - Re-program low V_{CC} reset threshold voltage using special programming sequence
 - Reset signal valid to $V_{CC} = 1V$
- Determine watchdog or low voltage reset with a volatile flag bit
- Long battery life with low power consumption
 - $<50\mu A$ max standby current, watchdog on
 - $<1\mu A$ max standby current, watchdog off
 - $<400\mu A$ max active current during read
- 64Kbits of EEPROM
- Built-in inadvertent write protection
 - Power-up/power-down protection circuitry
 - Protect 0, 1/4, 1/2 or all of EEPROM array with Block Lock™ protection
 - In circuit programmable ROM mode
- 2MHz SPI interface modes (0,0 & 1,1)
- Minimize EEPROM programming time
 - 32-byte page write mode
 - Self-timed write cycle
 - 5ms write cycle time (typical)
- 2.7V to 5.5V and 4.5V to 5.5V power supply operation
- Available packages
 - 8-lead PDIP, 14-lead SOIC

DESCRIPTION

These devices combine four popular functions, Power-on Reset Control, Watchdog Timer, Supply Voltage Supervision, and Block Lock Protect Serial EEPROM Memory in one package. This combination lowers system cost, reduces board space requirements, and increases reliability.

Applying power to the device activates the power-on reset circuit which holds $\overline{RESET}/RESET$ active for a period of time. This allows the power supply and oscillator to stabilize before the processor can execute code.

The Watchdog Timer provides an independent protection mechanism for microcontrollers. When the microcontroller fails to restart a timer within a selectable time out interval, the device activates the $\overline{RESET}/RESET$ signal. The user selects the interval from three preset values. Once selected, the interval does not change, even after cycling the power.

The device's low V_{CC} detection circuitry protects the user's system from low voltage conditions, resetting the system when V_{CC} falls below the minimum V_{CC} trip point. $\overline{RESET}/RESET$ is asserted until V_{CC} returns to proper operating level and stabilizes. Five industry standard V_{TRIP} thresholds are available, however, Intersil's unique circuits allow the threshold to be reprogrammed to meet custom requirements or to fine-tune the threshold for applications requiring higher precision.

BLOCK DIAGRAM

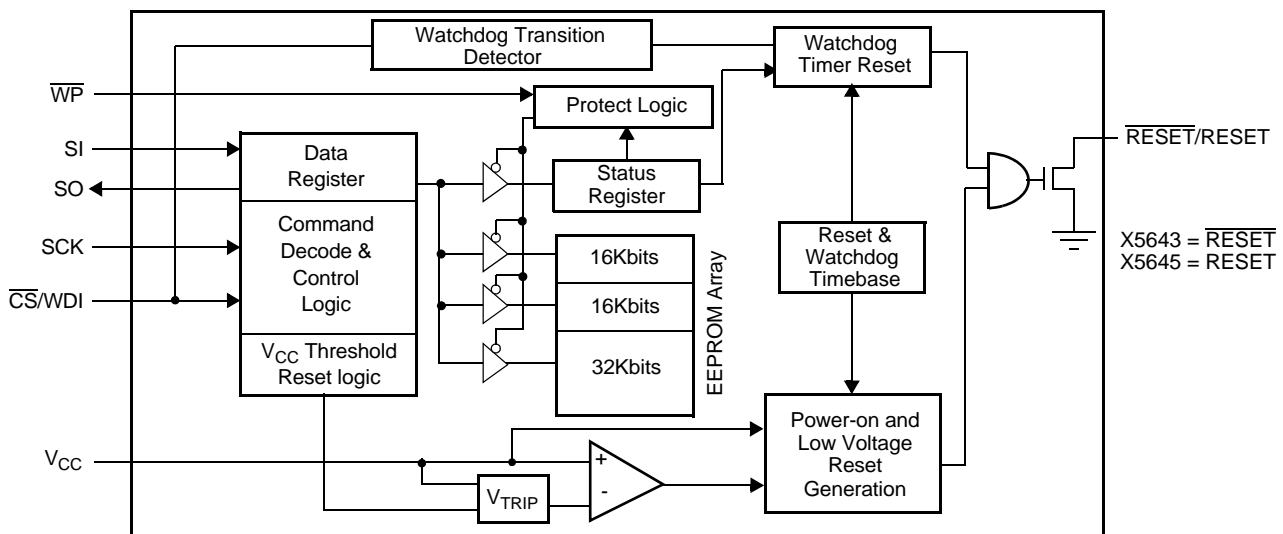

X5643, X5645

PIN CONFIGURATION



Pin PDIP	Pin SOIC	Pin TSSOP	Name	Function
1	2 & 3	2	$\overline{\text{CS}}/\text{WDI}$	Chip Select Input. $\overline{\text{CS}}$ HIGH, deselects the device and the SO output pin is at a high impedance state. Unless a nonvolatile write cycle is underway, the device will be in the standby power mode. $\overline{\text{CS}}$ LOW enables the device, placing it in the active power mode. Prior to the start of any operation after power-up, a HIGH to LOW transition on $\overline{\text{CS}}$ is required. Watchdog Input. A HIGH to LOW transition on the WDI pin restarts the watchdog timer. The absence of a HIGH to LOW transition within the watchdog time out period results in $\overline{\text{RESET}}/\text{RESET}$ going active.
2	4	3	SO	Serial Output. SO is a push/pull serial data output pin. A read cycle shifts data out on this pin. The falling edge of the serial clock (SCK) clocks the data out.
5	9	13	SI	Serial Input. SI is a serial data input pin. Input all opcodes, byte addresses, and memory data on this pin. The rising edge of the serial clock (SCK) latches the input data. Send all opcodes (Table 1), addresses and data MSB first.
6	10	14	SCK	Serial Clock. The serial clock controls the serial bus timing for data input and output. The rising edge of SCK latches in the opcode, address, or data bits present on the SI pin. The falling edge of SCK changes the data output on the SO pin.
3	5	7	$\overline{\text{WP}}$	Write Protect. The $\overline{\text{WP}}$ pin works in conjunction with a nonvolatile WPEN bit to "lock" the setting of the watchdog timer control and the memory write protect bits.
4	6	8	V_{SS}	Ground
8	12 & 13	19	V_{CC}	Supply Voltage
7	11	18	$\overline{\text{RESET}}/\text{RESET}$	Reset Output. $\overline{\text{RESET}}/\text{RESET}$ is an active LOW/HIGH, open drain output which goes active whenever V_{CC} falls below the minimum V_{CC} sense level. It will remain active until V_{CC} rises above the minimum V_{CC} sense level for 200ms. $\overline{\text{RESET}}/\text{RESET}$ goes active if the watchdog timer is enabled and $\overline{\text{CS}}$ remains either HIGH or LOW longer than the selectable watchdog time out period. A falling edge of $\overline{\text{CS}}$ will reset the watchdog timer. $\overline{\text{RESET}}/\text{RESET}$ goes active on power-up at about 1V and remains active for 200ms after the power supply stabilizes.
	1, 7, 8, 14	1, 4-6, 9-12, 15-17, 20	NC	No internal connections

X5643, X5645

PRINCIPLES OF OPERATION

Power-on Reset

Application of power to the X5643/X5645 activates a power-on reset circuit. This circuit goes active at about 1V and pulls the $\overline{\text{RESET}}/\text{RESET}$ pin active. This signal prevents the system microprocessor from starting to operate with insufficient voltage or prior to stabilization of the oscillator. When V_{CC} exceeds the device V_{TRIP} value for 200ms (nominal) the circuit releases $\overline{\text{RESET}}/\text{RESET}$, allowing the processor to begin executing code.

Low Voltage Monitoring

During operation, the X5643/X5645 monitors the V_{CC} level and asserts $\overline{\text{RESET}}/\text{RESET}$ if supply voltage falls below a preset minimum V_{TRIP} . The $\overline{\text{RESET}}/\text{RESET}$ signal prevents the microprocessor from operating in a power fail or brownout condition. The $\overline{\text{RESET}}/\text{RESET}$ signal remains active until the voltage drops below 1V. It also remains active until V_{CC} returns and exceeds V_{TRIP} for 200ms.

Watchdog Timer

The watchdog timer circuit monitors the microprocessor activity by monitoring the WDI input. The microprocessor must toggle the $\overline{\text{CS}}/\text{WDI}$ pin periodically to prevent a $\overline{\text{RESET}}/\text{RESET}$ signal. The $\overline{\text{CS}}/\text{WDI}$ pin must be toggled from HIGH to LOW prior to the expiration of the watchdog time out period. The state of two nonvolatile control bits in the status register determine the watchdog timer period. The microprocessor can change these watchdog bits, or they may be "locked" by tying the $\overline{\text{WP}}$ pin LOW and setting the WPEN bit HIGH.

V_{CC} Threshold Reset Procedure

The X5643/X5645 has a standard V_{CC} threshold (V_{TRIP}) voltage. This value will not change over normal operating and storage conditions. However, in applications where the standard V_{TRIP} is not exactly right, or for higher precision in the V_{TRIP} value, the X5643/X5645 threshold may be adjusted.

Setting the V_{TRIP} Voltage

This procedure sets the V_{TRIP} to a higher voltage value. For example, if the current V_{TRIP} is 4.4V and the new V_{TRIP} is 4.6V, this procedure directly makes the change. If the new setting is lower than the current setting, then it is necessary to reset the trip point before setting the new value.

To set the new V_{TRIP} voltage, apply the desired V_{TRIP} threshold to the V_{CC} pin and tie the $\overline{\text{CS}}/\text{WDI}$ pin and the $\overline{\text{WP}}$ pin HIGH. $\overline{\text{RESET}}/\text{RESET}$ and SO pins are left unconnected. Then apply the programming voltage V_P to both SCK and SI and pulse $\overline{\text{CS}}/\text{WDI}$ LOW then HIGH. Remove V_P and the sequence is complete.

Figure 1. Set V_{TRIP} Voltage

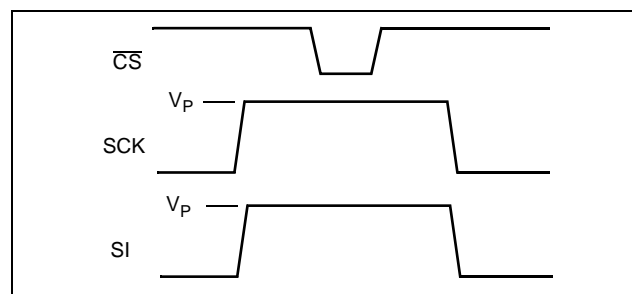

Resetting the V_{TRIP} Voltage

This procedure sets the V_{TRIP} to a "native" voltage level. For example, if the current V_{TRIP} is 4.4V and the V_{TRIP} is reset, the new V_{TRIP} is something less than 1.7V. This procedure must be used to set the voltage to a lower value.

To reset the V_{TRIP} voltage, apply a voltage between 2.7 and 5.5V to the V_{CC} pin. Tie the $\overline{\text{CS}}/\text{WDI}$ pin, the $\overline{\text{WP}}$ pin, and the SCK pin HIGH. $\overline{\text{RESET}}/\text{RESET}$ and SO pins are left unconnected. Then apply the programming voltage V_P to the SI pin ONLY and pulse $\overline{\text{CS}}/\text{WDI}$ LOW then HIGH. Remove V_P and the sequence is complete.

Figure 2. Reset V_{TRIP} Voltage

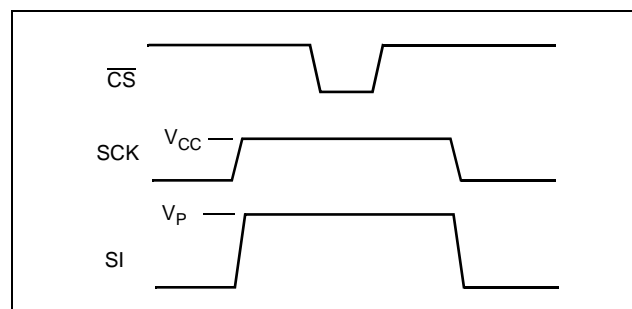

X5643, X5645

Figure 3. V_{TRIP} Programming Sequence Flow Chart

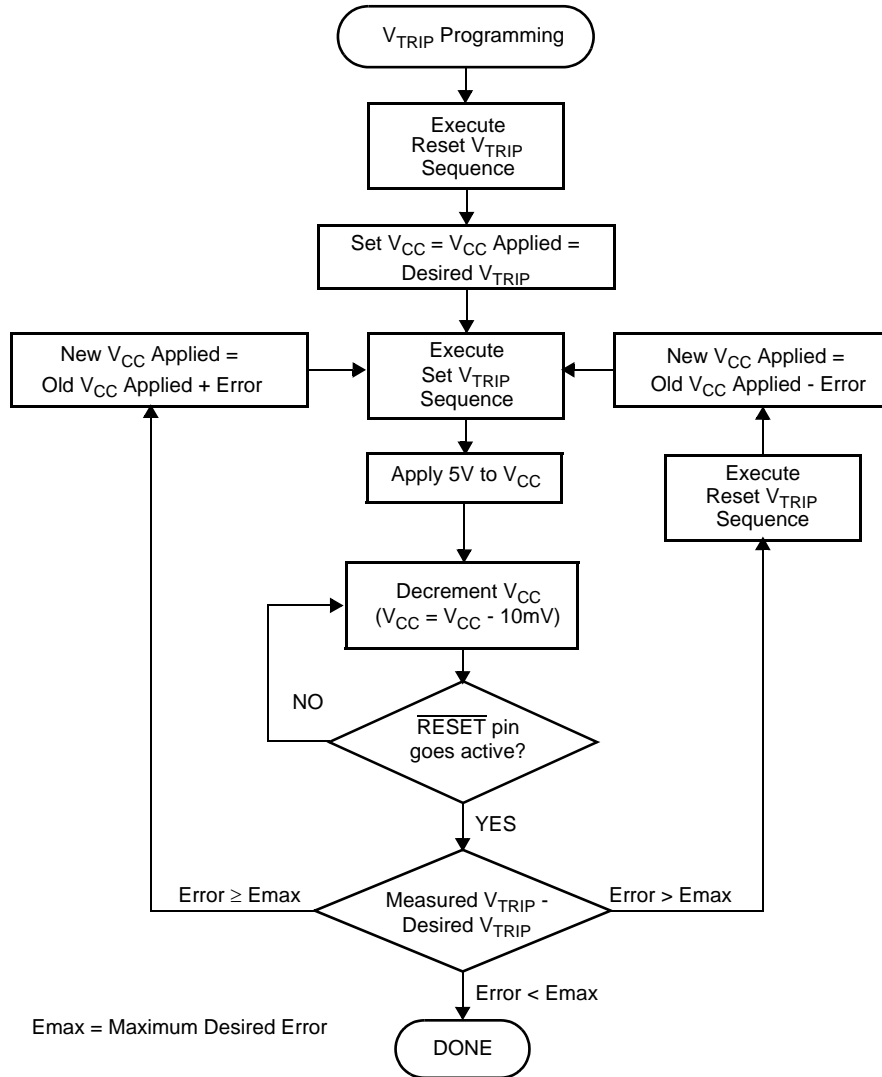

X5643, X5645

Figure 4. Sample V_{TRIP} Reset Circuit

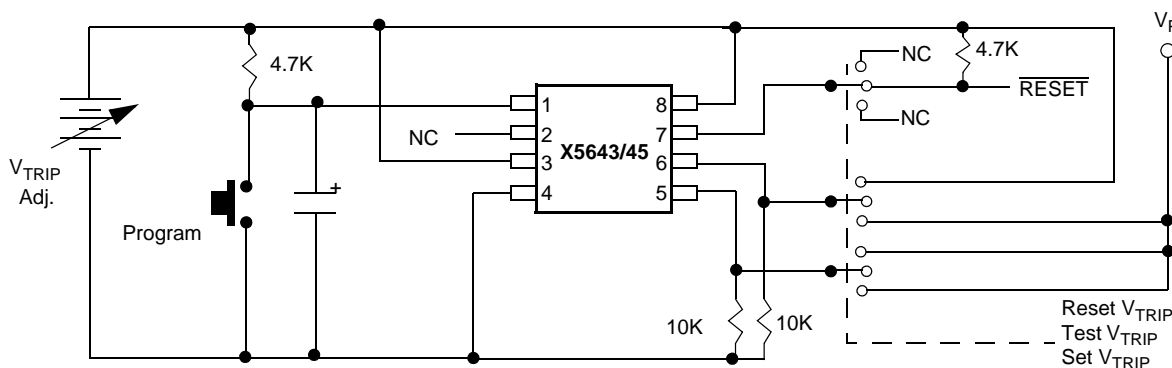

SPI SERIAL MEMORY

The memory portion of the device is a CMOS serial EEPROM array with Intersil's block lock protection. The array is internally organized as x 8. The device features a Serial Peripheral Interface (SPI) and software protocol allowing operation on a simple four-wire bus.

The device utilizes Intersil's proprietary Direct Write™ cell, providing a minimum endurance of 100,000 cycles and a minimum data retention of 100 years.

The device is designed to interface directly with the synchronous Serial Peripheral Interface (SPI) of many popular microcontroller families. It contains an 8-bit instruction register that is accessed via the SI input, with data being clocked in on the rising edge of SCK. CS must be LOW during the entire operation.

All instructions (Table 1), addresses and data are transferred MSB first. Data input on the SI line is latched on the first rising edge of SCK after CS goes LOW. Data is output on the SO line by the falling edge of SCK. SCK is static, allowing the user to stop the clock and then start it again to resume operations where left off.

Table 1. Instruction Set

Instruction Name	Instruction Format*	Operation
WREN	0000 0110	Set the write enable latch (enable write operations)
SFLB	0000 0000	Set flag bit
WRDI/RFLB	0000 0100	Reset the write enable latch/reset flag bit
RSDR	0000 0101	Read status register
WRSR	0000 0001	Write status register (watchdog, block lock, WPEN & flag bits)
READ	0000 0011	Read data from memory array beginning at selected address
WRITE	0000 0010	Write data to memory array beginning at selected address

Note: *Instructions are shown MSB in leftmost position. Instructions are transferred MSB first.

Write Enable Latch

The device contains a write enable latch. This latch must be SET before a write operation is initiated. The WREN instruction will set the latch and the WRDI instruction will reset the latch (Figure 3). This latch is automatically reset upon a power-up condition and after the completion of a valid Write Cycle.

Status Register

The RDSR instruction provides access to the status register. The status register may be read at any time, even during a write cycle. The status register is formatted as follows:

7	6	5	4	3	2	1	0
WPEN	FLB	WD1	WD0	BL1	BL0	WEL	WIP

The Write-In-Progress (WIP) bit is a volatile, read only bit and indicates whether the device is busy with an internal nonvolatile write operation. The WIP bit is read using the RDSR instruction. When set to a "1", a non-volatile write operation is in progress. When set to a "0", no write is in progress.

X5643, X5645

Table 2. Block Protect Matrix

WREN CMD	Status Register	Device Pin	Block	Block	Status Register
WEL	WPEN	WP#	Protected Block	Unprotected Block	WPEN, BL0, BL1 WD0, WD1
0	X	X	Protected	Protected	Protected
1	1	0	Protected	Writable	Protected
1	0	X	Protected	Writable	Writable
1	X	1	Protected	Writable	Writable

The Write Enable Latch (WEL) bit indicates the status of the write enable latch. When WEL = 1, the latch is set HIGH and when WEL = 0 the latch is reset LOW. The WEL bit is a volatile, read only bit. It can be set by the WREN instruction and can be reset by the WRDS instruction.

The block lock bits, BL0 and BL1, set the level of block lock protection. These nonvolatile bits are programmed using the WRSR instruction and allow the user to protect one quarter, one half, all or none of the EEPROM array. Any portion of the array that is block lock protected can be read but not written. It will remain protected until the BL bits are altered to disable block lock protection of that portion of memory.

Status Register Bits		Array Addresses Protected
BL1	BL0	X5643/X5645
0	0	None
0	1	\$1800-\$1FFF
1	0	\$1000-\$1FFF
1	1	\$0000-\$1FFF

The watchdog timer bits, WD0 and WD1, select the watchdog time out period. These nonvolatile bits are programmed with the WRSR instruction.

Status Register Bits		Watchdog Time Out (Typical)
WD1	WD0	
0	0	1.4 seconds
0	1	600 milliseconds
1	0	200 milliseconds
1	1	disabled

The FLAG bit shows the status of a volatile latch that can be set and reset by the system using the SFLB and RFLB instructions. The flag bit is automatically reset upon power-up. This flag can be used by the system to determine whether a reset occurs as a result of a watchdog time out or power failure.

The nonvolatile WPEN bit is programmed using the WRSR instruction. This bit works in conjunction with the \overline{WP} pin to provide an in-circuit programmable ROM function (Table 2). \overline{WP} is LOW and WPEN bit programmed HIGH disables all status register write operations.

In Circuit Programmable ROM Mode

This mechanism protects the block lock and watchdog bits from inadvertent corruption.

In the locked state (programmable ROM mode) the \overline{WP} pin is LOW and the nonvolatile bit WPEN is "1". This mode disables nonvolatile writes to the device's status register.

X5643, X5645

Figure 5. Read EEPROM Array Sequence

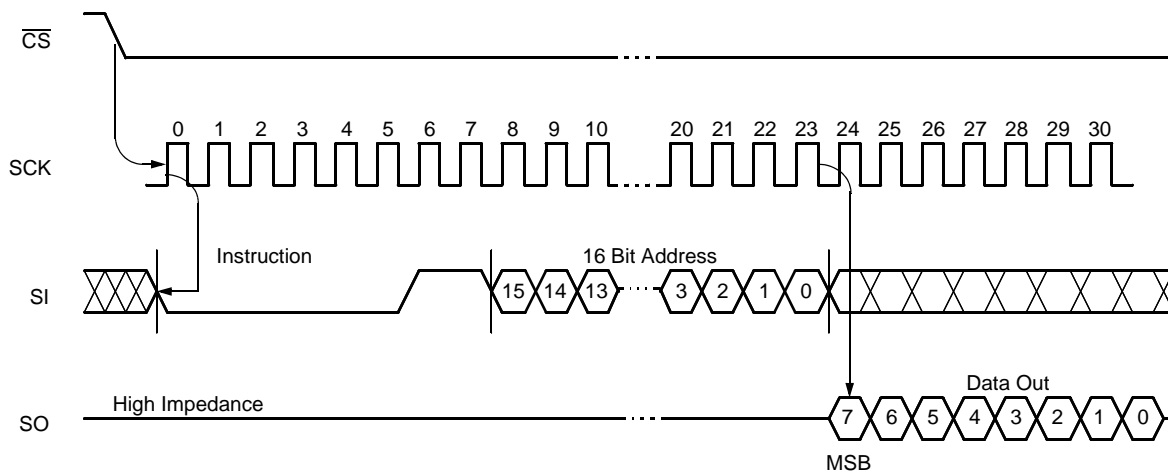

Setting the \overline{WP} pin LOW while WPEN is a “1” while an internal write cycle to the status register is in progress will not stop this write operation, but the operation disables subsequent write attempts to the status register.

When \overline{WP} is HIGH, all functions, including nonvolatile writes to the status register operate normally. Setting the WPEN bit in the status register to “0” blocks the \overline{WP} pin function, allowing writes to the status register when \overline{WP} is HIGH or LOW. Setting the WPEN bit to “1” while the \overline{WP} pin is LOW activates the programmable ROM mode, thus requiring a change in the \overline{WP} pin prior to subsequent status register changes. This allows manufacturing to install the device in a system with \overline{WP} pin grounded and still be able to program the status register. Manufacturing can then load configuration data, manufacturing time and other parameters into the EEPROM, then set the portion of memory to be protected by setting the block lock bits, and finally set the “OTP mode” by setting the WPEN bit. Data changes now require a hardware change.

Read Sequence

When reading from the EEPROM memory array, \overline{CS} is first pulled low to select the device. The 8-bit READ instruction is transmitted to the device, followed by the 16-bit address. After the READ opcode and address are sent, the data stored in the memory at the selected address is shifted out on the SO line. The data stored in memory at the next address can be read sequentially by continuing to provide clock pulses. The address is automatically incremented to the next higher address after each byte of data is shifted out. When the highest address is reached, the address counter rolls over to address \$0000 allowing the read cycle to be continued indefinitely. The read operation is terminated by taking \overline{CS} high. Refer to the read EEPROM array sequence (Figure 1).

To read the status register, the \overline{CS} line is first pulled low to select the device followed by the 8-bit RDSR instruction. After the RDSR opcode is sent, the contents of the status register are shifted out on the SO line. Refer to the read status register sequence (Figure 2).

Write Sequence

Prior to any attempt to write data into the device, the “Write Enable” Latch (WEL) must first be set by issuing the WREN instruction (Figure 3). \overline{CS} is first taken LOW, then the WREN instruction is clocked into the device. After all eight bits of the instruction are transmitted, \overline{CS} must then be taken HIGH. If the user continues the write operation without taking \overline{CS} HIGH after issuing the WREN instruction, the write operation will be ignored.

To write data to the EEPROM memory array, the user then issues the WRITE instruction followed by the 16 bit address and then the data to be written. Any unused address bits are specified to be “0’s”. The WRITE operation minimally takes 32 clocks. \overline{CS} must go low and remain low for the duration of the operation. If the address counter reaches the end of a page and the clock continues, the counter will roll back to the first address of the page and overwrite any data that may have been previously written.

For the page write operation (byte or page write) to be completed, \overline{CS} can only be brought HIGH after bit 0 of the last data byte to be written is clocked in. If it is brought HIGH at any other time, the write operation will not be completed (Figure 4).

To write to the status register, the WRSR instruction is followed by the data to be written (Figure 5). Data bits 0 and 1 must be “0”.

X5643, X5645

While the write is in progress following a status register or EEPROM sequence, the status register may be read to check the WIP bit. During this time the WIP bit will be high.

OPERATIONAL NOTES

The device powers-up in the following state:

- The device is in the low power standby state.
- A HIGH to LOW transition on \overline{CS} is required to enter an active state and receive an instruction.
- SO pin is high impedance.

- The write enable latch is reset.
- The flag bit is reset.
- Reset signal is active for t_{PURST} .

Data Protection

The following circuitry has been included to prevent inadvertent writes:

- A WREN instruction must be issued to set the write enable latch.
- \overline{CS} must come HIGH at the proper clock count in order to start a nonvolatile write cycle.

Figure 6. Read Status Register Sequence

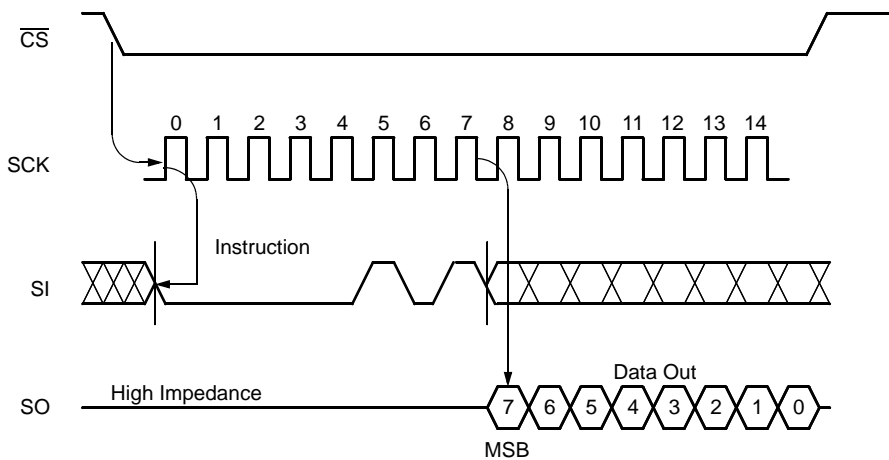
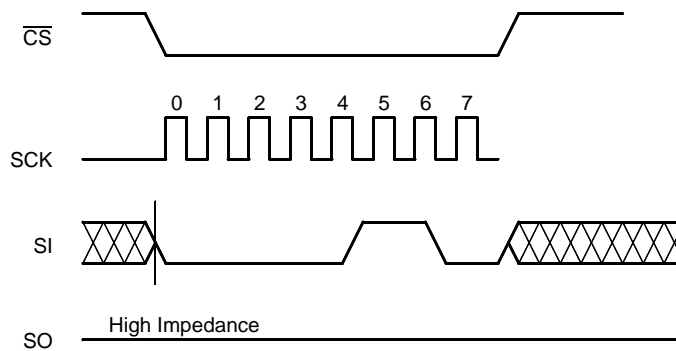

Figure 7. Write Enable Latch Sequence



X5643, X5645

Figure 8. Write Sequence

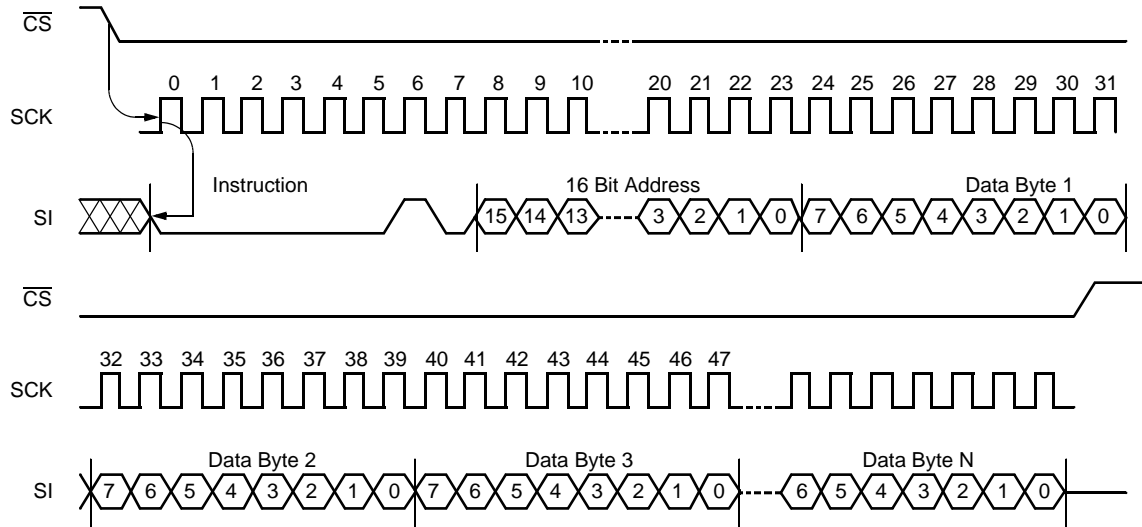
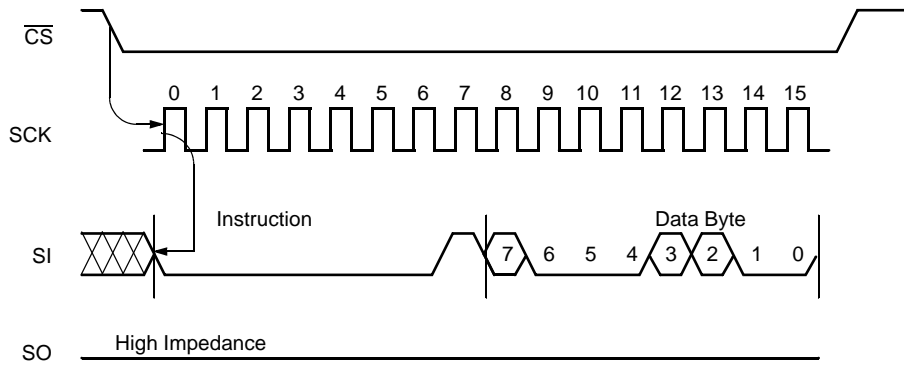

Figure 9. Status Register Write Sequence



SYMBOL TABLE

WAVEFORM	INPUTS	OUTPUTS
	Must be steady	Will be steady
	May change from LOW to HIGH	Will change from LOW to HIGH
	May change from HIGH to LOW	Will change from HIGH to LOW
	Don't Care: Changes Allowed	Changing: State Not Known
	N/A	Center Line is High Impedance

X5643, X5645

ABSOLUTE MAXIMUM RATINGS

Temperature under bias -65°C to +135°C
 Storage temperature -65°C to +150°C
 Voltage on any pin with respect to V_{SS} -1.0V to +7V
 D.C. output current 5mA
 Lead temperature (soldering, 10 seconds)..... 300°C

COMMENT

Stresses above those listed under “Absolute Maximum Ratings” may cause permanent damage to the device. This is a stress rating only; the functional operation of the device (at these or any other conditions above those listed in the operational sections of this specification) is not implied. Exposure to absolute maximum rating conditions for extended periods may affect device reliability.

RECOMMENDED OPERATING CONDITIONS

Temperature	Min.	Max.
Commercial	0°C	70°C
Industrial	-40°C	+85°C

Device Option	Supply Voltage
-2.7 or -2.7A	2.7V to 5.5V
Blank or -4.5A	4.5V-5.5V

D.C. OPERATING CHARACTERISTICS (Over the recommended operating conditions unless otherwise specified.)

Symbol	Parameter	Limits			Unit	Test Conditions
		Min.	Typ.	Max.		
I_{CC1}	V_{CC} write current (active)			5	mA	SCK = $V_{CC} \times 0.1/V_{CC} \times 0.9$ @ 2MHz, SO = Open
I_{CC2}	V_{CC} read current (active)			0.4	mA	SCK = $V_{CC} \times 0.1/V_{CC} \times 0.9$ @ 2MHz, SO = Open
I_{SB1}	V_{CC} standby current WDT=OFF			1	μ A	$\overline{CS} = V_{CC}$, $V_{IN} = V_{SS}$ or V_{CC} , $V_{CC} = 5.5V$
I_{SB2}	V_{CC} standby current WDT=ON			50	μ A	$\overline{CS} = V_{CC}$, $V_{IN} = V_{SS}$ or V_{CC} , $V_{CC} = 5.5V$
I_{SB3}	V_{CC} standby current WDT=ON			20	μ A	$\overline{CS} = V_{CC}$, $V_{IN} = V_{SS}$ or V_{CC} , $V_{CC} = 3.6V$
I_{LI}	Input leakage current		0.1	10	μ A	$V_{IN} = V_{SS}$ to V_{CC}
I_{LO}	Output leakage current		0.1	10	μ A	$V_{OUT} = V_{SS}$ to V_{CC}
$V_{IL}^{(1)}$	Input LOW voltage	-0.5		$V_{CC} \times 0.3$	V	
$V_{IH}^{(1)}$	Input HIGH voltage	$V_{CC} \times 0.7$		$V_{CC} + 0.5$	V	
V_{OL1}	Output LOW voltage			0.4	V	$V_{CC} > 3.3V$, $I_{OL} = 2.1mA$
V_{OL2}	Output LOW voltage			0.4	V	$2V < V_{CC} \leq 3.3V$, $I_{OL} = 1mA$
V_{OL3}	Output LOW voltage			0.4	V	$V_{CC} \leq 2V$, $I_{OL} = 0.5mA$
V_{OH1}	Output HIGH voltage	$V_{CC} - 0.8$			V	$V_{CC} > 3.3V$, $I_{OH} = -1.0mA$
V_{OH2}	Output HIGH voltage	$V_{CC} - 0.4$			V	$2V < V_{CC} \leq 3.3V$, $I_{OH} = -0.4mA$
V_{OH3}	Output HIGH voltage	$V_{CC} - 0.2$			V	$V_{CC} \leq 2V$, $I_{OH} = -0.25mA$
V_{OLS}	Reset output LOW voltage			0.4	V	$I_{OL} = 1mA$

X5643, X5645

CAPACITANCE $T_A = +25^\circ\text{C}$, $f = 1\text{MHz}$, $V_{CC} = 5\text{V}$

Symbol	Test	Max.	Unit	Conditions
$C_{OUT}^{(2)}$	Output Capacitance (SO, $\overline{\text{RESET}}/\text{RESET}$)	8	pF	$V_{OUT} = 0\text{V}$
$C_{IN}^{(2)}$	Input Capacitance (SCK, SI, $\overline{\text{CS}}$, $\overline{\text{WP}}$)	6	pF	$V_{IN} = 0\text{V}$

Notes: (1) V_{IL} min. and V_{IH} max. are for reference only and are not tested.
 (2) This parameter is periodically sampled and not 100% tested.

EQUIVALENT A.C. LOAD CIRCUIT AT 5V V_{CC}

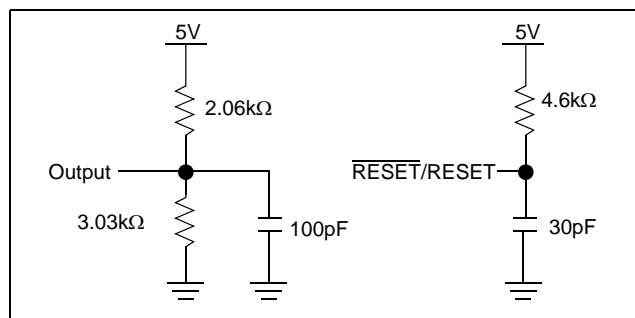

A.C. TEST CONDITIONS

Input pulse levels	$V_{CC} \times 0.1$ to $V_{CC} \times 0.9$
Input rise and fall times	10ns
Input and output timing level	$V_{CC} \times 0.5$

A.C. CHARACTERISTICS (Over recommended operating conditions, unless otherwise specified)

Serial Input Timing

Symbol	Parameter	2.7-5.5V		Unit
		Min.	Max.	
f_{SCK}	Clock frequency	0	2	MHz
t_{CYC}	Cycle time	500		ns
t_{LEAD}	$\overline{\text{CS}}$ lead time	250		ns
t_{LAG}	$\overline{\text{CS}}$ lag time	250		ns
t_{WH}	Clock HIGH time	200		ns
t_{WL}	Clock LOW time	250		ns
t_{SU}	Data setup time	50		ns
t_H	Data hold time	50		ns
$t_{RI}^{(3)}$	Input rise time		100	ns
$t_{FI}^{(3)}$	Input fall time		100	ns
t_{CS}	$\overline{\text{CS}}$ deselect time	500		ns
$t_{WC}^{(4)}$	Write cycle time		10	ms

X5643, X5645

Serial Input Timing

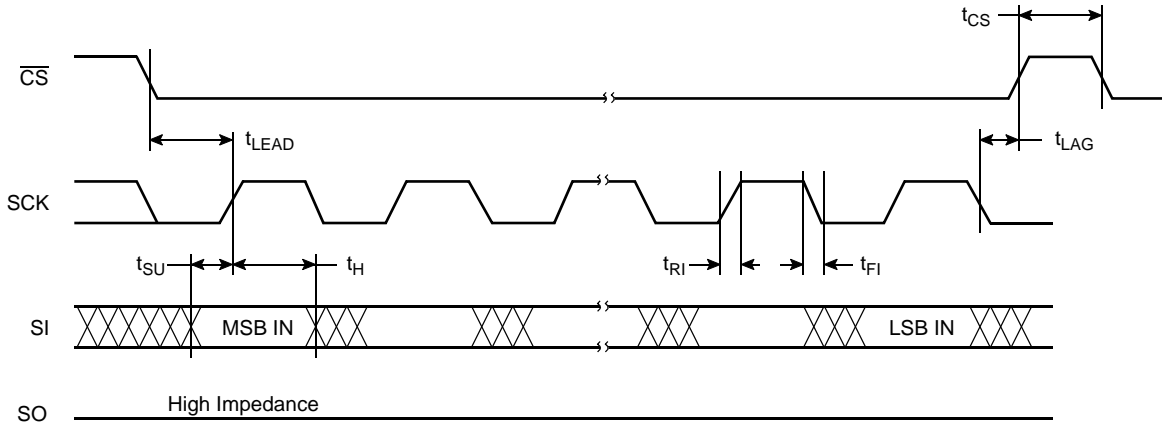

Serial Output Timing

Symbol	Parameter	2.7-5.5V		Unit
		Min.	Max.	
f_{SCK}	Clock frequency	0	2	MHz
t_{DIS}	Output disable time		250	ns
t_V	Output valid from clock low		250	ns
t_{HO}	Output hold time	0		ns
$t_{RO}^{(3)}$	Output rise time		100	ns
$t_{FO}^{(3)}$	Output fall time		100	ns

Notes: (3) This parameter is periodically sampled and not 100% tested.
 (4) t_{WC} is the time from the rising edge of \overline{CS} after a valid write sequence has been sent to the end of the self-timed internal nonvolatile write cycle.

Serial Output Timing

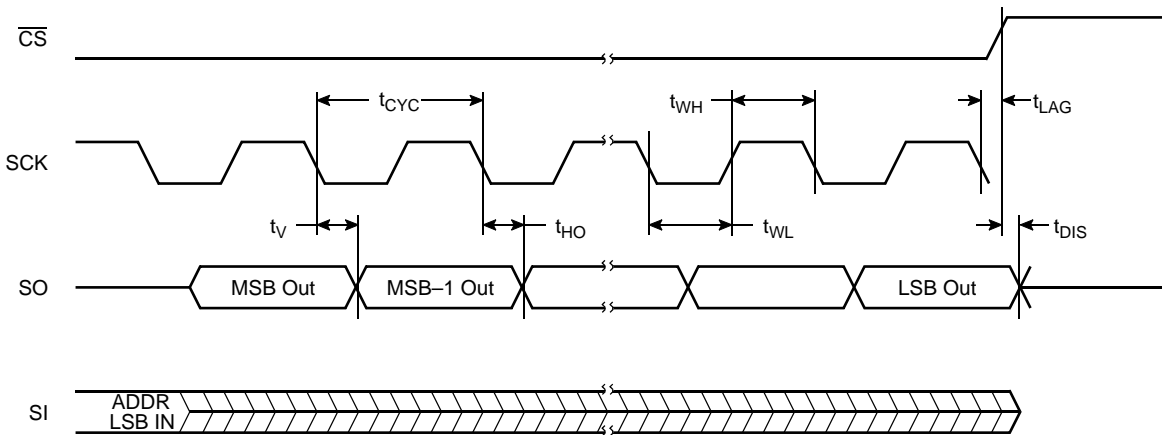

X5643, X5645

Power-Up and Power-Down Timing

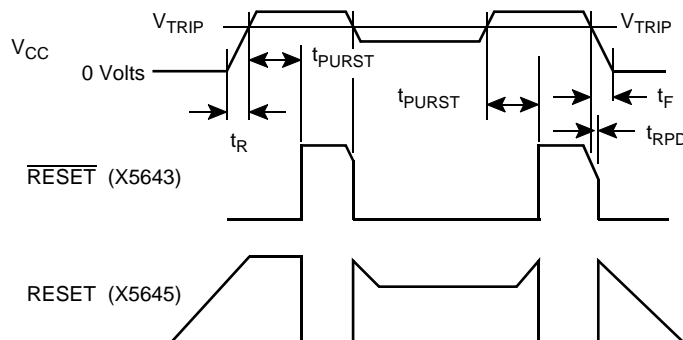

RESET Output Timing

Symbol	Parameter	Min.	Typ.	Max.	Unit
V_{TRIP}	Reset trip point voltage, X5643-4.5A, X5643-4.5A	4.5	4.63	4.75	V
	Reset trip point voltage, X5643, X5645	4.25	4.38	4.5	
	Reset trip point voltage, X5643-2.7A, X5645-2.7A	2.85	2.93	3.0	
	Reset trip point voltage, X5643-2.7, X5645-2.7	2.55	2.63	2.7	
V_{TH}	V_{TRIP} hysteresis (HIGH to LOW vs. LOW to HIGH V_{TRIP} voltage)		20		mV
t_{PURST}	Power-up reset time out	100	200	280	ms
$t_{RPD}^{(5)}$	V_{CC} detect to reset/output			500	ns
$t_F^{(5)}$	V_{CC} fall time	100			μ s
$t_R^{(5)}$	V_{CC} rise time	100			μ s
V_{RVALID}	Reset valid V_{CC}	1			V

Note: (5) This parameter is periodically sampled and not 100% tested.

CS/WDI vs. RESET/RESET Timing

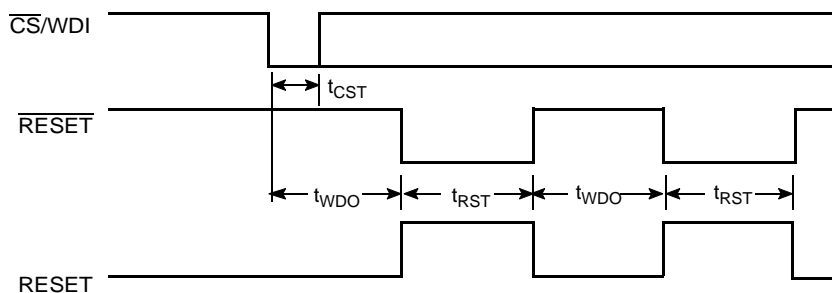

X5643, X5645

RESET/RESET Output Timing

Symbol	Parameter	Min.	Typ.	Max.	Unit
t_{WDO}	Watchdog time out period, WD1 = 1, WD0 = 0	100	200	300	ms
	WD1 = 0, WD0 = 1	450	600	800	ms
	WD1 = 0, WD0 = 0	1	1.4	2	sec
t_{CST}	\overline{CS} pulse width to reset the watchdog	400			ns
t_{RST}	Reset time out	100	200	300	ms

V_{TRIP} Set Conditions

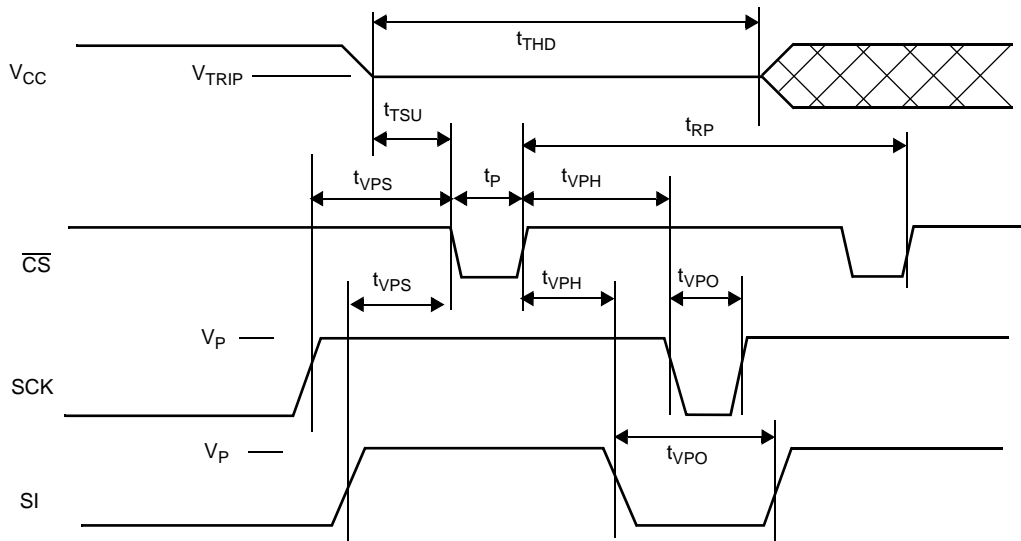

V_{TRIP} Reset Conditions

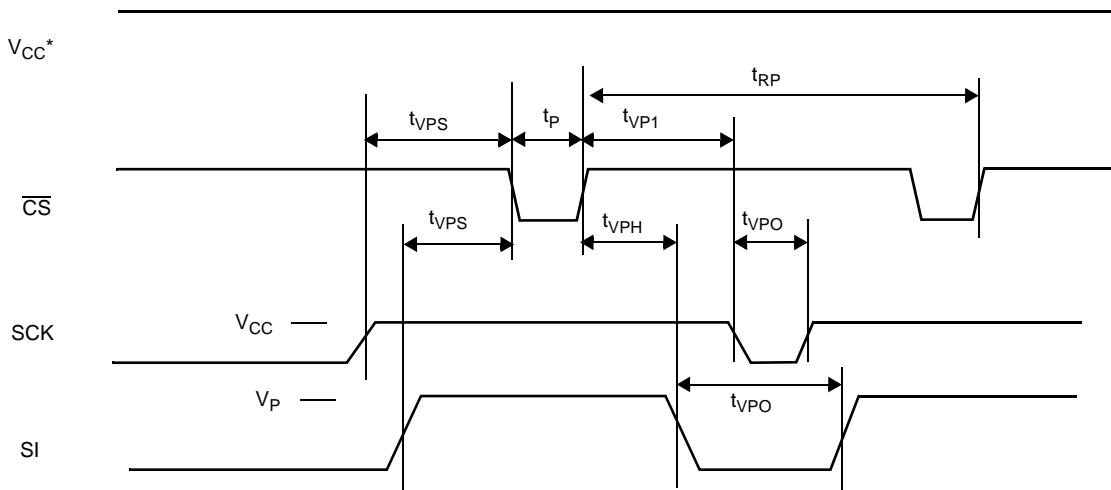

*V_{CC} > Programmed V_{TRIP}

X5643, X5645

V_{TRIP} Programming Specifications V_{CC} = 1.7-5.5V; Temperature = 0°C to 70°C

Parameter	Description	Min.	Max.	Unit
t _{VPS}	SCK V _{TRIP} program voltage setup time	1		μs
t _{VPH}	SCK V _{TRIP} program voltage hold time	1		μs
t _P	V _{TRIP} program pulse width	1		μs
t _{TSU}	V _{TRIP} level setup time	10		μs
t _{THD}	V _{TRIP} level hold (stable) time	10		ms
t _{WC}	V _{TRIP} write cycle time		10	ms
t _{RP}	V _{TRIP} program cycle recovery period (between successive programming cycles)	10		ms
t _{VPO}	SCK V _{TRIP} program voltage off time before next cycle	0		ms
V _P	Programming voltage	15	18	V
V _{TRAN}	V _{TRIP} programmed voltage range	1.7	5.0	V
V _{ta1}	Initial V _{TRIP} program voltage accuracy (V _{CC} applied-V _{TRIP}) (programmed at 25°C)	-0.1	+0.4	V
V _{ta2}	Subsequent V _{TRIP} Program Voltage accuracy [(V _{CC} applied-V _{ta1})-V _{TRIP}] (programmed at 25°C)	-25	+25	mV
V _{tr}	V _{TRIP} Program Voltage repeatability (successive program operations) (programmed at 25°C)	-25	+25	mV
V _{tv}	V _{TRIP} program variation after programming (0-75°C). (programmed at 25°C)	-25	+25	mV

V_{TRIP} programming parameters are periodically sampled and are not 100% tested.

X5643, X5645

TYPICAL PERFORMANCE

V_{CC} Supply Current vs. Temperature (I_{SB})

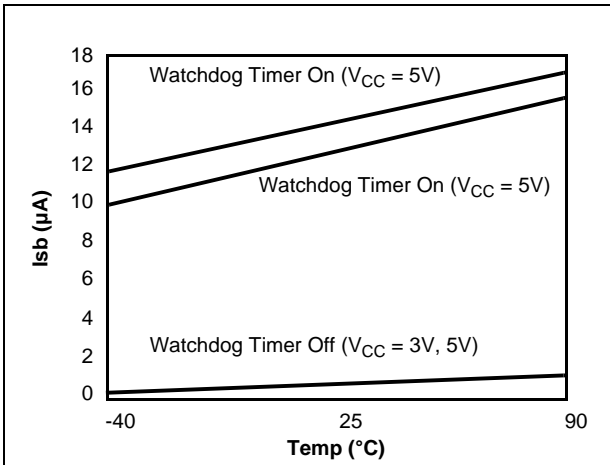

t_{WDO} vs. Voltage/Temperature (WD1, 0 = 1, 1)

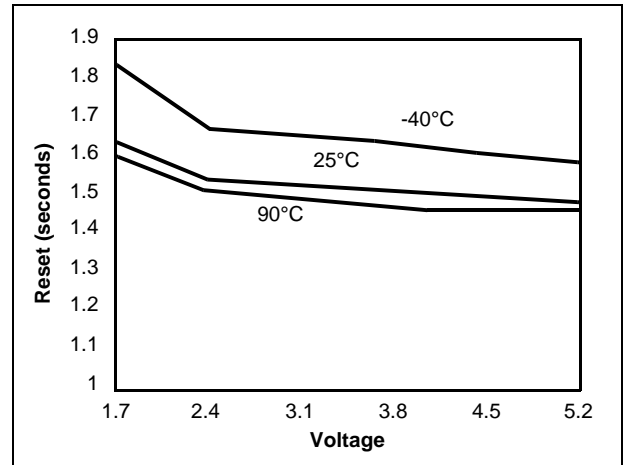

V_{TRIP} vs. Temperature (programmed at 25°C)

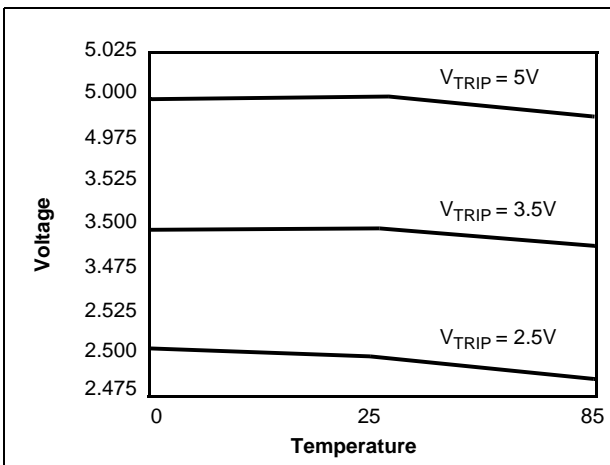

t_{WDO} vs. Voltage/Temperature (WD1, 0 = 1, 0)

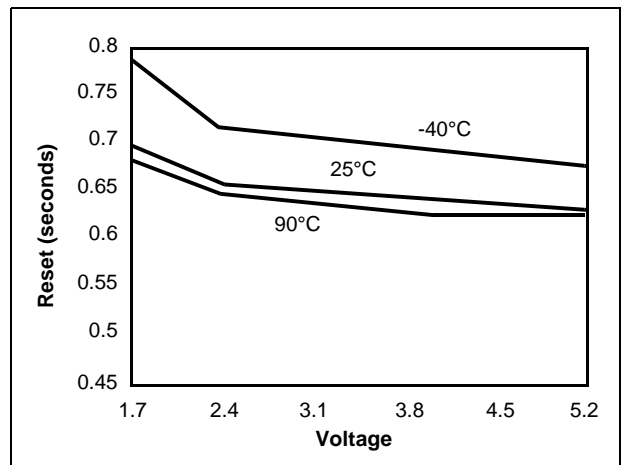

t_{PURST} vs. Temperature

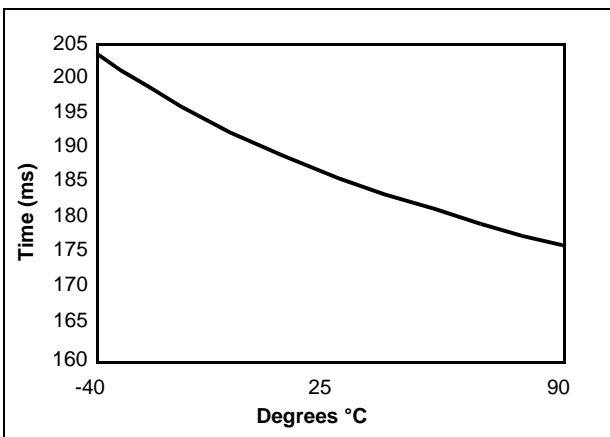

t_{WDO} vs. Voltage/Temperature (WD1, 0 0 = 0, 1)

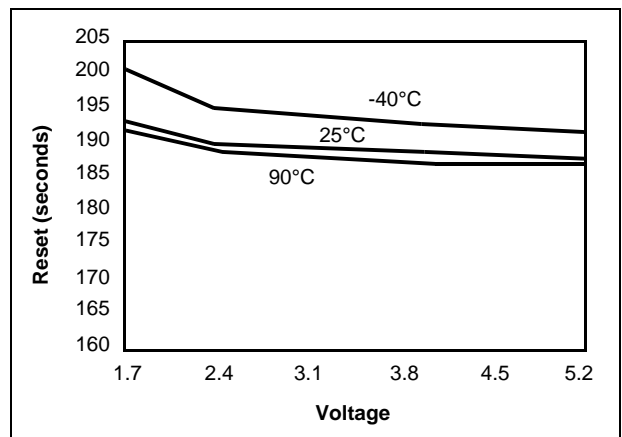

X5643, X5645

PACKAGING INFORMATION

8-Lead Plastic Dual In-Line Package Type P

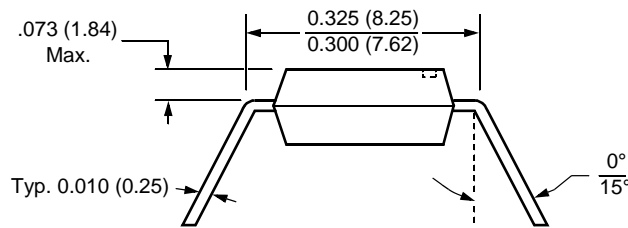
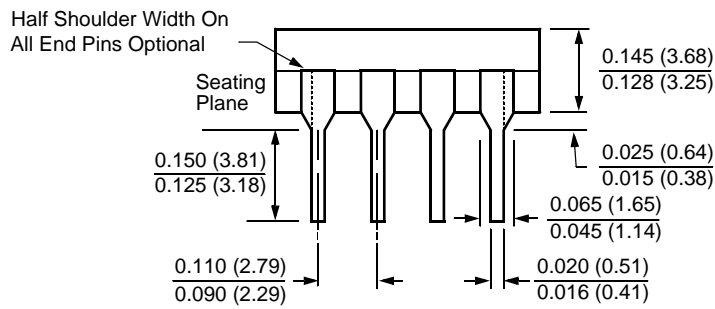
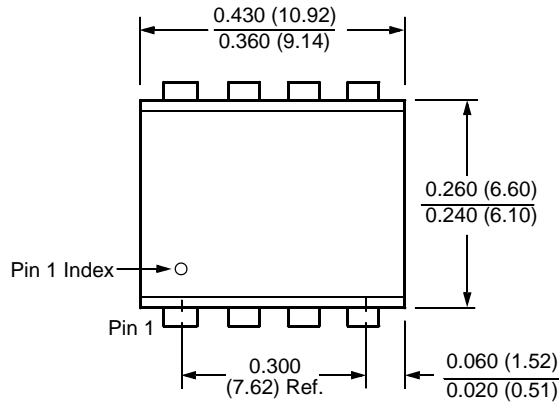

- NOTE:**
1. ALL DIMENSIONS IN INCHES (IN PARENTHESES IN MILLIMETERS)
 2. PACKAGE DIMENSIONS EXCLUDE MOLDING FLASH

X5643, X5645

PACKAGING INFORMATION

14-Lead Plastic Small Outline Gullwing Package Type S

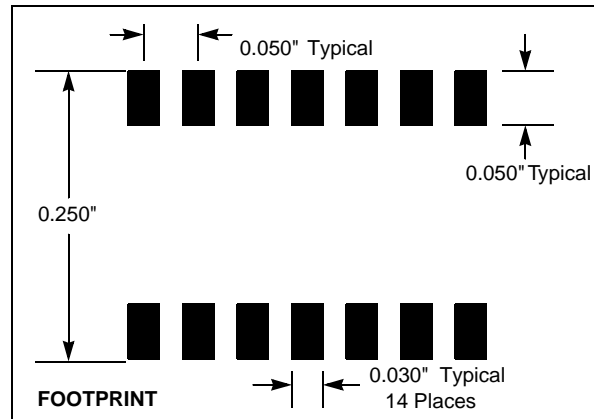
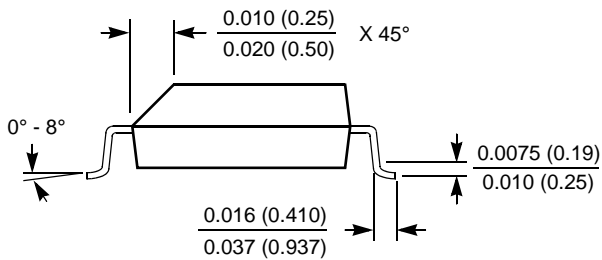
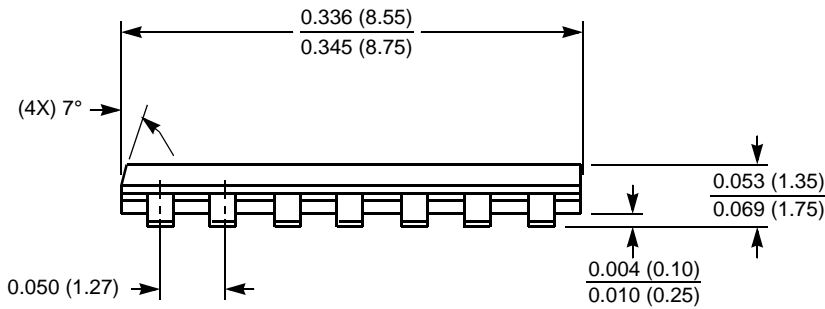
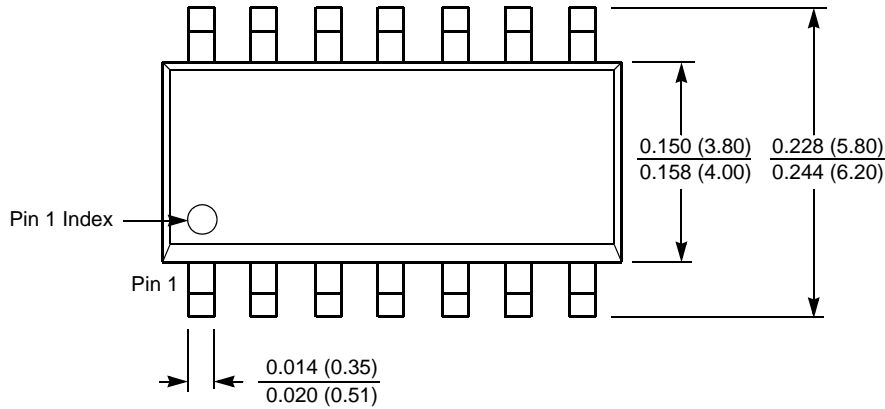

NOTE: ALL DIMENSIONS IN INCHES (IN PARENTHESES IN MILLIMETERS)

X5643, X5645

Ordering Information

V _{CC} Range	V _{TRIP} Range	Package	Operating Temperature Range	Part Number RESET (Active LOW)	Part Number RESET (Active HIGH)
4.5-5.5V	4.5.4.75	8 pin PDIP	0-70°C	X5643P-4.5A	X5645P-4.5A
		14L SOIC	0-70°C	X5643S14-4.5A	X5645S14-4.5A
			-40-85°C	X5643S14I-4.5A	X5645S14I-4.5A
4.5-5.5V	4.25.4.5	8 pin PDIP	0-70°C	X5643P	X5645P
		14L SOIC	0-70°C	X5643S14	X5645S14
			-40-85°C	X5643S14I	X5645S14I
2.7-5.5V	2.85-3.0	14L SOIC	0-70°C	X5643S14-2.7A	X5645S14-2.7A
2.7-5.5V	2.55-2.7	14L SOIC	0-70°C	X5643S14-2.7	X5645S14-2.7

Part Mark Information

X5643/45 W
X

P = 8-Lead PDIP
 S14 = 14 Lead SOIC

Blank = 5V ±10%, 0°C to +70°C, V_{TRIP} = 4.25-4.5
 AL = 5V ±10%, 0°C to +70°C, V_{TRIP} = 4.5-4.75
 I = 5V ±10%, -40°C to +85°C, V_{TRIP} = 4.25-4.5
 AM = 5V ±10%, -40°C to +85°C, V_{TRIP} = 4.5-4.75
 F = 2.7V to 5.5V, 0°C to +70°C, V_{TRIP} = 2.55-2.7
 AN = 2.7V to 5.5V, 0°C to +70°C, V_{TRIP} = 2.85-3.0
 G = 2.7V to 5.5V, -40°C to +85°C, V_{TRIP} = 2.55-2.7
 AP = 2.7V to 5.5V, -40°C to +85°C, V_{TRIP} = 2.85-3.0

All Intersil U.S. products are manufactured, assembled and tested utilizing ISO9000 quality systems.
 Intersil Corporation's quality certifications can be viewed at www.intersil.com/design/quality

Intersil products are sold by description only. Intersil Corporation reserves the right to make changes in circuit design, software and/or specifications at any time without notice. Accordingly, the reader is cautioned to verify that data sheets are current before placing orders. Information furnished by Intersil is believed to be accurate and reliable. However, no responsibility is assumed by Intersil or its subsidiaries for its use; nor for any infringements of patents or other rights of third parties which may result from its use. No license is granted by implication or otherwise under any patent or patent rights of Intersil or its subsidiaries.

For information regarding Intersil Corporation and its products, see www.intersil.com