

Excellent Integrated System Limited

Stocking Distributor

Click to view price, real time Inventory, Delivery & Lifecycle Information:

[STMicroelectronics](#)

[STH110N10F7-2](#)

For any questions, you can email us directly:

sales@integrated-circuit.com



STH110N10F7-2, STH110N10F7-6

N-channel 100 V, 4.9 mΩ typ., 110 A, STripFET™ F7
 Power MOSFETs in H²PAK-2 and H²PAK-6 packages

Datasheet - production data

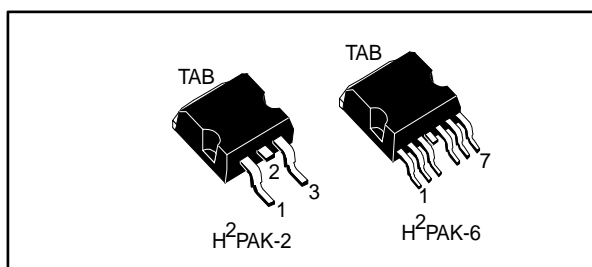
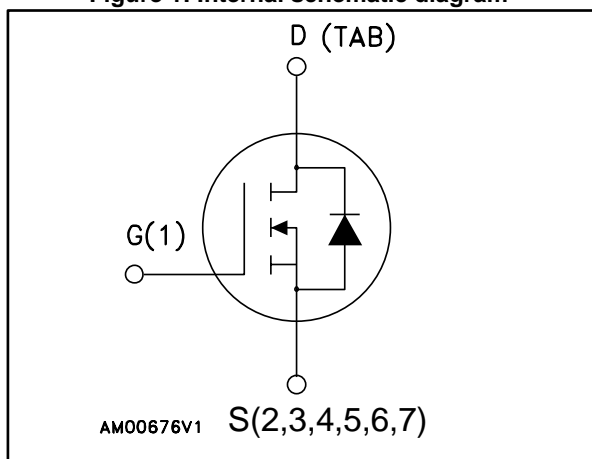

Figure 1: Internal schematic diagram



Features

Order code	V _{DS}	R _{DS(on)} max.	I _D	P _{TOT}
STH110N10F7-2	100 V	6.5 mΩ	110 A	150 W
STH110N10F7-6				

- Among the lowest R_{DS(on)} on the market
- Excellent figure of merit (FoM)
- Low C_{rss}/C_{iss} ratio for EMI immunity
- High avalanche ruggedness

Applications

- Switching applications

Description

These N-channel Power MOSFETs utilize STripFET™ F7 technology with an enhanced trench gate structure that results in very low on-resistance, while also reducing internal capacitance and gate charge for faster and more efficient switching.

Table 1: Device summary

Order code	Marking	Package	Packing
STH110N10F7-2	110N10F7	H ² PAK-2	Tape and reel
STH110N10F7-6		H ² PAK-6	

Contents

1	Electrical ratings	3
2	Electrical characteristics	4
	2.1 Electrical characteristics (curves)	6
3	Test circuits	8
4	Package information	9
	4.1 H ² PAK-2 package information.....	10
	4.2 H ² PAK-6 package information.....	13
	4.3 Packing information.....	16
5	Revision history	18

1 Electrical ratings

Table 2: Absolute maximum ratings

Symbol	Parameter	Value	Unit
V_{DS}	Drain-source voltage	100	V
V_{GS}	Gate-source voltage	± 20	V
$I_D^{(1)}$	Drain current (continuous) at $T_C = 25\text{ }^\circ\text{C}$	110	A
$I_D^{(1)}$	Drain current (continuous) at $T_C = 100\text{ }^\circ\text{C}$	76	A
$I_D^{(2)}$	Drain current (continuous) at $T_{pcb} = 25\text{ }^\circ\text{C}$	18	A
$I_D^{(2)}$	Drain current (continuous) at $T_{pcb} = 100\text{ }^\circ\text{C}$	13	A
$I_{DM}^{(3)}$	Drain current (pulsed)	430	A
$P_{TOT}^{(1)}$	Total dissipation at $T_C = 25\text{ }^\circ\text{C}$	150	W
$E_{AS}^{(4)}$	Single pulse avalanche energy	490	mJ
T_J	Operating junction temperature	-55 to 175	$^\circ\text{C}$
T_{stg}	Storage temperature		$^\circ\text{C}$

Notes:

- (1) This value is rated according to R_{thj-c}
- (2) This value is rated according to $R_{thj-pcb}$
- (3) Pulse width limited by safe operating area
- (4) Starting $T_J = 25\text{ }^\circ\text{C}$, $I_D = 18$, $V_{DD} = 50\text{ V}$

Table 3: Thermal resistance

Symbol	Parameter	Value	Unit
$R_{thj-case}$	Thermal resistance junction-case	1	$^\circ\text{C/W}$
$R_{thj-pcb}^{(1)}$	Thermal resistance junction-pcb	35	$^\circ\text{C/W}$

Notes:

- (1) When mounted on FR-4 board of 1 inch², 2 oz Cu

Electrical characteristics

STH110N10F7-2, STH110N10F7-6

2 Electrical characteristics

(T_{CASE} = 25 °C unless otherwise specified)

Table 4: On/off-state

Symbol	Parameter	Test conditions	Min.	Typ.	Max.	Unit
V _{(BR)DSS}	Drain-source breakdown voltage (V _{GS} = 0)	I _D = 250 μA	100			V
I _{DSS}	Zero gate voltage drain current (V _{GS} = 0)	V _{DS} = 100 V			1	μA
		V _{DS} = 100 V; T _C = 125 °C			100	μA
I _{GSS}	Gate body leakage current (V _{DS} = 0)	V _{GS} = 20 V			100	nA
V _{GS(th)}	Gate threshold voltage	V _{DS} = V _{GS} , I _D = 250 μA	2.5		4.5	V
R _{DS(on)}	Static drain-source on-resistance	V _{GS} = 10 V, I _D = 55 A		4.9	6.5	mΩ

Table 5: Dynamic

Symbol	Parameter	Test conditions	Min.	Typ.	Max.	Unit	
C _{iss}	Input capacitance	V _{DS} = 50 V, f = 1 MHz, V _{GS} = 0	-	5117	-	pF	
C _{oss}	Output capacitance			992		pF	
C _{riss}	Reverse transfer capacitance			39		pF	
Q _g	Total gate charge			V _{DD} = 50 V, I _D = 110 A		72	nC
Q _{gs}	Gate-source charge			V _{GS} = 10 V		31	nC
Q _{gd}	Gate-drain charge			See Figure 14: "Gate charge test circuit"		16	nC

Table 6: Switching times

Symbol	Parameter	Test conditions	Min.	Typ.	Max.	Unit
t _{d(on)}	Turn-on delay time	V _{DD} = 50 V, I _D = 55 A, R _G = 4.7 Ω, V _{GS} = 10 V See Figure 13: "Switching times test circuit for resistive load"	-	25	-	ns
t _r	Rise time			36		ns
t _{d(off)}	Turn-off delay time			52		ns
t _f	Fall time			21		ns

STH110N10F7-2, STH110N10F7-6

Electrical characteristics

Table 7: Source-drain diode

Symbol	Parameter	Test conditions	Min.	Typ.	Max.	Unit
I_{SD}	Source-drain current				110	A
$I_{SDM}^{(1)}$	Source-drain current (pulsed)				430	A
$V_{SD}^{(2)}$	Forward on voltage	$I_{SD} = 55\text{ A}, V_{GS} = 0$			1.2	V
t_{rr}	Reverse recovery time	$I_{SD} = 110\text{ A},$ $di/dt = 100\text{ A}/\mu\text{s},$ $V_{DD} = 80\text{ V},$ $T_j = 150\text{ }^\circ\text{C}$	-	77		ns
Q_{rr}	Reverse recovery charge			150		nC
I_{RRM}	Reverse recovery current			4.3		A

Notes:

⁽¹⁾Pulse width limited by safe operating area

⁽²⁾Pulsed: pulse duration = 300 μs , duty cycle 1.5%

Electrical characteristics

STH110N10F7-2, STH110N10F7-6

2.1 Electrical characteristics (curves)

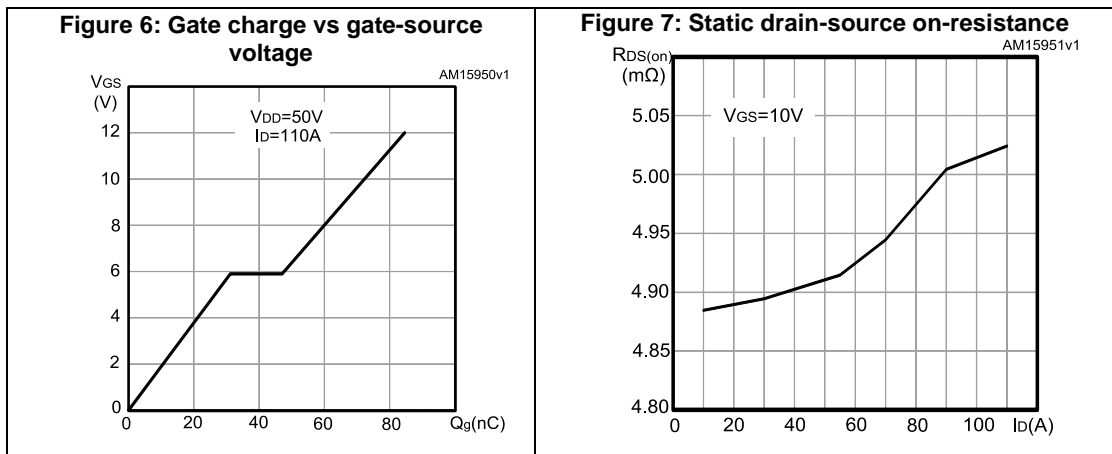
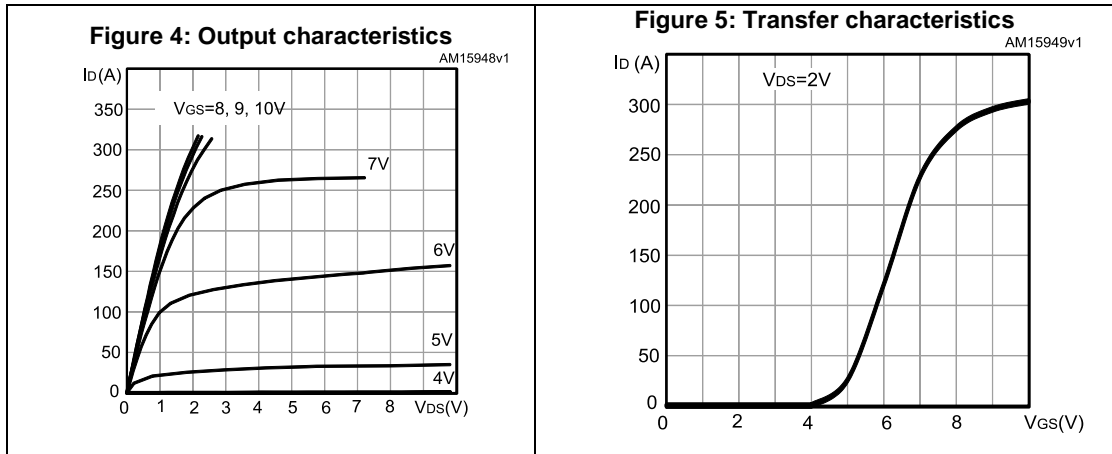
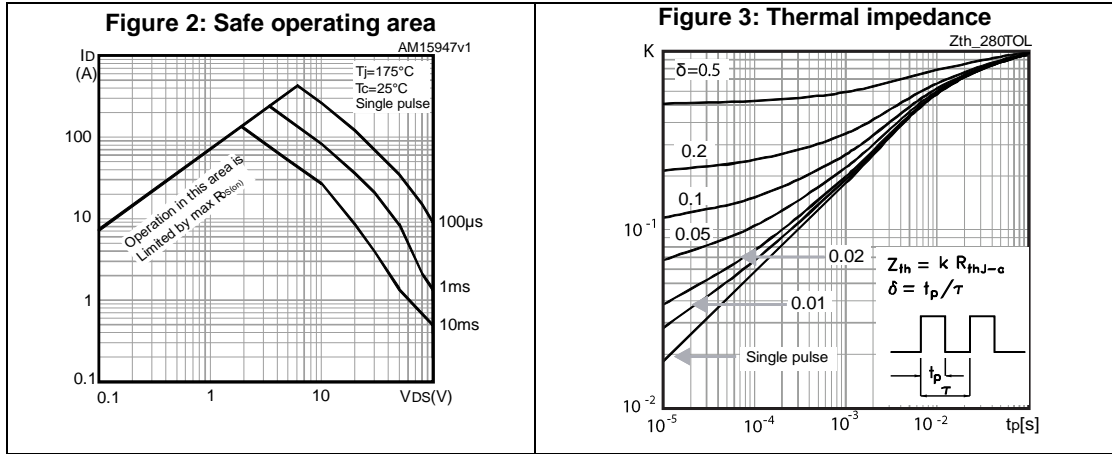

STH110N10F7-2, STH110N10F7-6

Electrical characteristics

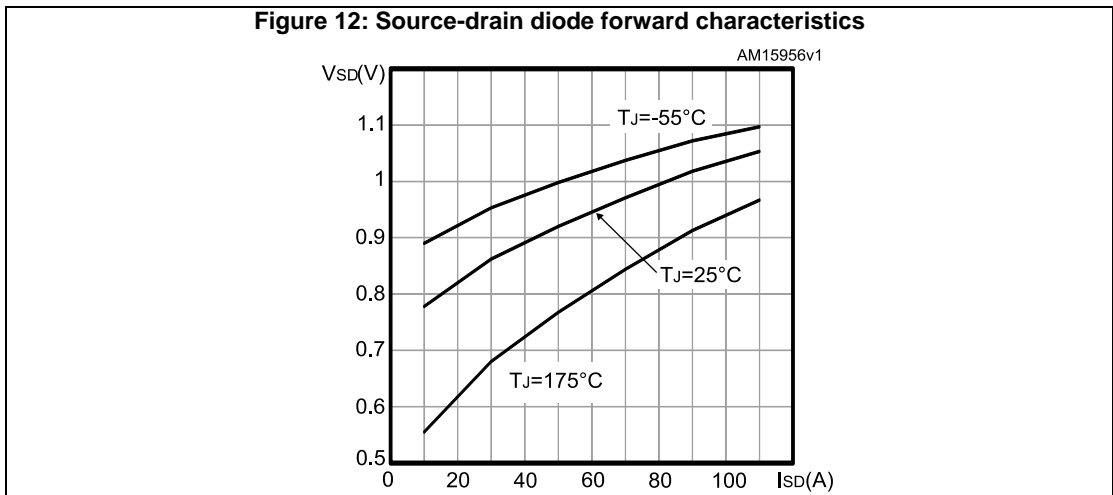
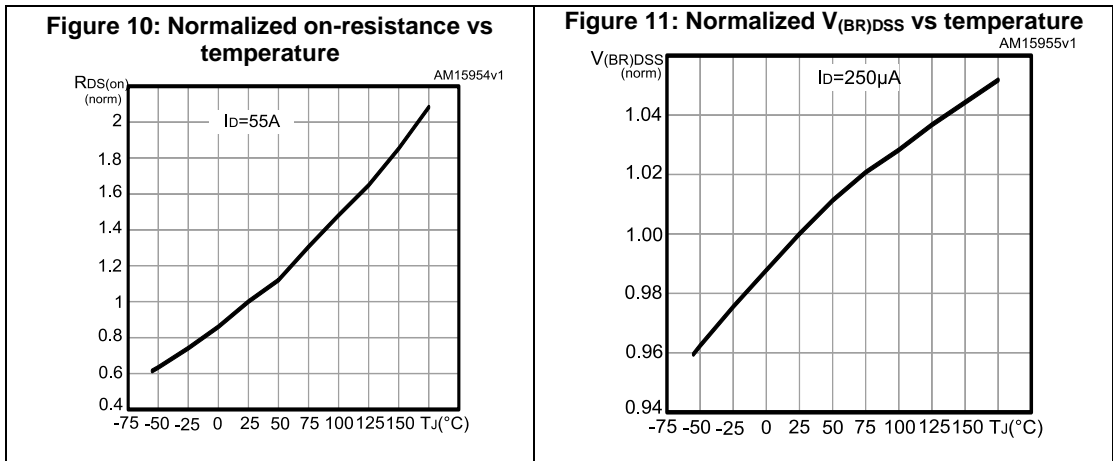
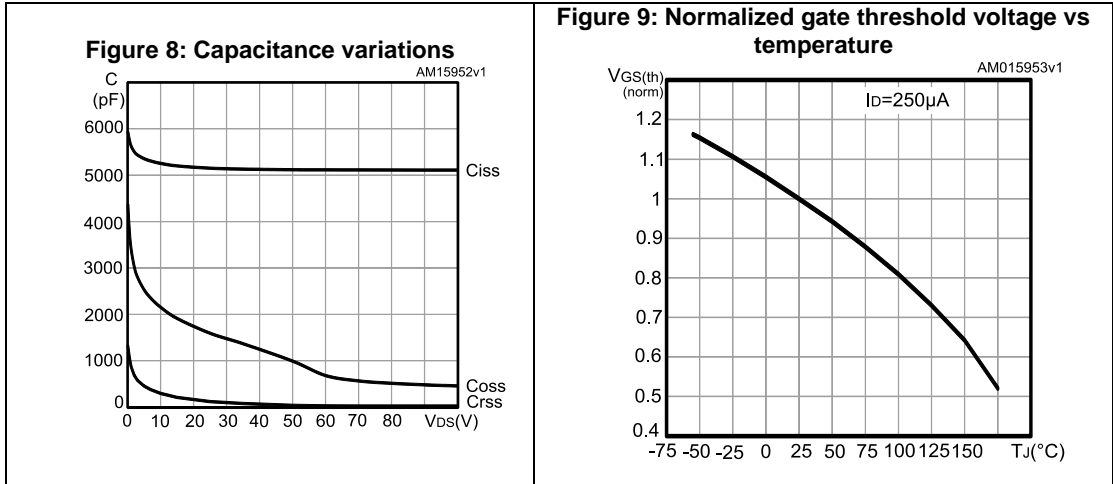

Test circuits

STH110N10F7-2, STH110N10F7-6

3 Test circuits

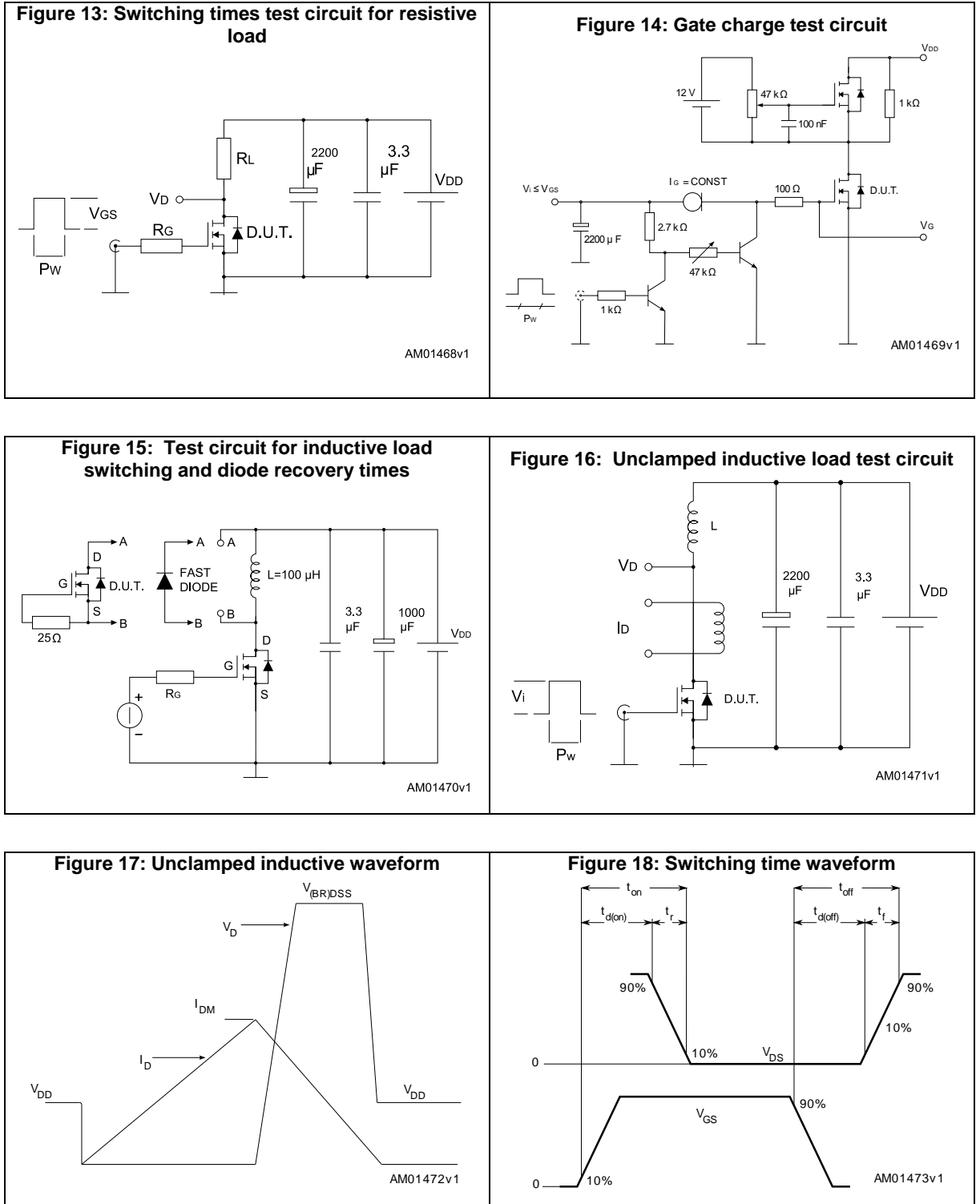

4 Package information

In order to meet environmental requirements, ST offers these devices in different grades of ECOPACK[®] packages, depending on their level of environmental compliance. ECOPACK[®] specifications, grade definitions and product status are available at: www.st.com. ECOPACK[®] is an ST trademark.

Package information

STH110N10F7-2, STH110N10F7-6

4.1 H²PAK-2 package information

Figure 19: H²PAK-2 outline

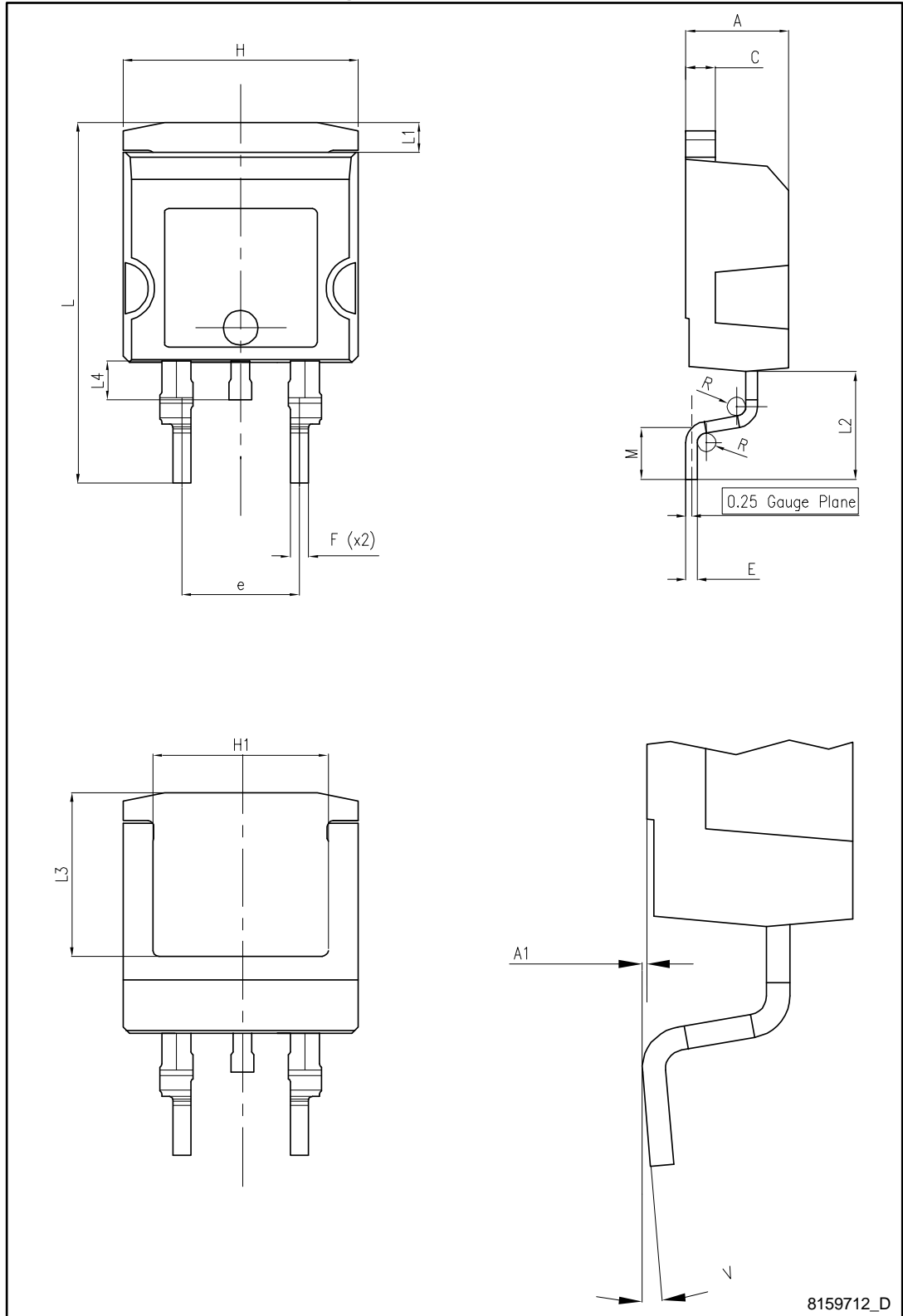

STH110N10F7-2, STH110N10F7-6

Package information

Table 8: H²PAK-2 mechanical data

Dim.	mm		
	Min.	Typ.	Max.
A	4.30		4.80
A1	0.03		0.20
C	1.17		1.37
e	4.98		5.18
E	0.50		0.90
F	0.78		0.85
H	10.00		10.40
H1	7.40		7.80
L	15.30		15.80
L1	1.27		1.40
L2	4.93		5.23
L3	6.85		7.25
L4	1.5		1.7
M	2.6		2.9
R	0.20		0.60
V	0°		8°

Package information

STH110N10F7-2, STH110N10F7-6

Figure 20: H²PAK-2 recommended footprint

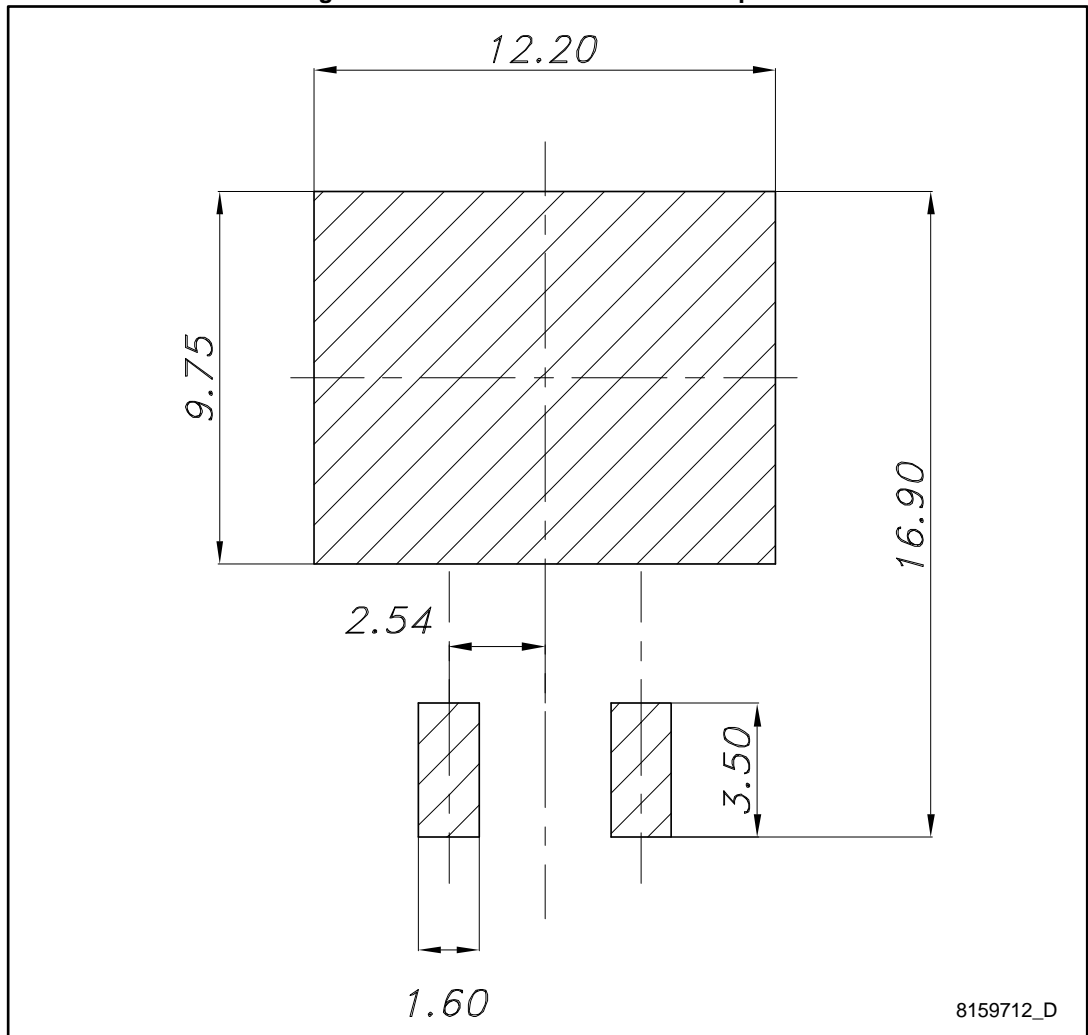

8159712_D

STH110N10F7-2, STH110N10F7-6

Package information

4.2 H²PAK-6 package information

Figure 21: H²PAK-6 outline

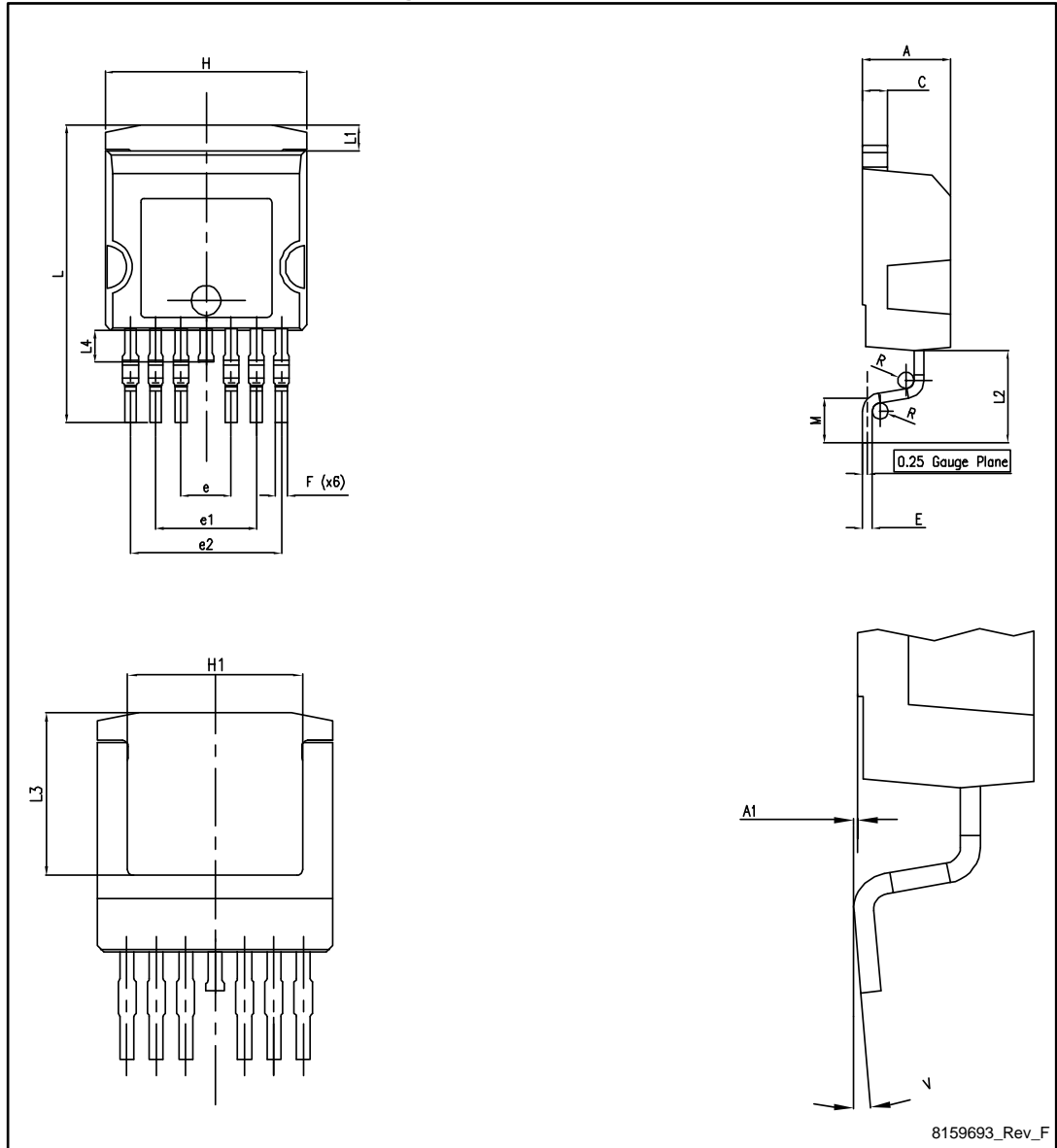

Package information

STH110N10F7-2, STH110N10F7-6

Table 9: H²PAK-6 mechanical data

Dim.	mm		
	Min.	Typ.	Max.
A	4.30		4.80
A1	0.03		0.20
C	1.17		1.37
e	2.34		2.74
e1	4.88		5.28
e2	7.42		7.82
E	0.45		0.60
F	0.50		0.70
H	10.00		10.40
H1	7.40		7.80
L	14.75		15.25
L1	1.27		1.40
L2	4.35		4.95
L3	6.85		7.25
L4	1.5		1.75
M	1.90		2.50
R	0.20		0.60
V	0°		8°

STH110N10F7-2, STH110N10F7-6

Package information

Figure 22: H²PAK-6 recommended footprint

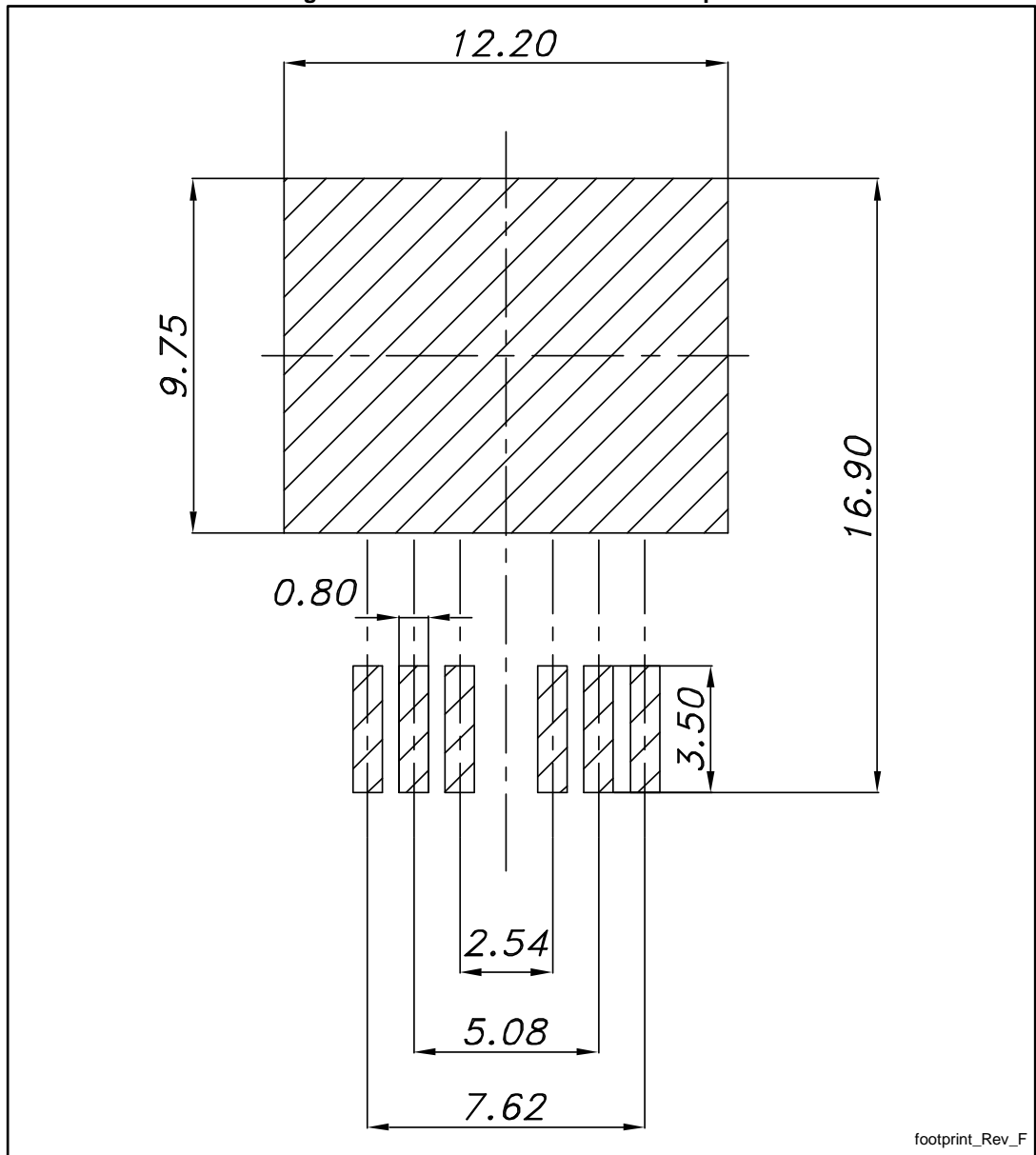

Dimensions are in mm.

Package information

STH110N10F7-2, STH110N10F7-6

4.3 Packing information

Figure 23: Tape outline

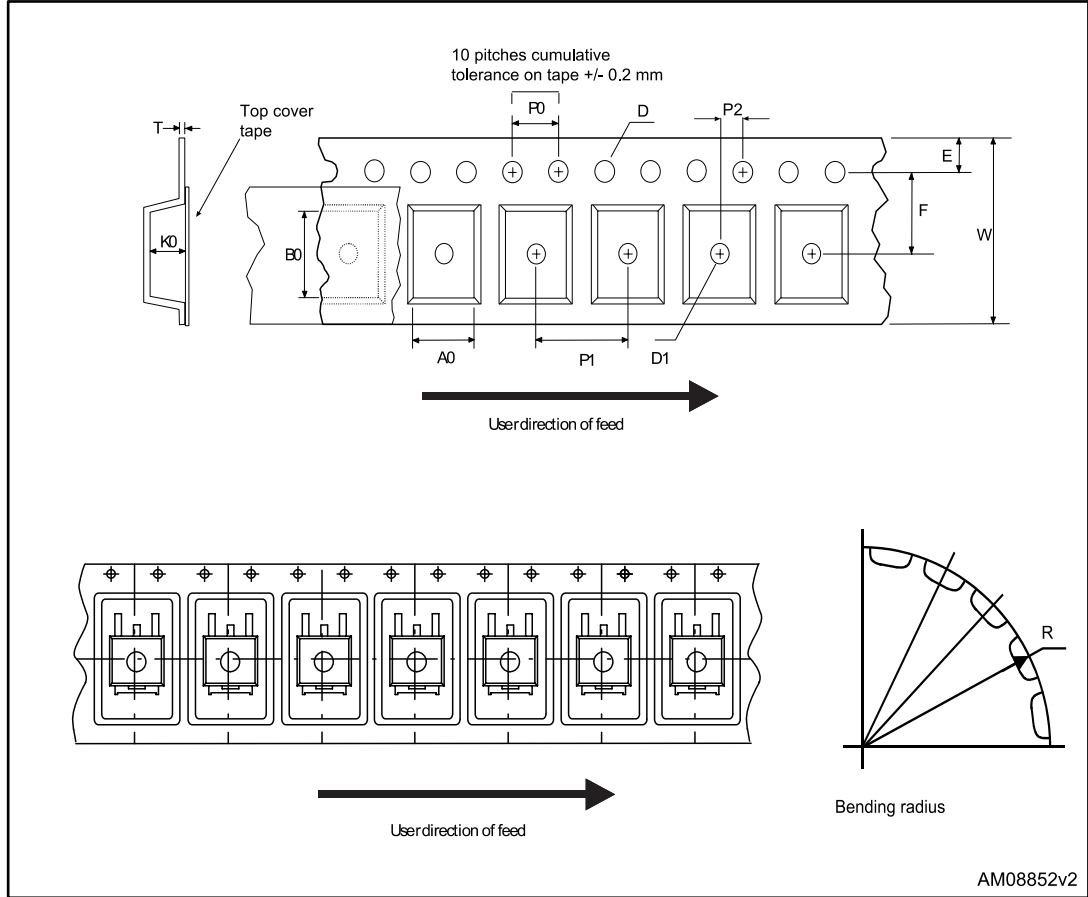

AM08852v2

Figure 24: Reel outline

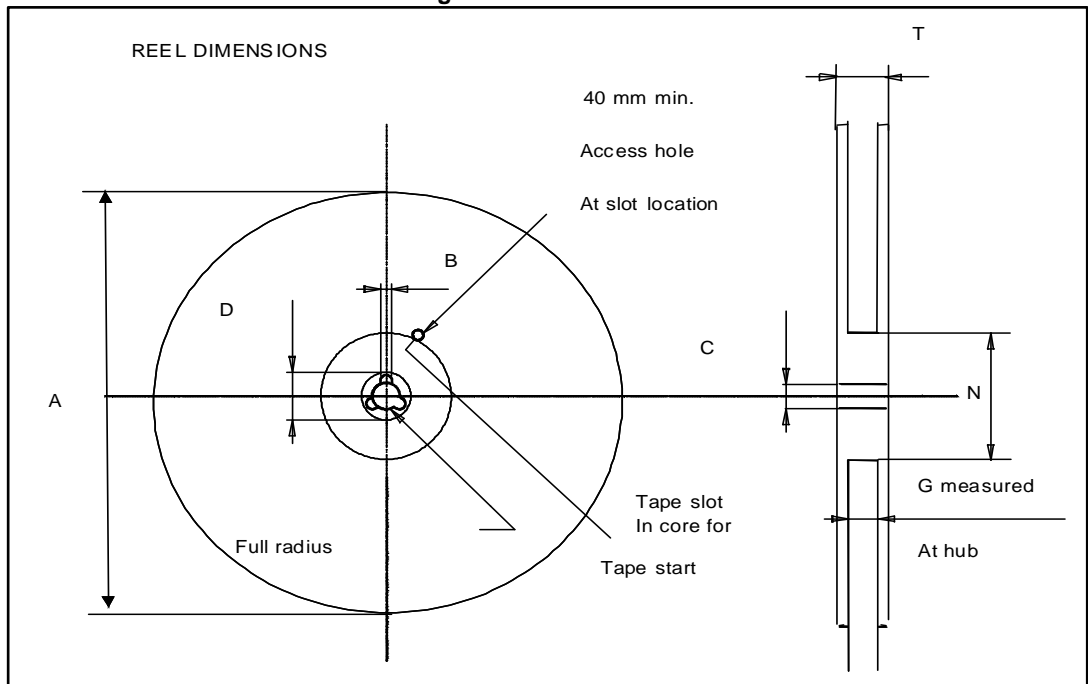

STH110N10F7-2, STH110N10F7-6

Package information

Table 10: Tape and reel mechanical data

Tape			Reel		
Dim.	mm		Dim.	mm	
	Min.	Max.		Min.	Max.
A0	10.5	10.7	A		330
B0	15.7	15.9	B	1.5	
D	1.5	1.6	C	12.8	13.2
D1	1.59	1.61	D	20.2	
E	1.65	1.85	G	24.4	26.4
F	11.4	11.6	N	100	
K0	4.8	5.0	T		30.4
P0	3.9	4.1			
P1	11.9	12.1	Base quantity		1000
P2	1.9	2.1	Bulk quantity		1000
R	50				
T	0.25	0.35			
W	23.7	24.3			

5 Revision history

Table 11: Document revision history

Date	Revision	Changes
10-Dec-2012	1	Initial release. Part number (STH110N10F7-2) previously included in datasheet ID024005
16-Jul-2013	2	<ul style="list-style-type: none"> Modified: title Modified: I_{DM} value in Table 2: "Absolute maximum ratings", the entire typical values in Table 5: "Dynamic", Table 6: "Switching times" and Table 7: "Source-drain diode" Minor text changes
11-Nov-2014	3	<ul style="list-style-type: none"> Updated: H²PAK-6 package information. Updated the title, features and description. Minor text changes.
26-Nov-2014	4	Changed from Figure 2: "Safe operating area" to Figure 12: "Source-drain diode forward characteristics" .

STH110N10F7-2, STH110N10F7-6

IMPORTANT NOTICE – PLEASE READ CAREFULLY

STMicroelectronics NV and its subsidiaries (“ST”) reserve the right to make changes, corrections, enhancements, modifications, and improvements to ST products and/or to this document at any time without notice. Purchasers should obtain the latest relevant information on ST products before placing orders. ST products are sold pursuant to ST’s terms and conditions of sale in place at the time of order acknowledgement.

Purchasers are solely responsible for the choice, selection, and use of ST products and ST assumes no liability for application assistance or the design of Purchasers’ products.

No license, express or implied, to any intellectual property right is granted by ST herein.

Resale of ST products with provisions different from the information set forth herein shall void any warranty granted by ST for such product.

ST and the ST logo are trademarks of ST. All other product or service names are the property of their respective owners.

Information in this document supersedes and replaces information previously supplied in any prior versions of this document.

© 2014 STMicroelectronics – All rights reserved