

Excellent Integrated System Limited

Stocking Distributor

Click to view price, real time Inventory, Delivery & Lifecycle Information:

[Vicor Corporation](#)
[30090](#)

For any questions, you can email us directly:

sales@integrated-circuit.com



Distributor of Vicor Corporation: Excellent Integrated System Limited

Datasheet of 30090 - HEATSINK VI-200 TRANSVERSE 0.9"

Contact us: sales@integrated-circuit.com Website: www.integrated-circuit.com

VICOR CONFIDENTIAL

THIS DOCUMENT AND THE DATA DISCLOSED HEREIN OR HEREWITH IS NOT TO BE REPRODUCED, USED, OR DISCLOSED IN WHOLE OR IN PART TO ANYONE WITHOUT PERMISSION OF VICOR CORP.

REV.	DESCRIPTION	DATE	APPROVED
1	RELEASED PER E050350	LEK 11/16/05	EF

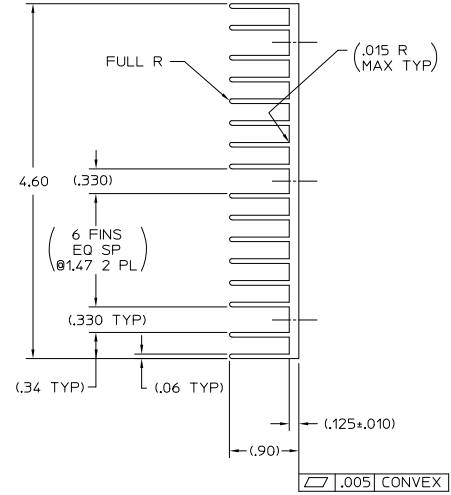
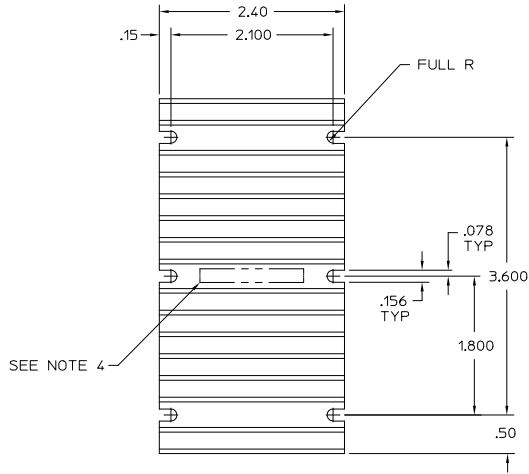

NOTES:

1. MATERIAL: 6063-T5 ALUMINUM.
2. REMOVE ALL LOOSE AND HANGING BURRS, OTHERWISE, BURRS SHALL NOT EXCEED .003.
3. CLEAR FINISH, RoHS COMPLIANT, CHROMIUM FREE PER CST-0001, LATEST REVISION.
4. PERMANENTLY MARK PART NUMBER AND REVISION LEGIBLY IN AREA SHOWN.
5. O DENOTES CRITICAL CHARACTERISTIC FOR LOT INSPECTION.
6. TOLERANCE ON ALL DIMENSIONS SHOWN AS REFERENCE SHALL FOLLOW STANDARD ALUMINUM ASSOCIATION TOLERANCE.

FREE CONVECTION	2.4
200 LFM	1.52
600 LFM	0.72

DRAWN BY LKNIGHT	DATE 05/19/05	HEATSINK .9" HGT., VERT.		
UNLESS OTHERWISE SPECIFIED DIMENSIONS ARE IN INCHES TOLERANCES ARE: FRACTIONS DECIMALS ANGLES +1/64 .XX .01 °1P XXX-.005				
THIRD ANGLE PROJECTION 	SIZE C	FSCM NO. 87131	DWG NO. 30090	REV 1
DO NOT SCALE DRAWING	SCALE FULL	SHEET 1 OF 1		