

Excellent Integrated System Limited

Stocking Distributor

Click to view price, real time Inventory, Delivery & Lifecycle Information:

[Vicor Corporation](#)
[30198](#)

For any questions, you can email us directly:
sales@integrated-circuit.com

VICOR CONFIDENTIAL
 THIS DOCUMENT AND THE DATA DISCLOSED
 HEREIN OR HEREWITH IS NOT TO BE REPRODUCED,
 USED, OR DISCLOSED IN WHOLE OR IN PART
 TO ANYONE WITHOUT PERMISSION OF VICOR CORP.

REV.	DESCRIPTION	DATE	APPROVED
1	RELEASED PER E050355	LEK 11/17/05	EF

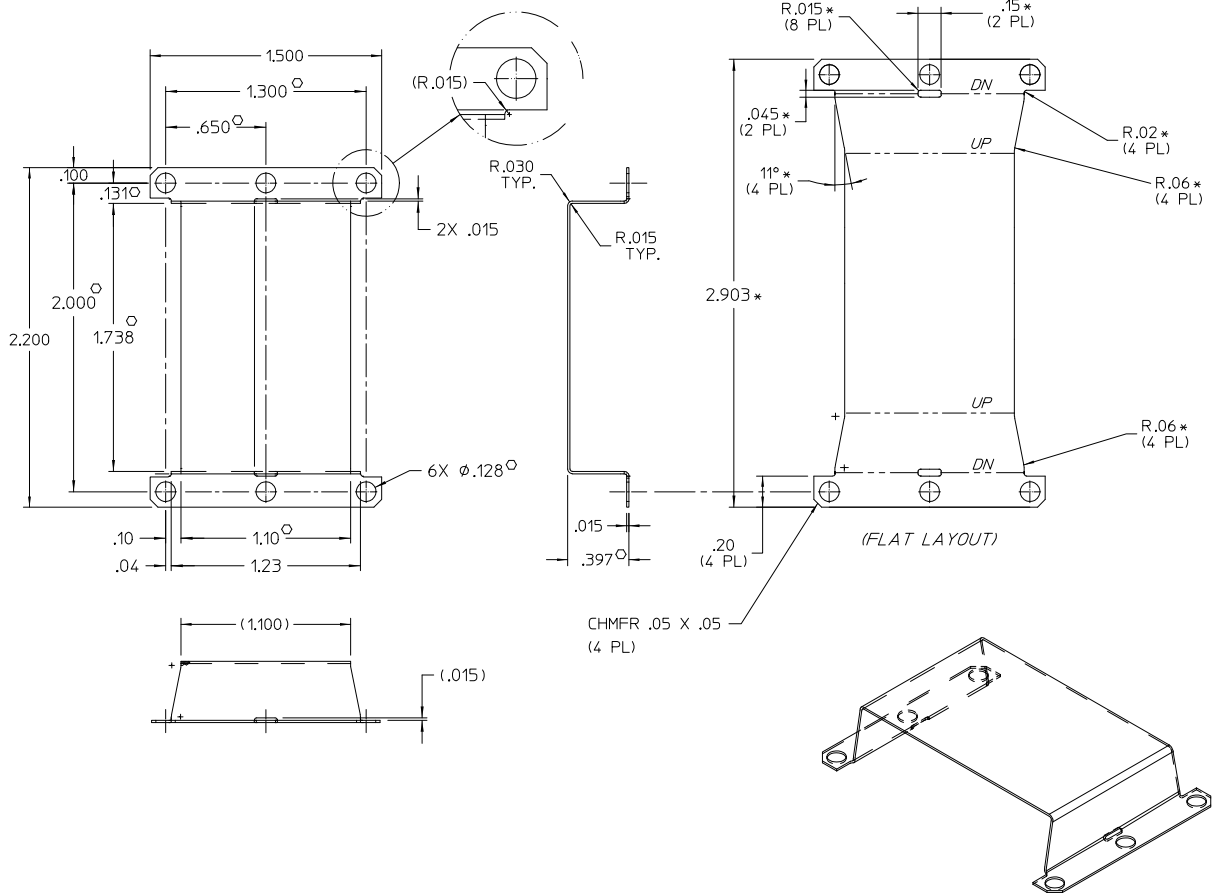

NOTES:

1. MATERIAL: ALUMINUM- (.015) THK, 5052
2. REMOVE BURRS & SHARP EDGES
3. "*" DIMENSIONS ARE NOT FOR VICOR INSPECTION.
4. O DENOTES CRITICAL CHARACTERISTICS FOR LOT INSPECTION.
5. CLEAR FINISH, RoHS COMPLIANT, CHROMIUM FREE PER CST-0001, LATEST REVISION

DRAWN BY	DATE	VICOR	
P.E.IBNI	07/05/05	SHIELD BASE PLATE SLOTTED (MINI)	
UNLESS OTHERWISE SPECIFIED DIMENSIONS ARE IN INCHES TOLERANCES ARE: FRACTIONS DECIMALS ANGLES +1/64 .XX .01 .1°			
THIRD ANGLE PROJECTION	SIZE	FSCM NO.	DWG NO.
	C	67131	30198
DO NOT SCALE DRAWING	SCALE	2:1	SHEET 1 OF 1