



Excellent Integrated System Limited

Stocking Distributor

Click to view price, real time Inventory, Delivery & Lifecycle Information:

[Essentra Components \(formerly Richco, Inc.\)](#)
[DLCBS3-3-01](#)

For any questions, you can email us directly:
sales@integrated-circuit.com

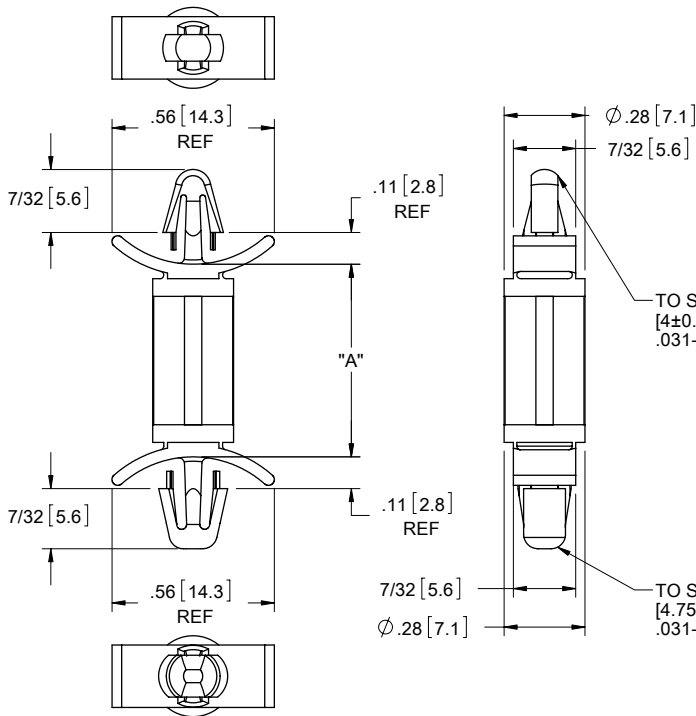

MATERIAL: NYLON 6/6 UL 94 V-2 (RMS-01) COLOR: NATURAL PART NO.	MATERIAL: NYLON 6/6 UL 94 V-0 (RMS-19) COLOR: NATURAL PART NO.	DIM. "A"±.015 [0.4]
DLCBS3-3-01	DLCBS3-3-19	3/16 [4.8]
DLCBS3-4-01	DLCBS3-4-19	1/4 [6.4]
DLCBS3-6-01	DLCBS3-6-19	3/8 [9.5]
DLCBS3-8-01	DLCBS3-8-19	1/2 [12.7]
DLCBS3-10-01	DLCBS3-10-19	5/8 [15.9]
DLCBS3-12-01	DLCBS3-12-19	3/4 [19.1]
DLCBS3-14-01	DLCBS3-14-19	7/8 [22.2]

TO SNAP-LOCK IN A .156±.003
 [4±0.08] DIA. HOLE, IN A
 .031-.078 [0.79-1.98] PANEL THICKNESS

TO SNAP-LOCK IN A .187±.003
 [4.75±0.08] DIA. HOLE, IN A
 .031-.078 [0.79-1.98] PANEL THICKNESS



- NOTES:
- MATERIAL: NYLON 6/6 UL 94 HB (RMS-73)
 COLOR: NATURAL.
 AVAILABLE BY SPECIAL ORDER ONLY.
 TO ORDER USE P/N DLCBS3-X-73
 - MATERIAL: NYLON 6/6, UL 94 V-0, UV STABILIZED, (RMS-46)
 COLOR: BLACK.
 AVAILABLE BY SPECIAL ORDER ONLY.
 TO ORDER USE P/N: DLCBS3-X-UVB
 - ALTERNATE UNITS FOR REFERENCE ONLY.

AVAILABLE BY SPECIAL ORDER- NAFTA REGION ONLY

G		REDRAWN, SEE ECN #1208 FOR CHANGES	SK	11/29/06	TITLE: DUAL LOCKING CIRCUIT BOARD SUPPORT, TYPE 3				DWG IN IN [MM]	FINAL	PRINT TYPE
-		SEE ENGINEERING FOR REVISIONS A-F			FILE #: DLCBS3	DWN: SK	APP: RT				
REV.		DESCRIPTION	ENGR.	DATE	SHEET: 1 OF 1	SHEET SIZE: A	DT: 11/27/06	CHKD: SJ	PART #	CA	
					RE: RICHCO, INC.	RICHCO, INC. ENG@RICHCO-INC.COM (773) 539-4060		SEE TABLE			