

Excellent Integrated System Limited

Stocking Distributor

Click to view price, real time Inventory, Delivery & Lifecycle Information:

[E-Switch](#)
[100DP8T6B11M2QEH](#)

For any questions, you can email us directly:

sales@integrated-circuit.com

SHEET 1 OF 1

SWITCH FUNCTION		
POS. 1	POS. 2	POS. 3
(ON)	ON	(ON)
2-3, 5-6	2-3, 5-4	2-1, 5-4

(ON) = MOMENTARY

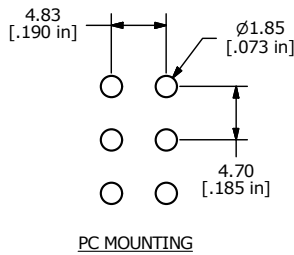

PC MOUNTING

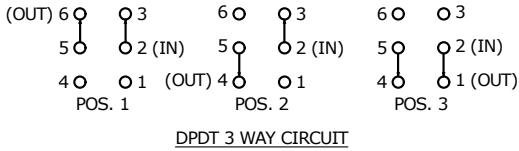
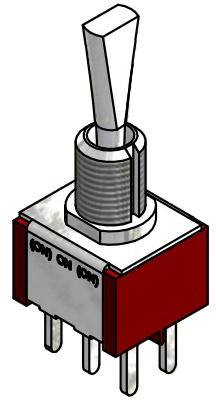
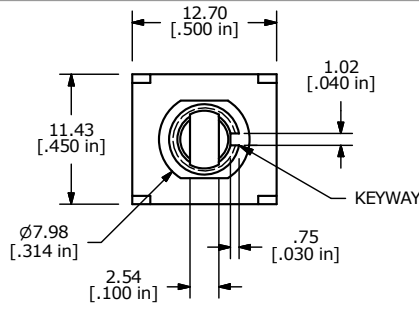

DPDT 3 WAY CIRCUIT

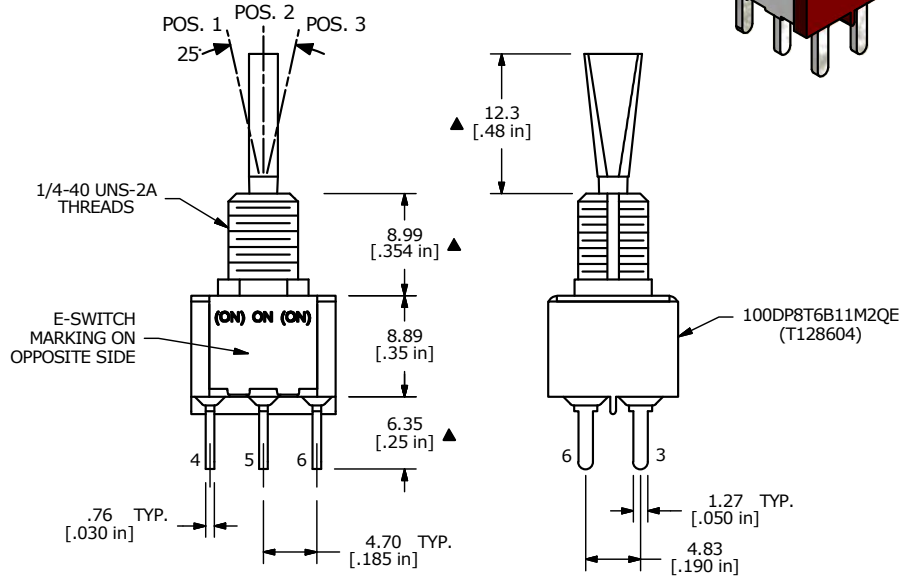

- NOTE:
1. ALL DIMENSIONS IN MM [INCH]
 2. GENERAL TOLERANCE: X.X = ±0.4
X.XX = ±0.25
 3. TERMINAL NUMBERS FOR REF ONLY
 - ▲ 4. PLATING MATERIAL: SILVER
 5. RATING: 5 AMPS W/RESISTIVE LOAD @ 120VAC OR 28VDC
2 AMPS W/RESISTIVE LOAD @ 250VAC
 6. ELECTRIC LIFE: 40,000 make-and-break cycles at full load.
 7. INSULATION RESISTANCE: 1,000 Mega-ohm min.
 8. DIELECTRIC STRENGTH: 1,000 V RMS @sea level.
 9. OPERATING TEMP.: -30°C to 85°C
 10. HARDWARE TO BE SHIPPED BULK
T100000 - HEXNUT - QTY 2
T100011 - LOCKWASHER - QTY 1
T100015 - LOCKRING - QTY 1
 11. ▲ DENOTES CRITICAL PARAMETER.

C	22340	Updated Terminal Numbers	6/7/16	MW
B	15028	CORRECTED SWITCH FUNCTION	6/23/05	JB
A	14874	CREATED DRAWING	4/21/05	JB
REV	PCR NO	DESCRIPTION	DATE	BY

THE INFORMATION CONTAINED IN THIS DOCUMENT IS PROPRIETARY TO E-SWITCH AND IS NOT TO BE COPIED OR TRANSFERRED

TITLE 100DP8T6B11M2QE				
SCALE	DATE	DR	DWG	REV
2:1	4/21/2005	JB	ST128604	C