

Excellent Integrated System Limited

Stocking Distributor

Click to view price, real time Inventory, Delivery & Lifecycle Information:

[Fairchild Semiconductor](#)
[QVE00120](#)

For any questions, you can email us directly:

sales@integrated-circuit.com

QVE00120

OPTOLOGIC® OPTICAL INTERRUPTER SWITCH

PACKAGE DIMENSIONS

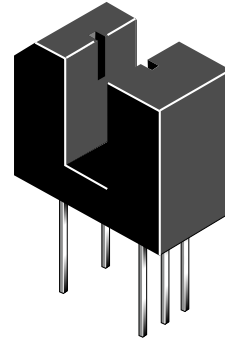
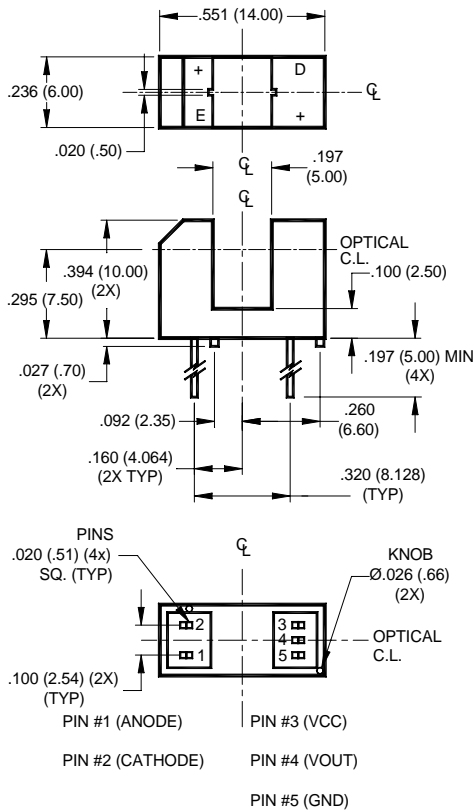

FEATURES

- No contact switching
- 5.0 mm wide slot
- 0.5 mm aperture width
- Opaque black plastic housing
- Output configuration: Buffer open-collector
- TTL/CMOS compatible output
- Locating knobs on housing base for accurate mounting

NOTES (Applies to Max Ratings and Characteristics Tables.)

1. Derate power dissipation linearly 1.67 mW/°C above 25°C.
2. Derate power dissipation linearly 2.50 mW/°C above 25°C.
3. RMA flux is recommended.
4. Methanol or isopropyl alcohols are recommended as cleaning agents.
5. Soldering iron 1/16" (1.6mm) from housing.
6. As long as leads are not under any stress or spring tension.

NOTES:

1. Dimensions for all drawings are in inches (millimeters).
2. Tolerance of $\pm .010 (.25)$ on all non-nominal dimensions unless otherwise specified.

ABSOLUTE MAXIMUM RATINGS ($T_A = 25^\circ\text{C}$ unless otherwise specified)

Parameter	Symbol	Rating	Units
Operating Temperature	T_{OPR}	-40 to +85	°C
Storage Temperature	T_{STG}	-40 to +85	°C
Lead Temperature (Solder Iron) ^(3,4,5,6)	T_{SOL-I}	240 for 5 sec	°C
Lead Temperature (Solder Flow) ^(3,4,5,6)	T_{SOL-F}	260 for 10 sec	°C
EMITTER			
Continuous Forward Current	I_F	50	mA
Reverse Voltage	V_R	5	V
Power Dissipation ⁽¹⁾	P_D	100	mW
SENSOR			
Output Current	I_O	50	mA
Supply Voltage	V_{CC}	16	V
Output Voltage	V_O	30	V
Power Dissipation ⁽²⁾	P_D	150	mW

QVE00120

OPTOLOGIC® OPTICAL INTERRUPTER SWITCH

ELECTRICAL / OPTICAL CHARACTERISTICS (T _A =25°C)						
PARAMETER	TEST CONDITIONS	SYMBOL	MIN.	TYP.	MAX.	UNITS
Operating Supply Voltage		V _{CC}	4.5		16	V
INPUT DIODE						
Forward Voltage	I _F = 20 mA	V _F	—		1.7	V
Reverse Leakage Current	V _R = 5 V	I _R	—		10	μA
COUPLED						
Operating Supply Current	I _F = 15 mA or 0 mA, V _{CC} = 16 V	I _{CC}	—		5	mA
Low Level Output Voltage	I _F = 15 mA, V _{CC} = 5 V, R _L = 360 Ω	V _{OL}	—		0.4	V
High Level Output Current	I _F = 0 mA, V _{CC} = 5 V, V _{OH} = 30 V	I _{OH}	—		100	μA
Turn on Threshold Current	V _{CC} = 5 V, R _L = 360 Ω	I _F (+)	—		15	mA
Turn off Threshold Current	V _{CC} = 5 V, R _L = 360 Ω	I _F (-)	0.50		—	mA
Hysteresis Ratio		I _F (+) / I _F (-)		1.2		
Propagation Delay	V _{CC} = 5 V, R _L = 360 Ω	t _{PLH} , t _{PHL}		5		μs
Output Rise and Fall Time	V _{CC} = 5 V, R _L = 360 Ω	t _r , t _f		70		ns

TYPICAL PERFORMANCE CURVES

Fig. 1 Output Voltage vs. Input Current

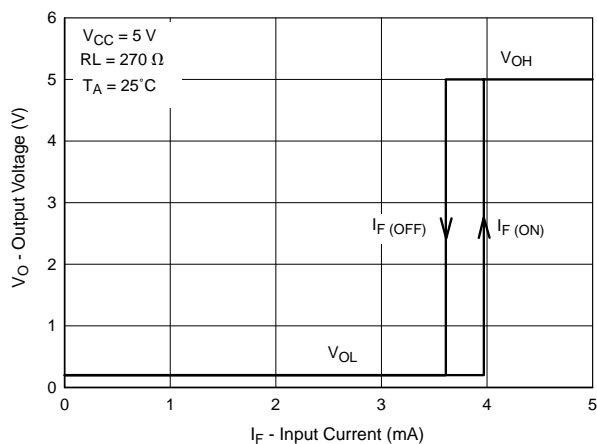
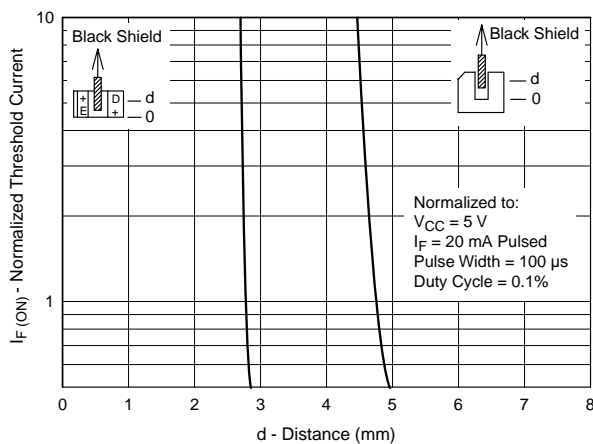

Fig. 2 Normalized Threshold Current vs. Shield Distance



QVE00120

OPTOLOGIC® OPTICAL INTERRUPTER SWITCH

Fig. 3 Normalized Threshold Current vs. Supply Voltage

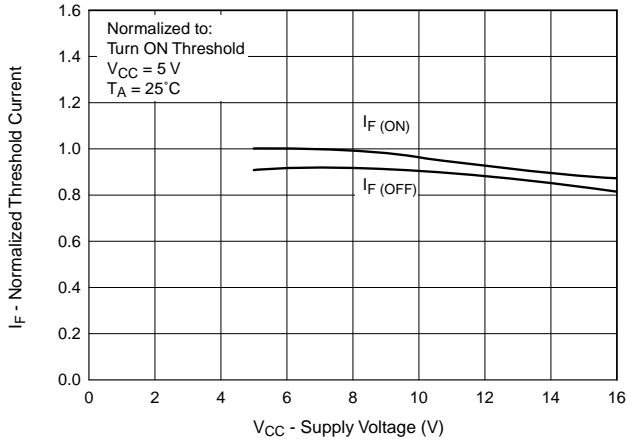

Fig. 4 Normalized Threshold Current vs. Ambient Temperature

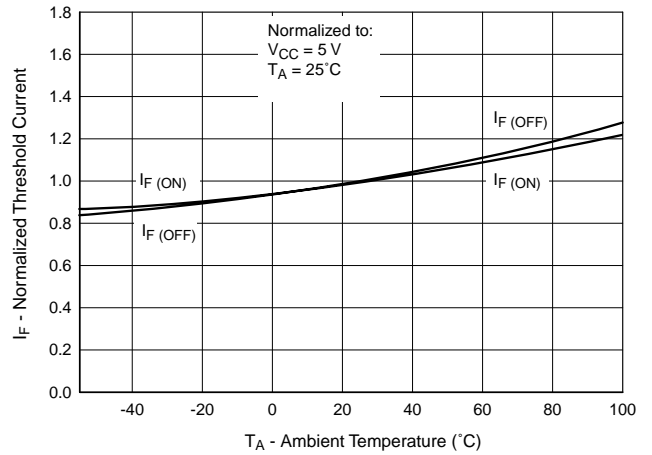

Fig. 5 Forward Current vs. Forward Voltage

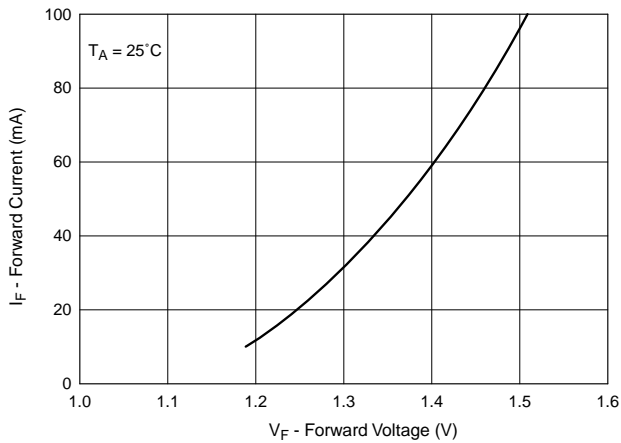

Fig. 6 Low Output Voltage vs. Output Current

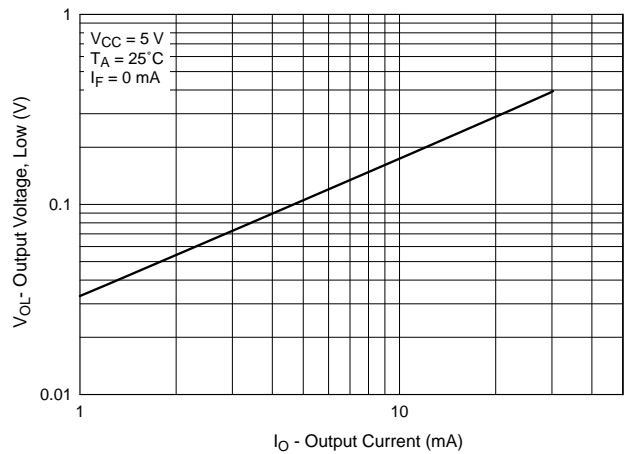
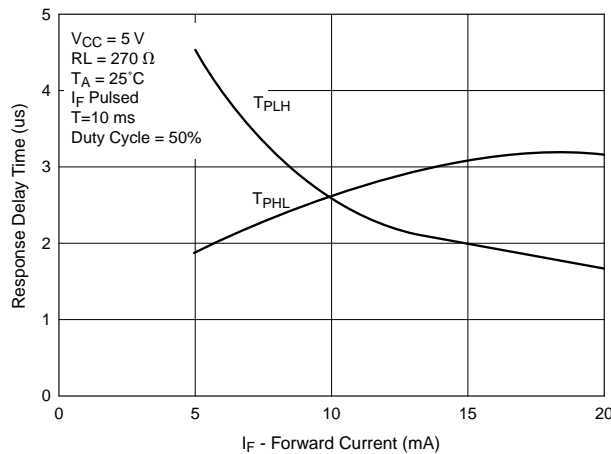

Fig. 7 Response Time vs. Forward Current



QVE00120

OPTOLOGIC® OPTICAL INTERRUPTER SWITCH

Fig. 8 Switching Speed Test Circuit

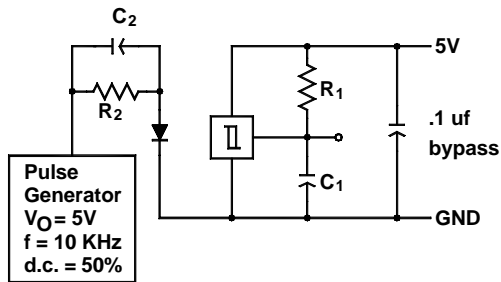

$R_1 = 270 \Omega$
 $R_2 = 360 \Omega$

$C_1 = 15 \text{ pf}$
 $C_2 = 20 \text{ pf}$

C_1 and C_2 include probe and stray wire capacitance

Fig. 9 Typical Operating Circuit

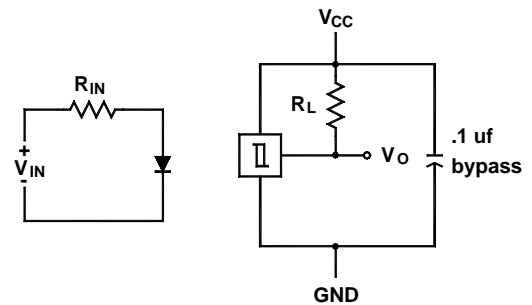

Fig. 10 Switching Test Curve for Buffers

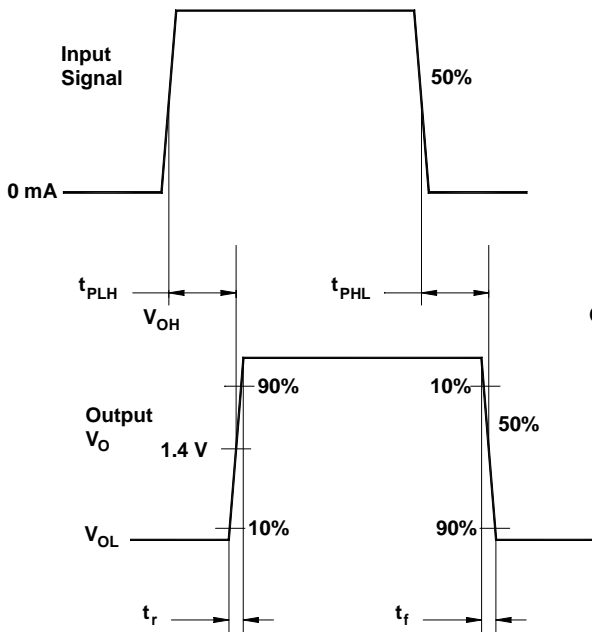
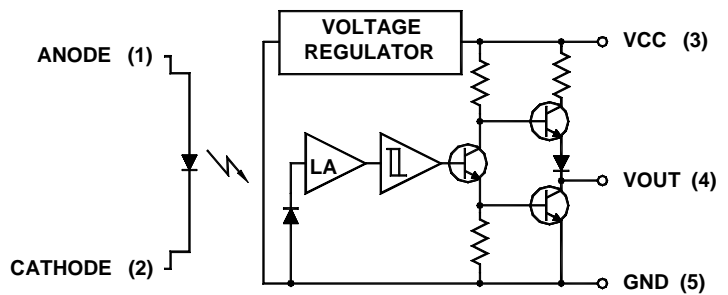

Fig. 11 Switching Test Curve for Inverters





QVE00120

OPTOLOGIC® OPTICAL INTERRUPTER SWITCH

DISCLAIMER

FAIRCHILD SEMICONDUCTOR RESERVES THE RIGHT TO MAKE CHANGES WITHOUT FURTHER NOTICE TO ANY PRODUCTS HEREIN TO IMPROVE RELIABILITY, FUNCTION OR DESIGN. FAIRCHILD DOES NOT ASSUME ANY LIABILITY ARISING OUT OF THE APPLICATION OR USE OF ANY PRODUCT OR CIRCUIT DESCRIBED HEREIN; NEITHER DOES IT CONVEY ANY LICENSE UNDER ITS PATENT RIGHTS, NOR THE RIGHTS OF OTHERS.

LIFE SUPPORT POLICY

FAIRCHILD'S PRODUCTS ARE NOT AUTHORIZED FOR USE AS CRITICAL COMPONENTS IN LIFE SUPPORT DEVICES OR SYSTEMS WITHOUT THE EXPRESS WRITTEN APPROVAL OF THE PRESIDENT OF FAIRCHILD SEMICONDUCTOR CORPORATION. As used herein:

1. Life support devices or systems are devices or systems which, (a) are intended for surgical implant into the body, or (b) support or sustain life, and (c) whose failure to perform when properly used in accordance with instructions for use provided in the labeling, can be reasonably expected to result in a significant injury of the user.
2. A critical component in any component of a life support device or system whose failure to perform can be reasonably expected to cause the failure of the life support device or system, or to affect its safety or effectiveness.