

Excellent Integrated System Limited

Stocking Distributor

Click to view price, real time Inventory, Delivery & Lifecycle Information:

[Intersil](#)
[ISL9520EVAL1Z](#)

For any questions, you can email us directly:
sales@integrated-circuit.com

ISL9520EVAL1Z Evaluation Board Setup Procedure

The ISL9520 is a highly integrated Narrow VDC regulator/battery charger controller for Li-ion/Li-ion polymer batteries. It has an SMBus interface and provides gate drive to external switching N-channel FETs that control system voltage, charge current limit, and input current limit. The ISL9520EVAL1Z evaluation board includes a USB to SMBus interface to allow users to control the ISL9520 from a personal computer.

What's Inside

The ISL9520EVAL1Z Evaluation Board Kit contains the following materials:

- Qty (1) ISL9520EVAL1Z Evaluation Board
- Qty (1) USB cable

What's Needed

The following materials are recommended to perform testing (Figure 1):

- One adjustable 25V/6A power supply
- Two adjustable electronic loads with selectable constant current mode and constant voltage mode
- One volt meter
- One 500MHz four-channel oscilloscope with voltage and current probes
- A personal computer (PC) loaded with ISL9520 control software and drivers

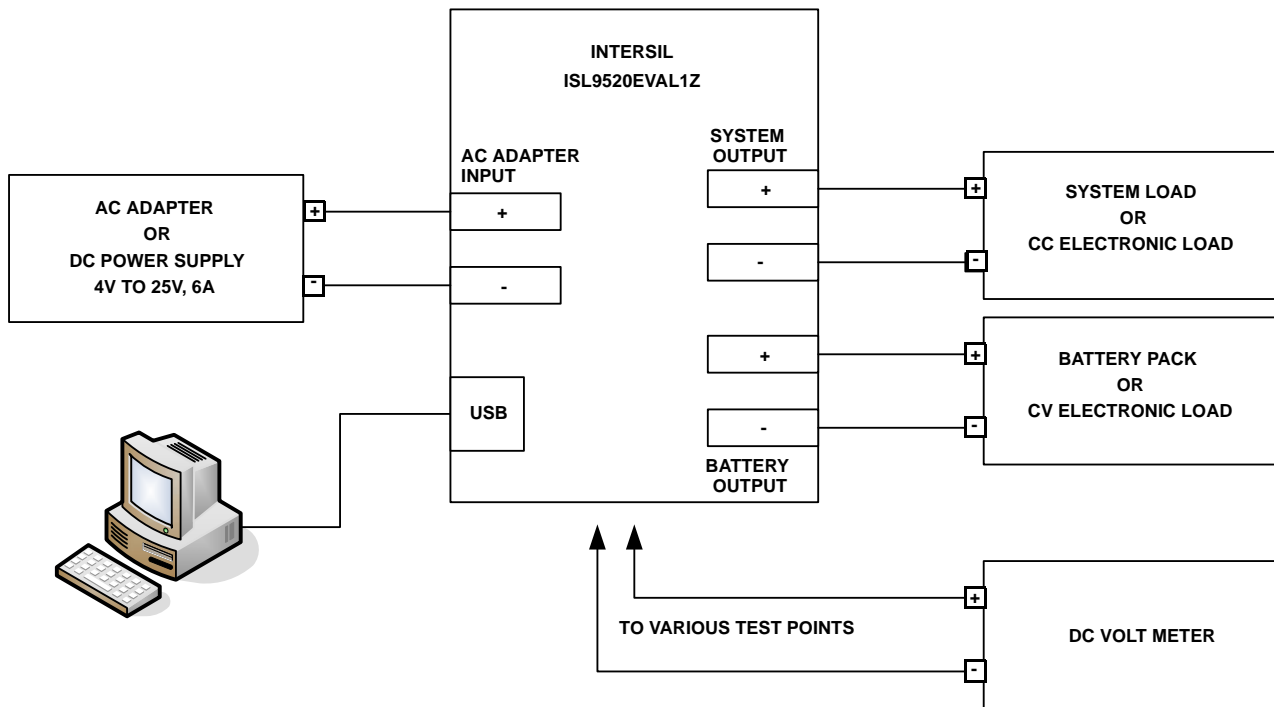

FIGURE 1. ISL9520EVAL1Z HARDWARE CONNECTION DIAGRAM

Application Note 1826

Install the Software

Download and install the ISL9520 control software by following the instructions provided in the “ISL9520 Software Installation Guide”. This document also contains troubleshooting instructions to be used in the rare event that the software does not install on the first attempt.

Run the ISL9520 Application

Plug the USB cable up, one end to the computer and the other end to the evaluation board. No other connections are required to read and write to the registers.

The ISL9520 evaluation software should be available in your computer’s **Start → All Programs** list. The “Intersil” folder will contain the program. Click the program name ISL9520 Control C1 to run the application.

Figure 2 shows the DAC Controls tab of the ISL9520 user interface. Initially, the software will indicate “FFFF” for the register values. Click the Read All icon to read the actual initial values in the registers.

Charge Current, Input Current, Max System Voltage, and Min System Voltage can be edited by clicking on the up/down arrows or by placing the cursor at the desired location and typing the correction. If the sense resistor shunts RS1 or RS2 have been changed on the board then the sense resistor values in the blue boxes should also be changed accordingly so that correct binary values are sent. The eggshell colored boxes are the digital values sent and read.

The white WRITE ALL 1/min box should be checked if a continuous test is desired, otherwise the SMBus Inactivity Time-out timer will shut down charging after 3 minutes.

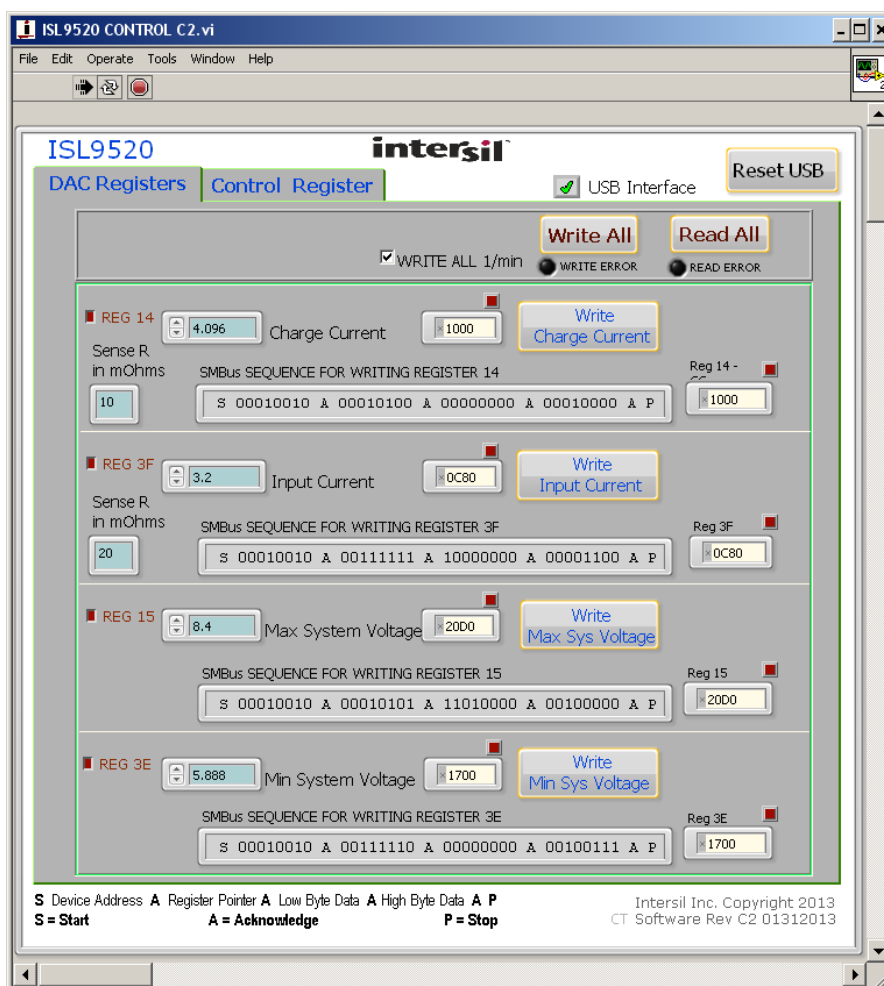

FIGURE 2. ISL9520 DAC CONTROLS TAB

Application Note 1826

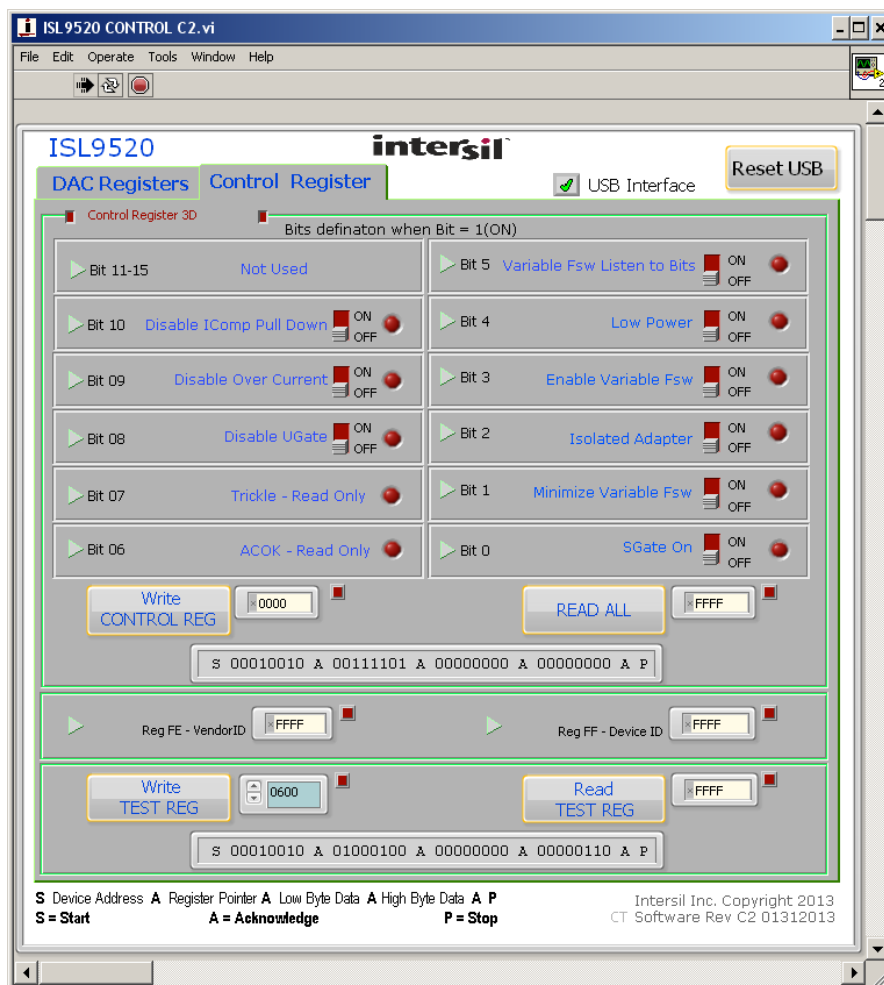

FIGURE 3. ISL9520 CONTROL REGISTER TAB

Figure 3 shows (ISL9520 Control Register tab) the control register 3D described in the data sheet and the bits that may be toggled by clicking on the individual bit switches. The configuration will be written when the Write CONTROL REG icon is clicked. The configuration is read when the READ ALL icon is clicked.

The Test Register should be written with “0600” to optimize the mode boundary transitions. To do this, place the cursor to the right of the first zero in the blue box, type a “6”, then hit the delete key once. Click on the Write test register icon, then click on the Read TEST REG icon to verify that the register has been updated.

Application Note 1826

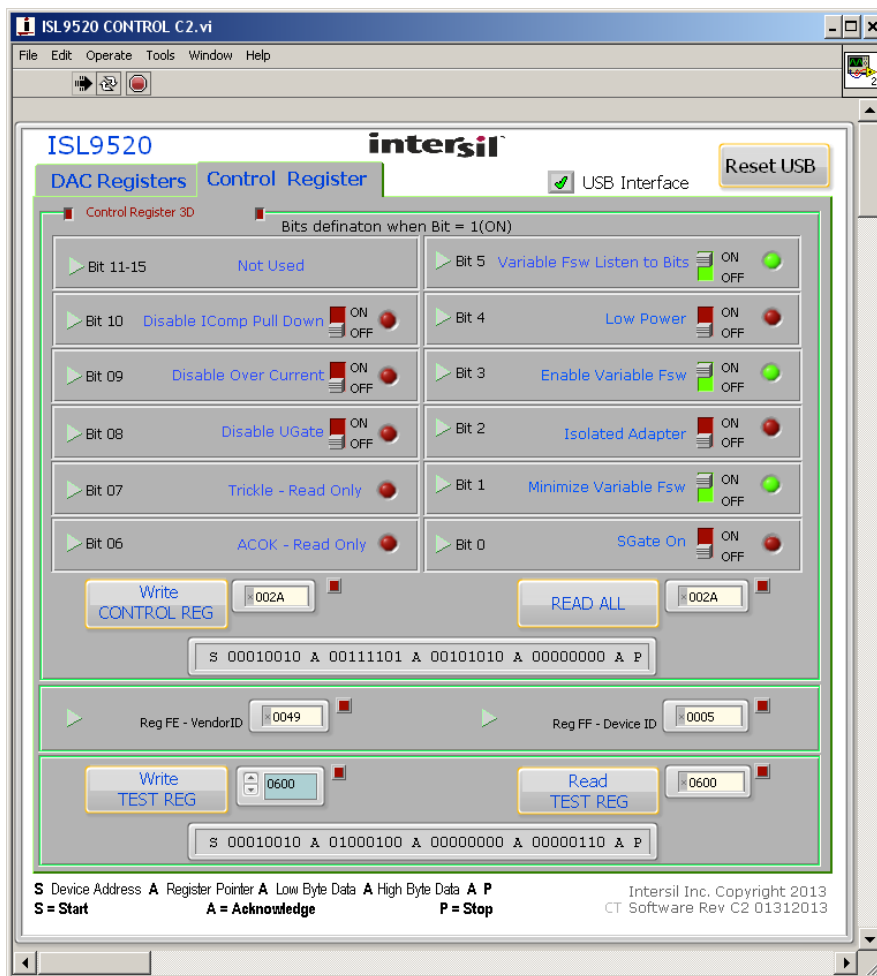

FIGURE 4. ISL9520 CONTROL REGISTER TAB AFTER EDITING TEST REGISTER

Figure 4 shows the updated Control Register tab. The VendorID (reg FE) and DeviceID (reg FF) should display 0049 and 0005 respectively.

If the power connections have not already been made, they can be made at this time. Figure 1 shows the required power connections.

ISL9520EVAL1Z Schematics

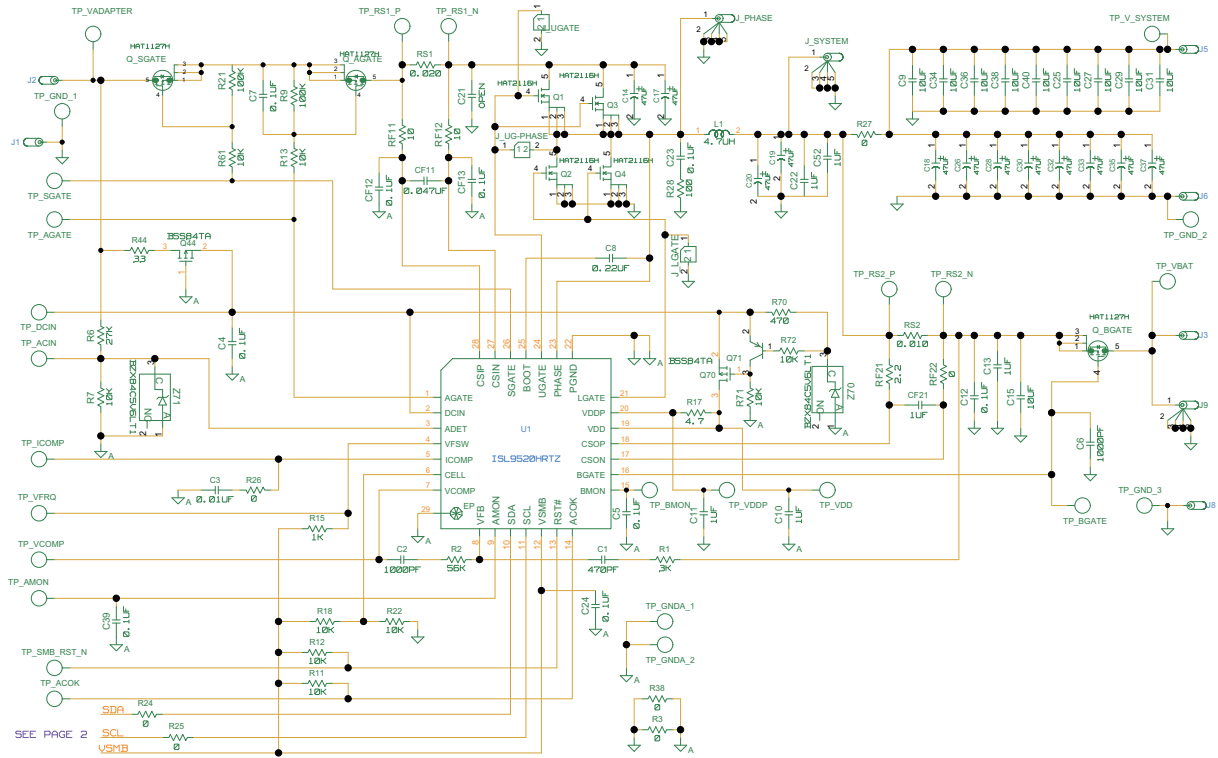

FIGURE 5. ISL9520EVAL1Z REV A SCHEMATIC

ISL9520EVAL1Z Schematics (Continued)

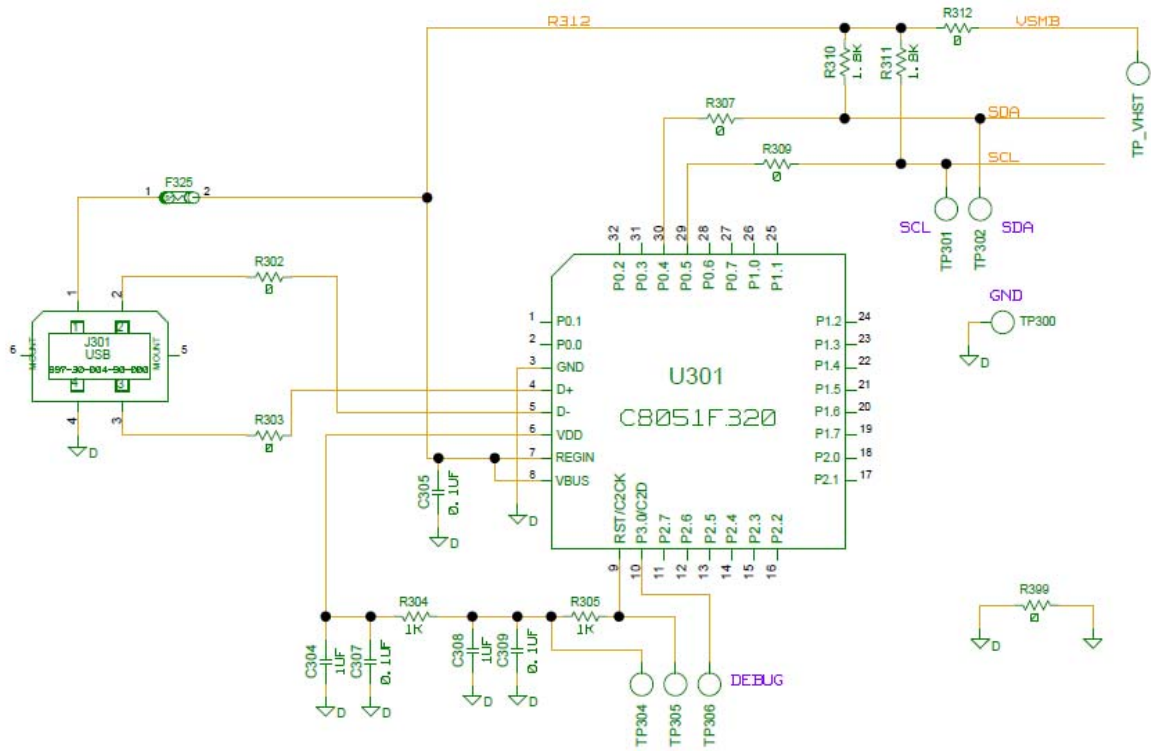

FIGURE 6. ISL9520 EVAL1Z REV A SCHEMATIC

Application Note 1826

TABLE 1. ISL9520EVAL1Z, REV A EVALUATION BOARD BILL OF MATERIALS

NO.	REFERENCE DESIGNATOR	QTY	DESCRIPTION	MANUFACTURER
1	C1	1	CAP, SMD, 0603, 470pF, 50V, 5%, X7R, ROHS	GENERIC
2	C2, C5, C6, C39	4	CAP, SMD, 0603, 1000pF, 50V, 5%, X7R, ROHS	GENERIC
3	C3	1	CAP, SMD, 0402, 0.068μF, 25V, 10%, X7R, ROHS	GENERIC
4	C10, C11, CF21, C304, C308	5	CAP, SMD, 0603, 1.0μF, 16V, 20%, X7R, ROHS	GENERIC
5	C13, C22, C52	3	CAP, SMD, 0805, 1.0μF, 25V, 10%, X5R, ROHS	GENERIC
6	C14, C17	2	CAP, SMD, 25TQC33MY, 33μF, 25V, 20%, ROHS	SANYO
7	C18, C19, C20, C26, C28, C30, C32, C33, C35, C37	10	CAP, SMD, 20TQC47MY, 47μF, 20V, 20%, ROHS	SANYO
8	C15	1	CAP, SMD, 1206, 10μF, 25V, 20%, X5R, ROHS	GENERIC
9	C4, C7, C12, C24, C39, CF12, CF13, C305, C307, C309	9	CAP, SMD, 0603, 0.1μF, 25V, 10%, X7R, ROHS	GENERIC
10	C9, C25, C27, C29, C31, C34, C36, C38, C40	9	CAP, SMD, 1812, 10μF, 25V, 20%, ROHS	
11	CF11	1	CAP, SMD, 0603, 0.047μF, 25V, 10%, X7R, ROHS	GENERIC
12	C8	1	CAP, SMD, 0603, 0.22μF, 25V, 20%, X7R, ROHS	GENERIC
13	F325	1	FUSE, SMD, MICROSMD050F	RAYCHEM-TYCO
14	J1, J6, J8	3	JACK, BANANA, BLACK, 164-6218	MOUSER
15	J2, J3, J5	3	JACK, BANANA, RED, 164-6219	MOUSER
16	JUSB	1	CONNECTOR, USB, MINI TYPE B	MIL-MAX
17	J9, J_PHASE, J_SYSTEM	3	TEST POINT, SCOPE PROBE, 131-5031-00	TEKTRONIX
18	L1	1	INDUCTOR, SMD, 4.7μH, 24A, IHLP5050CE-ER-4R7-M-01	VISHAY/DALE
19	Q_AGATE, Q_BGATE, Q_SGATE	3	MOSFET, P-CHANNEL, SMD, LPAK, 30V, 40A, HAT1127H	RENESAS
20	Q44	1	MOSFET, P-CHANNEL, SMD, SOT23, BSS84TA	FAIRCHILD
21	R1	1	RES, SMD, 0603, 3.01kΩ, 1/10W, 1%, TF, ROHS	GENERIC
22	R2	1	RES, SMD, 0603, 56.2kΩ, 1/10W, 1%, TF, ROHS	GENERIC
23	R3, R24, R25, RF22, R38, R302, R303, R307, R309, R312, R399	11	RES, SMD, 0603, 0Ω, 1/10W, TF, ROHS	GENERIC
24	RF11, RF12	2	RES, SMD, 0603, 10, 1/10W, 5%, TF, ROHS	GENERIC
25	R17	1	RES, SMD, 0603, 4.7Ω, 1/10W, 5%, TF, ROHS	GENERIC
26	R26		RES, SMD, 0603, 499Ω, 1/10W, 1%, TF, ROHS	
27	RF21	1	RES, SMD, 0603, 2.2Ω, 1/10W, 5%, TF, ROHS	GENERIC
28	R27	1	RES, SMD, 2010, 0Ω, 1/2W, 5%, TF, ROHS	GENERIC
29	R7, R9, R21	3	RES, SMD, 0603, 100kΩ, 1/10W, 1%, TF, ROHS	GENERIC
30	R15, R304, R305	3	RES, SMD, 0603, 1kΩ, 1/10W, 1%, TF, ROHS	GENERIC
31	R310, R311	2	RES, SMD, 0603, 1.8kΩ, 1/10W, 5%, TF, ROHS	GENERIC
32	R11, R12, R13, R61	4	RES, SMD, 0603, 10.0kΩ, 1/10W, 1%, TF, ROHS	GENERIC
33	R44	1	RES, SMD, 0603, 33.2Ω, 1/10W, 1%, TF, ROHS	GENERIC
34	R6	1	RES, SMD, 0603, 402kΩ, 1/10W, 1%, TF, ROHS	GENERIC
35	RS1	1	RES, SMD, 2010, 0.02Ω, 1W, 1%, LRC-LRF2010-01-R020-F	IRC
36	RS2	1	RES, SMD, 2010, 0.01Ω, 1W, 1%, LRC-LRF2010-01-R010-F	IRC

Application Note 1826

TABLE 1. ISL9520EVAL1Z, REV A EVALUATION BOARD BILL OF MATERIALS (Continued)

NO.	REFERENCE DESIGNATOR	QTY	DESCRIPTION	MANUFACTURER
37	TP_ACIN, TP_ACOK, TP_AMON, TP_VFRQ, TP_ICOMP, TP_VCOMP, TP_SMB_RST_N	7	TEST POINT, 0.063", COMPACT YELLOW, CTP5009	KEystone
38	TP_DCIN, TP_AGATE, TP_BGATE, TP_GND_1, TP_GND2, TP_GND_3, TP_RS1_N, TP_RS2_N, TP_SGATE, TP_GNDA_1, TP_GNDA_2	11	TEST POINT, 0.063", COMPACT BLACK, CTP5006	KEystone
39	TP_VDD, TP_VBAT, TP_VDDP, TP_VADAPTER, TP_V_SYSTEM	5	TEST POINT, 0.063", COMPACT RED, CTP5005	KEystone
40	TP304, TP305, TP306, TP_SCL, TP_SDA, TP_VHST, TP_GND_D, TP_RS1_P, TP_RS2_P	9	TEST POINT, 0.063", COMPACT WHITE, CTP5007	KEystone
41	U1	1	IC, BATTERY CHARGER, ISL9520, QFN50_5X7B_EP	INTERSIL
42	U301	1	IC, MICROCONTROLLER, C8051F320, 32LQFP_80	SILICON LABS

Application Note 1826

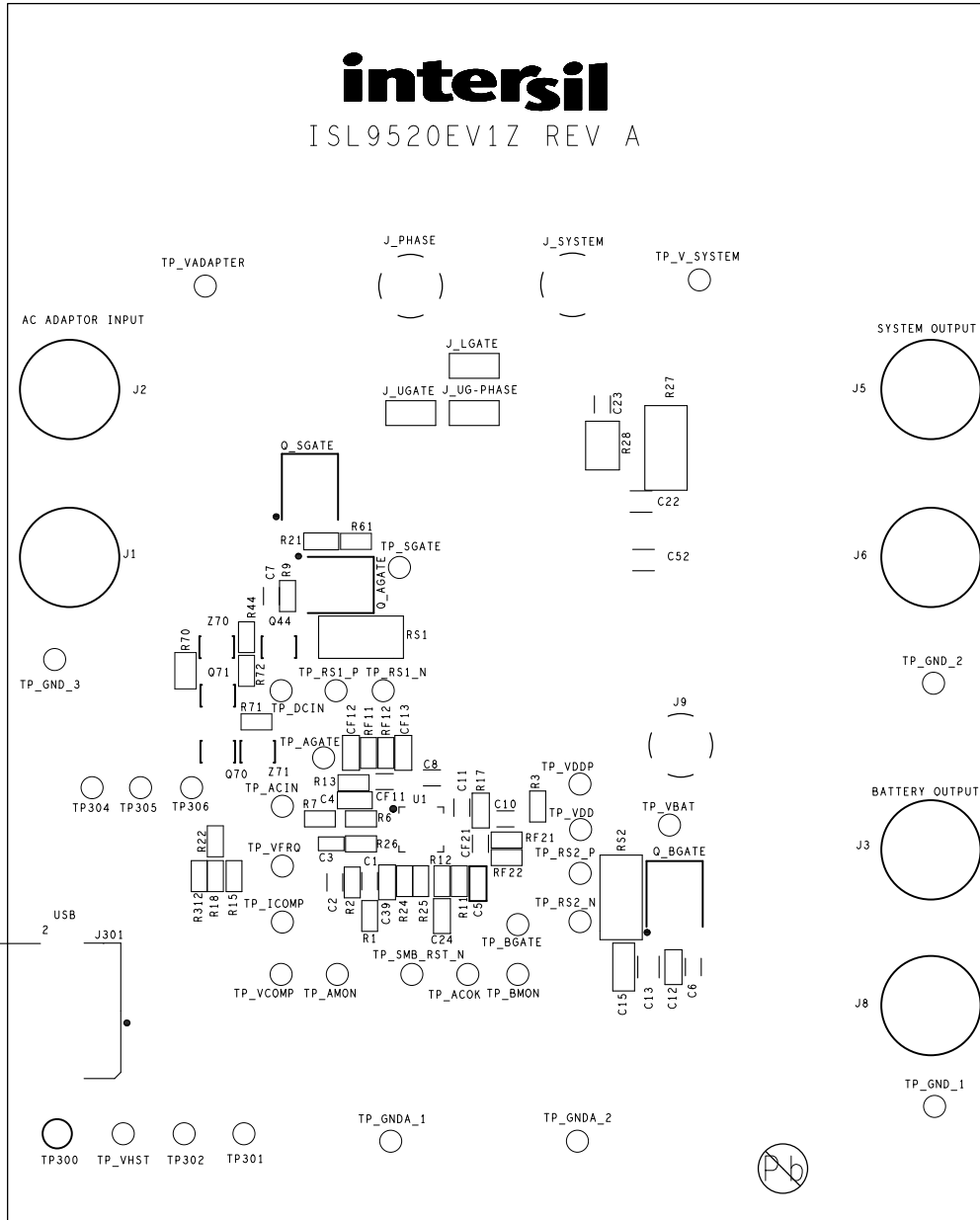

FIGURE 7. TOP SILKSCREEN

Application Note 1826

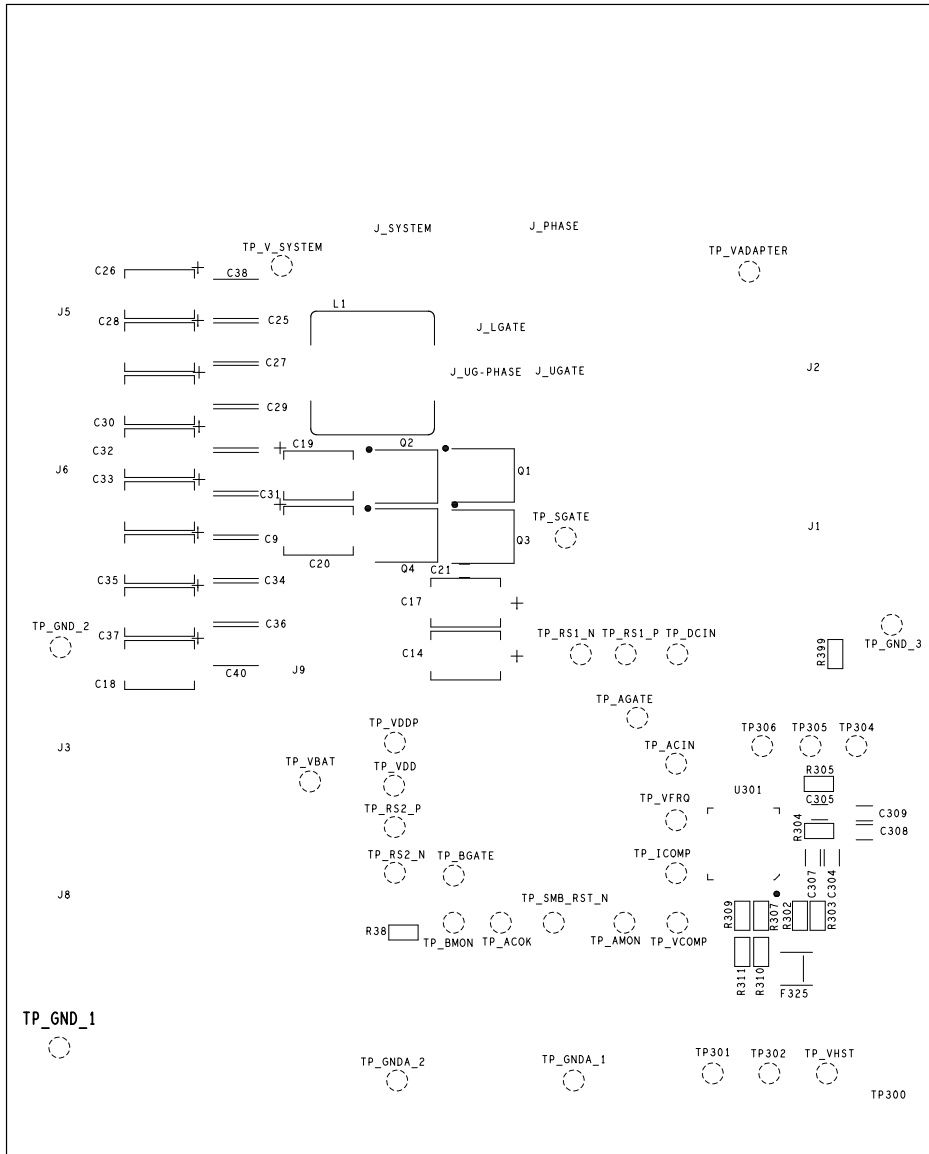

FIGURE 8. BOTTOM SILKSCREEN

Application Note 1826

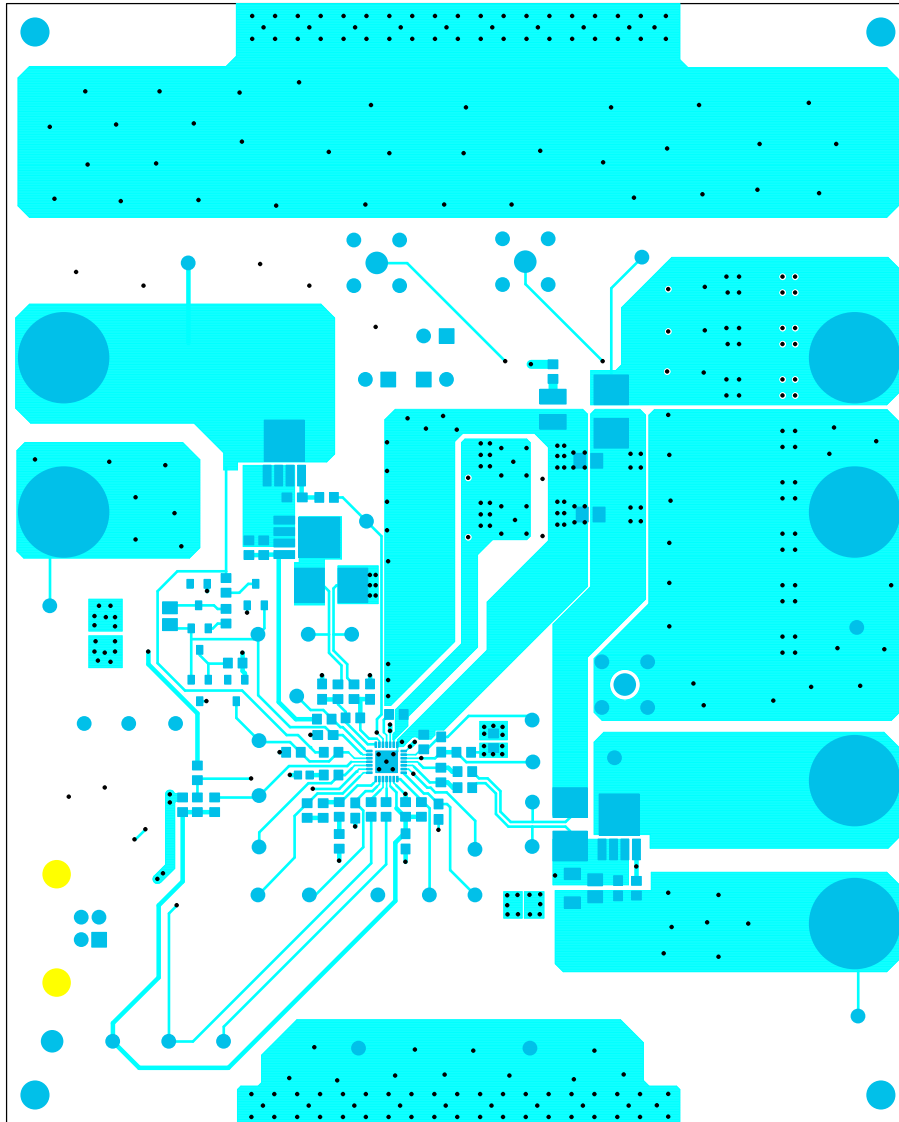

FIGURE 9. TOP LAYER COPPER

Application Note 1826

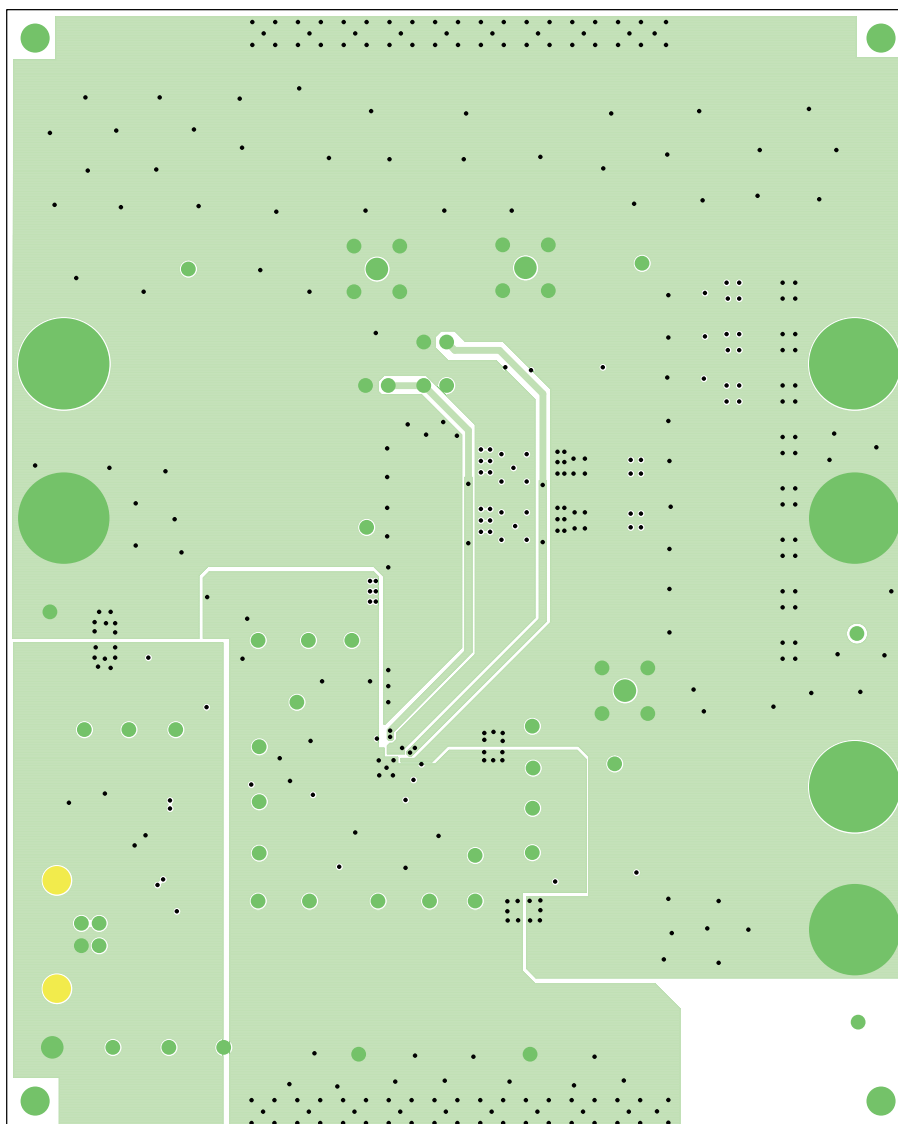

FIGURE 10. LAYER 2 COPPER

Application Note 1826

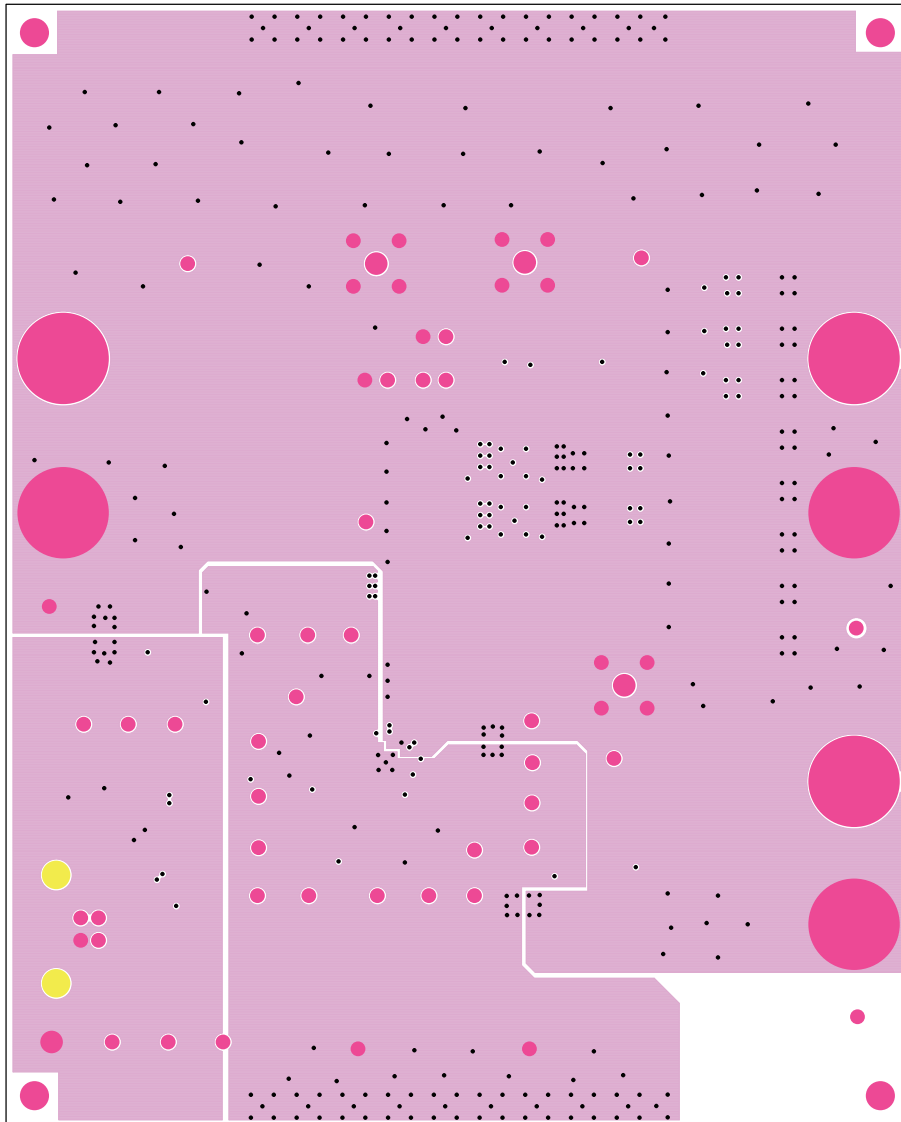

FIGURE 11. LAYER 3 COPPER

Application Note 1826

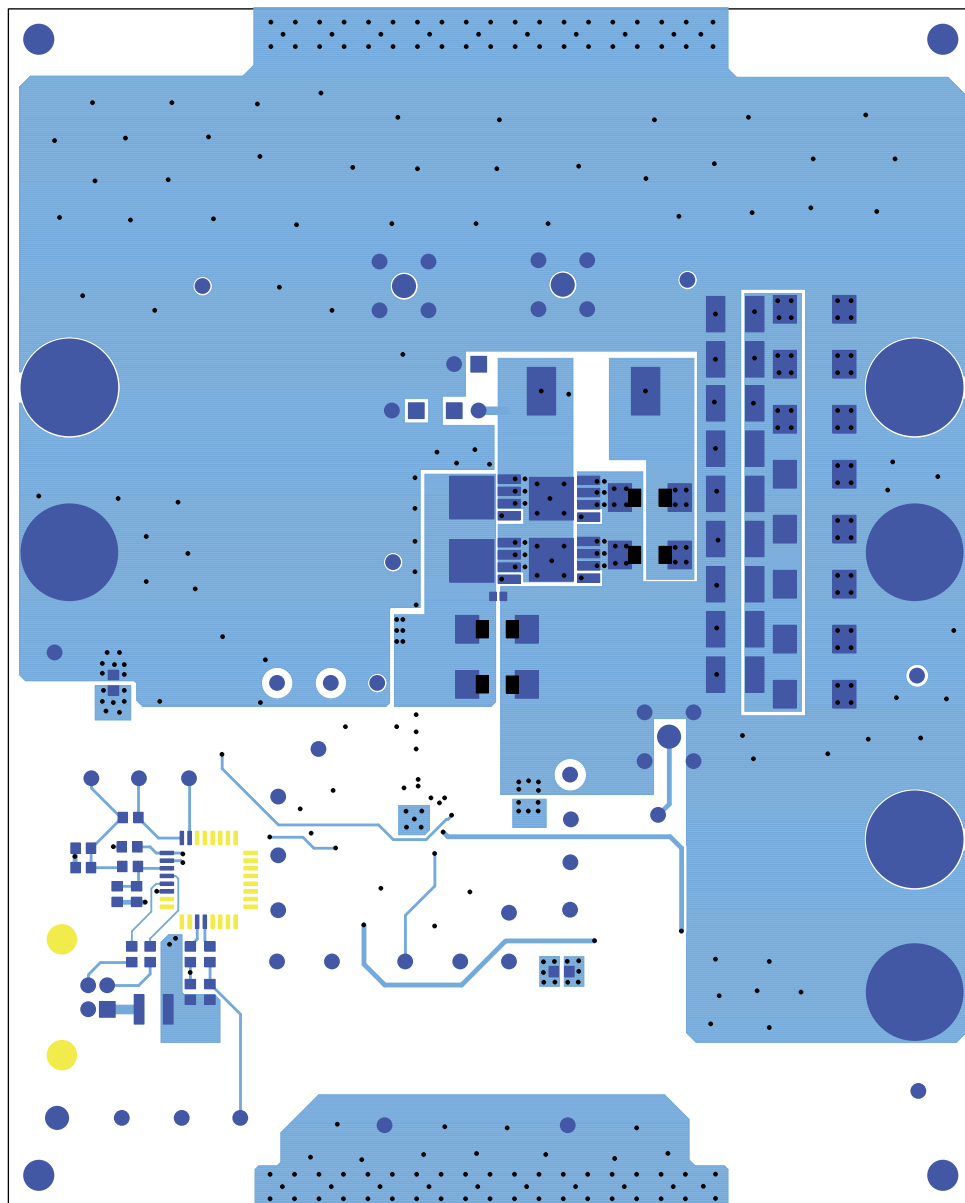

FIGURE 12. BOTTOM LAYER COPPER

Intersil Corporation reserves the right to make changes in circuit design, software and/or specifications at any time without notice. Accordingly, the reader is cautioned to verify that the Application Note or Technical Brief is current before proceeding.

For information regarding Intersil Corporation and its products, see www.intersil.com