

Excellent Integrated System Limited

Stocking Distributor

Click to view price, real time Inventory, Delivery & Lifecycle Information:

[Vishay Semiconductor/Opto Division](#)
[CNY65BEXI](#)

For any questions, you can email us directly:

sales@integrated-circuit.com



www.vishay.com

CNY65Exi

Vishay Semiconductors

Optocoupler, Phototransistor Output, ATEX Certified

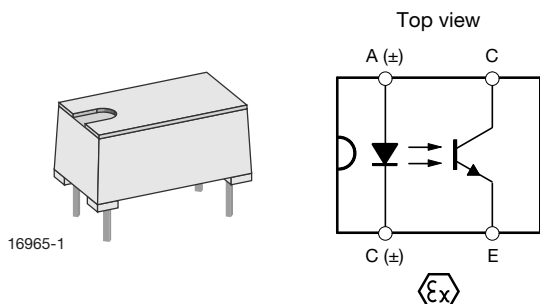

DESCRIPTION

The CNY65Exi consists of a phototransistor optically coupled to an infrared-emitting diode in a 4 pin plastic package. The components are mounted opposite one another, with a distance between input and output of > 3.0 mm; meeting the highest of safety requirements.

The CNY65Exi is ATEX certificated for explosive atmospheres according to the European Guide line 94/9/EG.

AGENCY APPROVALS

- ATEX Ex : PTB 03 ATEX 2033 U
 EN 60079-0:2012
 EN 60079-11:2012
 EN 60079-26:2007

FEATURES

- ATEX certificate: PTB 03 ATEX 2033 U
www.vishay.com/doc?285361
- Suitable for intrinsic safe circuits for gas and dust
- Gas safety provision: II (1) G (EX ia) IIC
- Dust safety provision: II (1) D (EX ia) III C
- Conforms to EN60079-0:2012
- Qualified for continuously, longterm, or frequently dangerous explosive environments, zone 0
- Isolation voltage (V_{ISO}) of 11 600 V_{peak} for 1 minute
- Distance from emitter to detector through insulation ≥ 3 mm
- CTR from 50 % to 300 %
- Very low coupling capacity (C_K)
 - 0.3 pF superior noise immunity between input and output pins
- Material categorization: for definitions of compliance please see www.vishay.com/doc?99912



RoHS
COMPLIANT

APPLICATIONS

- Electronics used in potentially explosive gas and dust environments
 - Safety related process automation and instrumentation
 - Natural gas metering and flow measurement
 - Power and motor switching
 - Power supplies, metering, and data acquisition
 - Lighting and signaling
 - Petrol and grain transport and storage

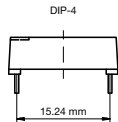
ORDERING INFORMATION		
<div style="display: flex; justify-content: space-around; align-items: center;"> <div style="border: 1px solid black; padding: 2px 5px;">C</div> <div style="border: 1px solid black; padding: 2px 5px;">N</div> <div style="border: 1px solid black; padding: 2px 5px;">Y</div> <div style="border: 1px solid black; padding: 2px 5px;">6</div> <div style="border: 1px solid black; padding: 2px 5px;">5</div> <div style="border: 1px solid black; padding: 2px 5px;">X</div> <div style="border: 1px solid black; padding: 2px 5px;">E</div> <div style="border: 1px solid black; padding: 2px 5px;">x</div> <div style="border: 1px solid black; padding: 2px 5px;">i</div> </div> <p style="text-align: center;">PART NUMBER CTR BIN PACKAGE OPTION</p>		
AGENCY CERTIFIED/PACKAGE	CTR (%)	
ATEX	50 to 300	100 to 200
DIP-4, HV, high isolation distance	CNY65Exi	CNY65BExi



ABSOLUTE MAXIMUM RATINGS ($T_{amb} = 25\text{ }^{\circ}\text{C}$, unless otherwise specified)				
PARAMETER	TEST CONDITION	SYMBOL	VALUE	UNIT
INPUT				
Reverse voltage		V_R	5	V
Forward current		I_F	75	mA
Forward surge current	$t_p \leq 10\text{ }\mu\text{s}$	I_{FSM}	1.5	A
Power dissipation		P_{diss}	120	mW
Junction temperature		T_j	100	$^{\circ}\text{C}$
OUTPUT				
Collector emitter voltage		V_{CEO}	32	V
Emitter collector voltage		V_{ECO}	7	V
Collector current		I_C	50	mA
Collector peak current	$t_p/T = 0.5, t_p \leq 10\text{ ms}$	I_{CM}	100	mA
Power dissipation		P_{diss}	130	mW
Junction temperature		T_j	100	$^{\circ}\text{C}$
COUPLER				
DC isolation test voltage	$t = 1\text{ min}$	V_{ISO}	11.6	kV
Total power dissipation		P_{tot}	250	mW
Ambient temperature range		T_{amb}	-55 to +85	$^{\circ}\text{C}$
Storage temperature range		T_{stg}	-55 to +100	$^{\circ}\text{C}$
Soldering temperature	2 mm from case, $t \leq 10\text{ s}$	T_{slid}	260	$^{\circ}\text{C}$

Note

- Stresses in excess of the absolute Maximum Ratings can cause permanent damage to the device. Functional operation of the device is not implied at these or any other conditions in excess of those given in the operational sections of this document. Exposure to absolute Maximum Rating for extended periods of the time can adversely affect reliability.

ELECTRICAL CHARACTERISTICS ($T_{amb} = 25\text{ }^{\circ}\text{C}$, unless otherwise specified)						
PARAMETER	TEST CONDITION	SYMBOL	MIN.	TYP.	MAX.	UNIT
INPUT						
Forward voltage	$I_F = 50\text{ mA}$	V_F		1.25	1.6	V
OUTPUT						
Collector emitter voltage	$I_C = 1\text{ mA}$	V_{CEO}	32			V
Emitter collector voltage	$I_E = 100\text{ }\mu\text{A}$	V_{ECO}	7			V
Collector dark current	$V_{CE} = 20\text{ V}, I_f = 0, E = 0$	I_{CEO}			200	nA
COUPLER						
DC isolation test voltage	$t = 1\text{ min}$	$V_{ISO}^{(1)}$	11.6			kV
Isolation resistance	$V_{IO} = 1\text{ kV}$, 40 % relative humidity	$R_{IO}^{(1)}$		10^{12}		Ω
Collector saturation voltage	$I_F = 10\text{ mA}, I_C = 1\text{ mA}$	V_{CEsat}			0.3	V
Cut-off frequency	$V_{CE} = 5\text{ V}, I_F = 10\text{ mA}$, $R_L = 100\text{ }\Omega$	f_c	110			kHz
Coupling capacitance	$f = 1\text{ MHz}$	C_k		0.3		pF

Notes

- Minimum and maximum values are testing requirements. Typical values are characteristics of the device and are the result of engineering evaluation. Typical values are for information only and are not part of the testing requirements.
- (1) Related to standard climate 23/50 DIN 50014.

CURRENT TRANSFER RATIO ($T_{amb} = 25\text{ }^{\circ}\text{C}$, unless otherwise specified)							
PARAMETER	TEST CONDITION	PART	SYMBOL	MIN.	TYP.	MAX.	UNIT
I_C/I_F	$V_{CE} = 5\text{ V}, I_F = 10\text{ mA}$	CNY65Exi	CTR	50	100	300	%
		CNY65BEXi	CTR	100		200	%

SWITCHING CHARACTERISTICS ($T_{amb} = 25\text{ }^{\circ}\text{C}$, unless otherwise specified)						
PARAMETER	TEST CONDITION	SYMBOL	MIN.	TYP.	MAX.	UNIT
Delay time	$V_S = 5\text{ V}$, $I_C = 5\text{ mA}$, $R_L = 100\text{ }\Omega$, (see figure 1)	t_d		2.6		μs
Rise time	$V_S = 5\text{ V}$, $I_C = 5\text{ mA}$, $R_L = 100\text{ }\Omega$, (see figure 1)	t_r		2.4		μs
Fall time	$V_S = 5\text{ V}$, $I_C = 5\text{ mA}$, $R_L = 100\text{ }\Omega$, (see figure 1)	t_f		2.4		μs
Storage time	$V_S = 5\text{ V}$, $I_C = 5\text{ mA}$, $R_L = 100\text{ }\Omega$, (see figure 1)	t_s		0.3		μs
Turn-on time	$V_S = 5\text{ V}$, $I_C = 5\text{ mA}$, $R_L = 100\text{ }\Omega$, (see figure 1)	t_{on}		5		μs
Turn-off time	$V_S = 5\text{ V}$, $I_C = 5\text{ mA}$, $R_L = 100\text{ }\Omega$, (see figure 1)	t_{off}		3		μs
Turn-on time	$V_S = 5\text{ V}$, $I_F = 10\text{ mA}$, $R_L = 1\text{ k}\Omega$, (see figure 2)	t_{on}		25		μs
Turn-off time	$V_S = 5\text{ V}$, $I_F = 10\text{ mA}$, $R_L = 1\text{ k}\Omega$, (see figure 2)	t_{off}		42.5		μs

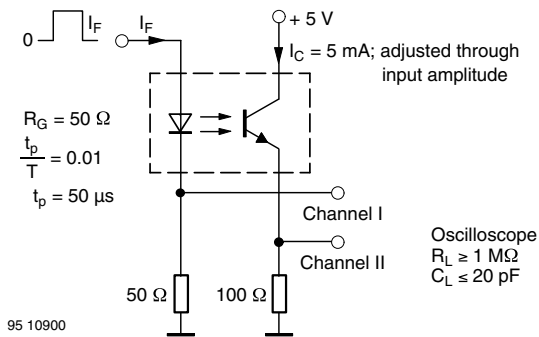

Fig. 1 - Test Circuit, Non-Saturated Operation

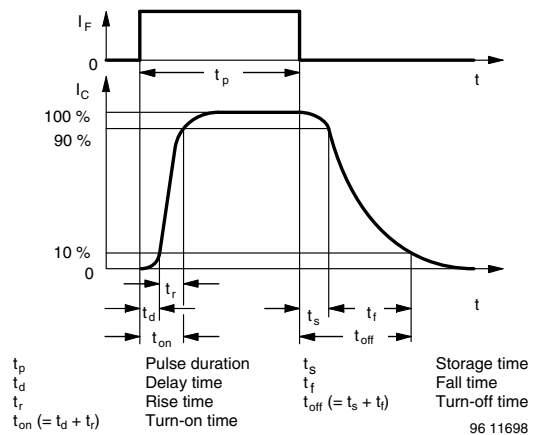

Fig. 3 - Switching Times

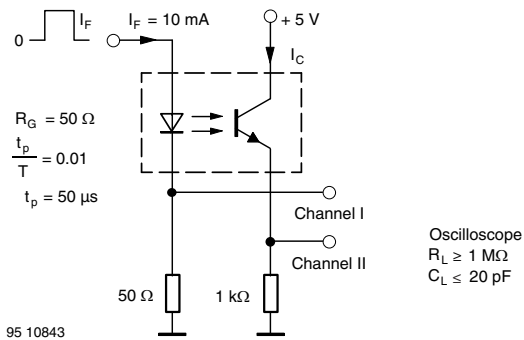

Fig. 2 - Test Circuit, Saturated Operation



www.vishay.com

CNY65Exi

Vishay Semiconductors

TYPICAL CHARACTERISTICS ($T_{amb} = 25\text{ }^{\circ}\text{C}$, unless otherwise specified)

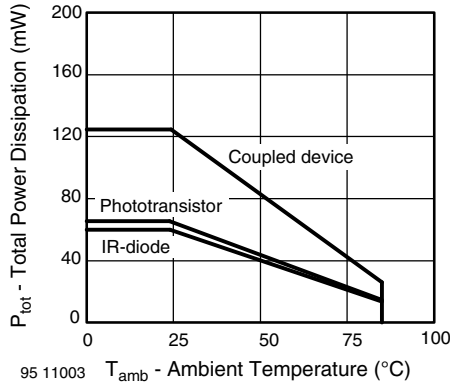

Fig. 4 - Total Power Dissipation vs. Ambient Temperature

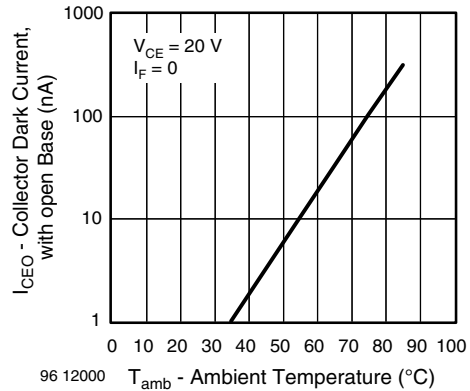

Fig. 7 - Collector Dark Current vs. Ambient Temperature

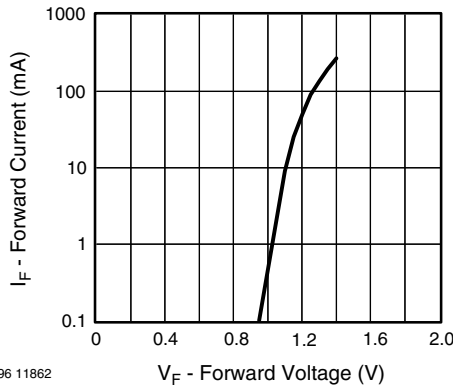

Fig. 5 - Forward Current vs. Forward Voltage

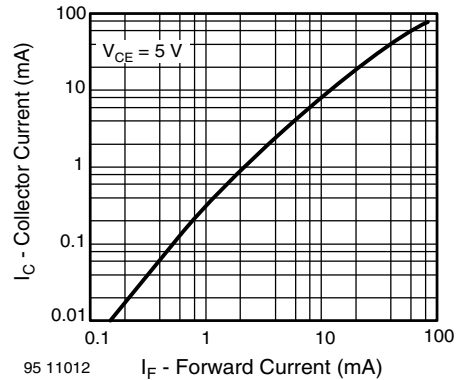

Fig. 8 - Collector Current vs. Forward Current

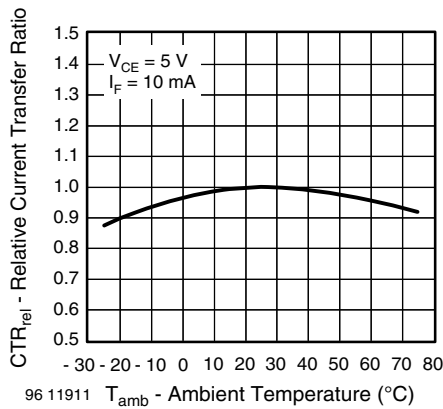

Fig. 6 - Relative Current Transfer Ratio vs. Ambient Temperature

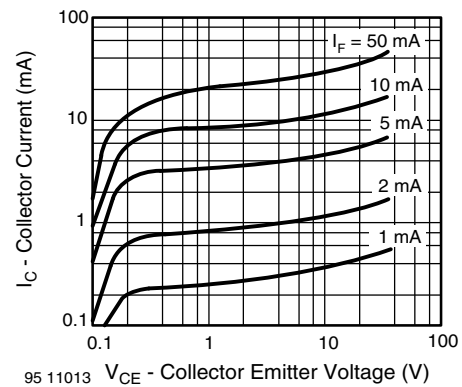

Fig. 9 - Collector Current vs. Collector Emitter Voltage



www.vishay.com

CNY65Exi

Vishay Semiconductors

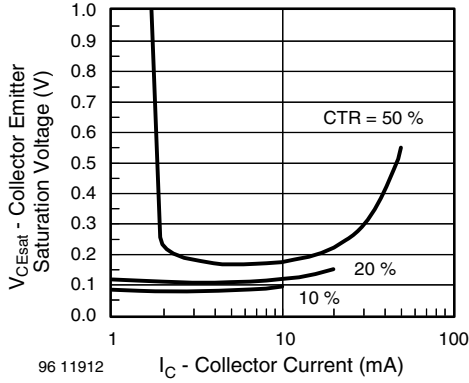

Fig. 10 - Collector Emitter Saturation Voltage vs. Collector Current

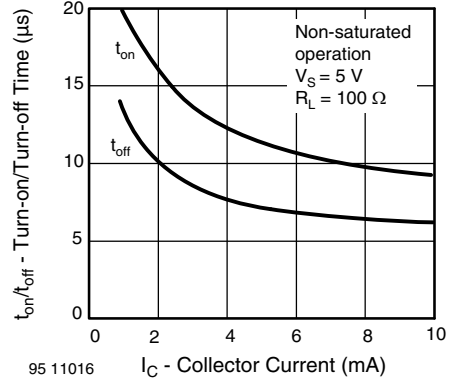

Fig. 13 - Turn-on/Turn-off Time vs. Collector Current

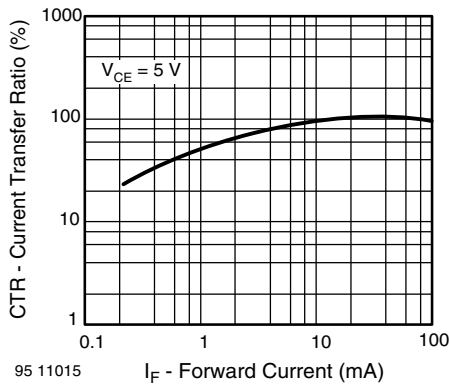

Fig. 11 - Current Transfer Ratio vs. Forward Current

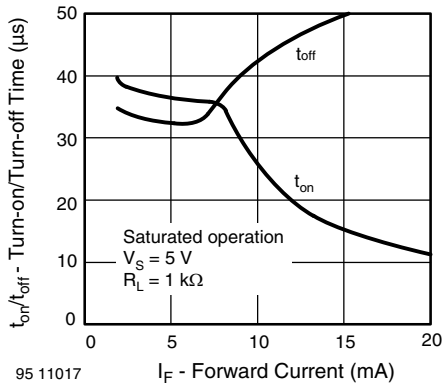

Fig. 12 - Turn-on/Turn-off Time vs. Forward Current



www.vishay.com

CNY65Exi

Vishay Semiconductors

PACKAGE DIMENSIONS in millimeters

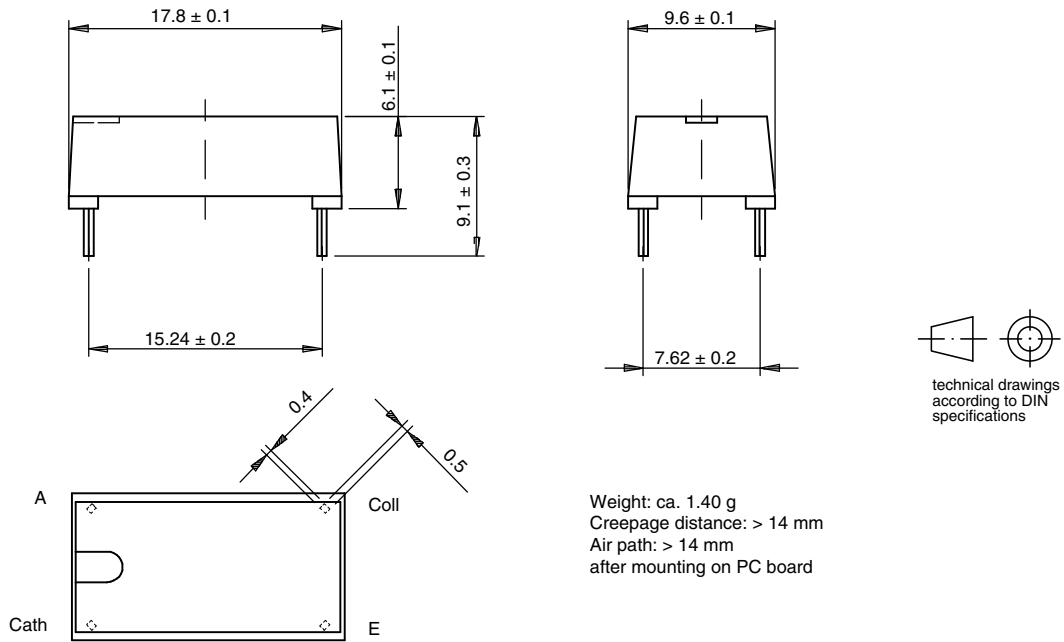

technical drawings according to DIN specifications

Weight: ca. 1.40 g
 Creepage distance: > 14 mm
 Air path: > 14 mm
 after mounting on PC board

Drawing-No.: 6.544-5036.01-1
 Issue: 2; 10.11.98
 14763

PACKAGE MARKING (example of CNY65BEXi)

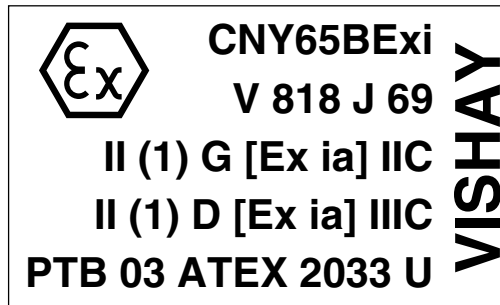

HANDLING AND STORAGE CONDITIONS

ESD level: HBM class 2



Disclaimer

ALL PRODUCT, PRODUCT SPECIFICATIONS AND DATA ARE SUBJECT TO CHANGE WITHOUT NOTICE TO IMPROVE RELIABILITY, FUNCTION OR DESIGN OR OTHERWISE.

Vishay Intertechnology, Inc., its affiliates, agents, and employees, and all persons acting on its or their behalf (collectively, "Vishay"), disclaim any and all liability for any errors, inaccuracies or incompleteness contained in any datasheet or in any other disclosure relating to any product.

Vishay makes no warranty, representation or guarantee regarding the suitability of the products for any particular purpose or the continuing production of any product. To the maximum extent permitted by applicable law, Vishay disclaims (i) any and all liability arising out of the application or use of any product, (ii) any and all liability, including without limitation special, consequential or incidental damages, and (iii) any and all implied warranties, including warranties of fitness for particular purpose, non-infringement and merchantability.

Statements regarding the suitability of products for certain types of applications are based on Vishay's knowledge of typical requirements that are often placed on Vishay products in generic applications. Such statements are not binding statements about the suitability of products for a particular application. It is the customer's responsibility to validate that a particular product with the properties described in the product specification is suitable for use in a particular application. Parameters provided in datasheets and / or specifications may vary in different applications and performance may vary over time. All operating parameters, including typical parameters, must be validated for each customer application by the customer's technical experts. Product specifications do not expand or otherwise modify Vishay's terms and conditions of purchase, including but not limited to the warranty expressed therein.

Except as expressly indicated in writing, Vishay products are not designed for use in medical, life-saving, or life-sustaining applications or for any other application in which the failure of the Vishay product could result in personal injury or death. Customers using or selling Vishay products not expressly indicated for use in such applications do so at their own risk. Please contact authorized Vishay personnel to obtain written terms and conditions regarding products designed for such applications.

No license, express or implied, by estoppel or otherwise, to any intellectual property rights is granted by this document or by any conduct of Vishay. Product names and markings noted herein may be trademarks of their respective owners.