

Excellent Integrated System Limited

Stocking Distributor

Click to view price, real time Inventory, Delivery & Lifecycle Information:

[NorComp](#)
[170-702-170-000](#)

For any questions, you can email us directly:
sales@integrated-circuit.com

PROPER USE GUIDELINES

Cumulative Trauma Disorder can result from the prolonged use of manually powered hand tools. NorComp hand tools are intended for the occasional use and low volume applications. NorComp offers a wide selection of powered application equipment for extended use, production operations.

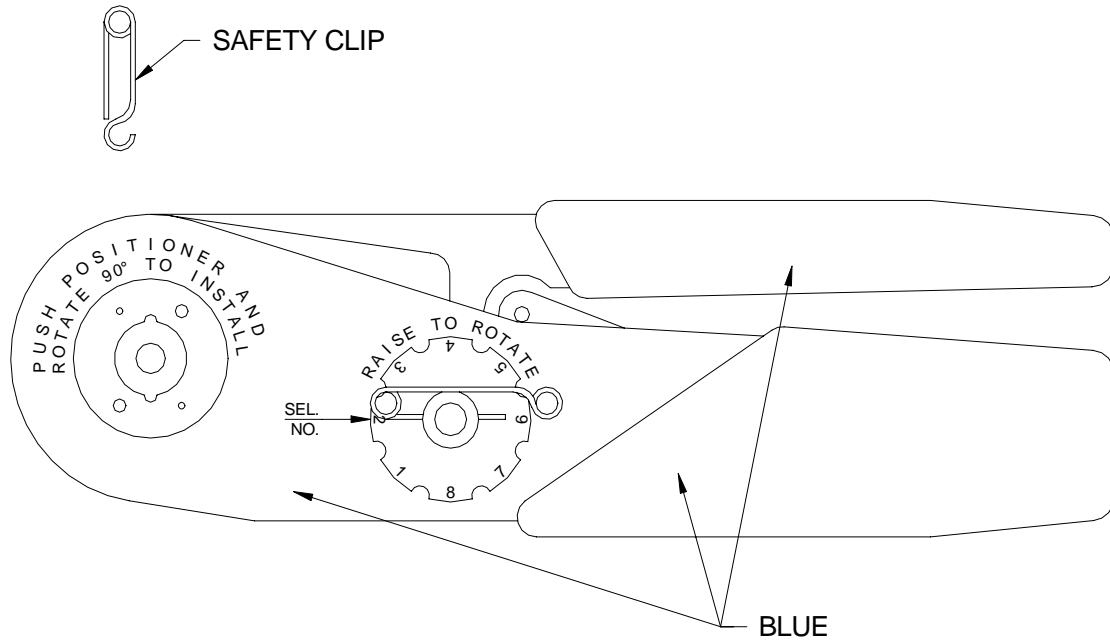

Figure 1

1. GENERAL INFORMATION

NorComp 170-702-170-000 Hand Tool Assembly refers to basic hand tool with positioner (K1290). Hand Tool Assembly is used to crimp NorComp contacts, part numbers:

- | | |
|-----------------|-----------------|
| 170-201-170L002 | 170-202-170L002 |
| 170-201-170L003 | 170-202-170L003 |

Wire crimp range 26 AWG to 20 AWG.
 Recommended strip length: 0.150in. [3.81mm]

The tool has a double action ratchet. The tool cannot be opened without completing the cycle.

- d. Install safety clip into positioner guide.
- e. Wire size and corresponding selector number are shown on data plate.

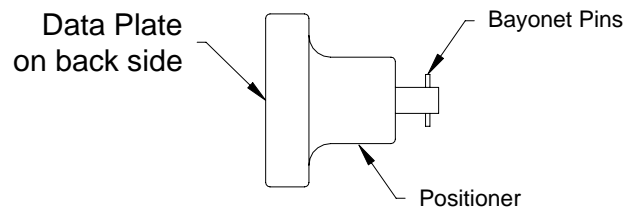

Figure 2

2. TOOL PREPARATION

- a. The tool must be in the open position.
- b. Remove safety clip from positioner guide.
- c. Insert positioner into positioner guide and turn 90 degrees until bayonet pins lock.

- f. With tool still in open position, raise, and rotate selector knob until number indicated on data plate for wire size to be crimped is in line with selector number arrow.



3. CRIMPING INSTRUCTIONS

- a. Insert contact and prepared wire into indenter opening from side opposite the positioner.
- b. Squeeze handles together until ratchet releases. Handle will return to the open position. Remove crimped contact and wire.

4. CRIMP TEST

Test each crimp using Table 1.

WIRE SIZE Max AWG	PULL TEST lb.
20	12
22	10
24	8
26	6

Table 1

5. REMOVING POSITIONER

Remove safety clip and reverse procedure described in step 2.d. above.

6. MAINTENANCE

There is virtually no maintenance required. However, it is a good practice to keep indenter tips free of residual and other debris. A small wire brush may be used for this purpose.

We strongly recommend that you:

- DO NOT immerse tool in cleaning solution
- DO NOT spray oil into tool to lubricate
- DO NOT attempt to disassemble tool to make repairs

This is a precision crimp tool and should be handled with care.

7. VISUAL INSPECTION

The crimping tool should be inspected on a regular basis to ensure that it has not become worn or damaged. If damage or abnormal wear is evident, the tool must be replaced.