

Excellent Integrated System Limited

Stocking Distributor

Click to view price, real time Inventory, Delivery & Lifecycle Information:

[Artesyn Embedded Technologies](#)
[BXB150-24S3V3FLT](#)

For any questions, you can email us directly:

sales@integrated-circuit.com

BXB150 Series

Single output



DC/DC CONVERTERS | 100-150W Wide Input DC/DC Converters

1

- Industry standard footprint
- MTBF >1.4 million hours (Bellcore 332)
- Input voltage to ETS300-132-2
- Adjustable output voltage
- No minimum load required
- Separate case ground pin
- 2:1 input range for battery powered applications
- Undervoltage lockout (UVLO)
- UL, VDE and CSA safety approvals



2 YEAR WARRANTY

All specifications are typical at nominal input, full load at 25°C unless otherwise stated

SPECIFICATIONS

OUTPUT SPECIFICATIONS

Voltage adjustability	60% to 110%	
Set point accuracy	±1.0%	
Line regulation	Low line to high line	±0.05%
Load regulation	Full load to min. load	±0.10%
Minimum load	0%	
Overshoot	At turn-on and turn-off	None
Undershoot	None	
Ripple and noise (5Hz to 20MHz) (See Note 1)	3.3V and 5V	75mV pk-pk, 20mV rms
	12V and 15V	100mV pk-pk, 30mV rms
Temperature coefficient	±0.01%/°C	
Transient response (See Note 2)	±2.0% max. deviation 170µs recovery to within ±1.0%	
Remote sense	0.5VDC transmission line drop compensation	

INPUT SPECIFICATIONS

Input voltage range	24Vin nominal	18 to 36VDC
	48Vin nominal	36 to 75VDC
Input current	No load	130mA max.
	Remote OFF	20mA max.
Input current (max.) (See Note 4)	24Vin	9.0A max. @ Io max. and Vin = 0 to 75V
	48Vin	6.5A max. @ Io max. and Vin = 0 to 75V
Input reflected ripple (See Note 6)	5mA pk-pk	
Active low remote ON/OFF	(See Note 7)	
Logic compatibility	Open collector ref to -input	
ON	1.2VDC max.	
OFF	Open circuit	

INPUT SPECIFICATIONS (continued)

Undervoltage lockout	24Vin: power up	17V
	24Vin: power down	16.3V
	48Vin: power up	34V
	48Vin: power down	32.5V
Start-up time (See Note 8)	Power up	20ms
	Remote ON/OFF	20ms

EMC CHARACTERISTICS

Conducted emissions (See Note 3)	Bellcore 1089	Level A
	FCC part 15	Level A
	EN55022, CISPR22	Level A

GENERAL SPECIFICATIONS

Efficiency	See table	
Isolation voltage	Input/case	1500VDC
	Input/output	1500VDC
	Output/case	1500VDC
Switching frequency	Fixed	500kHz typ.
Approvals and standards (See Note 5)	VDE0805, EN60950, IEC950 UL1950, CSA C22.2 No. 950	
Case material	Aluminum baseplate with plastic case	
Material flammability	UL94V-0	
Weight	110g (3.88oz)	
MTBF	Bellcore 332	1,400,000 hours
	MIL-HDBK-217F @ 40°C, 100% FL	580,000 hours min.

ENVIRONMENTAL SPECIFICATIONS

Thermal performance	Operating case temp.	-40°C to +100°C
	Non-operating	-55°C to +125°C
Altitude	Operating	10,000 feet max.
	Non-operating	40,000 feet max.
Vibration	5Hz to 500Hz	2.4G rms (approx.)

BXB150 Series

Single output

DC/DC CONVERTERS | 100-150W Wide Input DC/DC Converters

2

For the most current data and application support visit www.artesyn.com/powergroup/products.htm

OUTPUT POWER (MAX.)	INPUT VOLTAGE	OVP	OUTPUT VOLTAGE	OUTPUT CURRENT (MIN.)	OUTPUT CURRENT (MAX.)	EFFICIENCY (TYP.)	REGULATION		MODEL NUMBER (7)
							LINE	LOAD	
100W	18-36VDC	4.3VDC	3.3V	0A	30A	77%	±0.05%	±0.1%	BXB150-24S3V3FLT
100W	36-75VDC	4.3VDC	3.3V	0A	30A	79%	±0.05%	±0.1%	BXB150-48S3V3FLT
150W	36-75VDC	6.5VDC	5V	0A	30A	84%	±0.05%	±0.1%	BXB150-48S05FLT
150W	36-75VDC	14.5VDC	12V	0A	12.5A	84%	±0.05%	±0.1%	BXB150-48S12FLT
150W	36-75VDC	17.5VDC	15V	0A	10A	88%	±0.05%	±0.1%	BXB150-48S15FLT

Notes

- Measured with 10µF tantalum capacitor and 1µF ceramic capacitor across output.
- di/dt = 0.1A/1µs, Vin = 48VDC, Tc = 25°C, load change = 0.5 lo max. to 0.75 lo max. and 0.75 lo max. to 0.5 lo max.
- Units should be characterised within systems. External components required.
- Input fusing is recommended based on surge current and maximum input current.
- This product is only for inclusion by professional installers within other equipment and must not be operated as a stand alone product.
- Simulated source impedance of 12µH. 12µH inductor in series with +Vin.
- Active high remote on/off option is available (standard product is active low), designate with the suffix 'FHT' e.g. **BXB150-48S05FHT**. Consult factory for further details and options.
- Start-up into resistive load.

PROTECTION

Short circuit protection	Continuous, automatic recovery
Overvoltage protection	Non-latching
Undervoltage protection	Non-latching
Thermal protection	110°C baseplate, automatic recovery

TELECOM SPECIFICATION

Central office interface A	ETS300-132-2
----------------------------	--------------

EXTERNAL OUTPUT TRIMMING

Output can be externally trimmed by using the method shown.

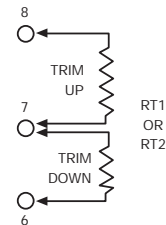

International Safety Standard Approvals

- VDE0805/EN60950/IEC950 File No. 10401-3336-1095
- UL1950 File No. E136005
- CSA C22.2 No. 950 File No. LR41062C

PIN CONNECTIONS	
PIN NUMBER	FUNCTION
1	+ Vin
2	Remote ON/OFF
3	Case
4	- Vin
5	- Vout
6	- Sense
7	Trim
8	+ Sense
9	+ Vout

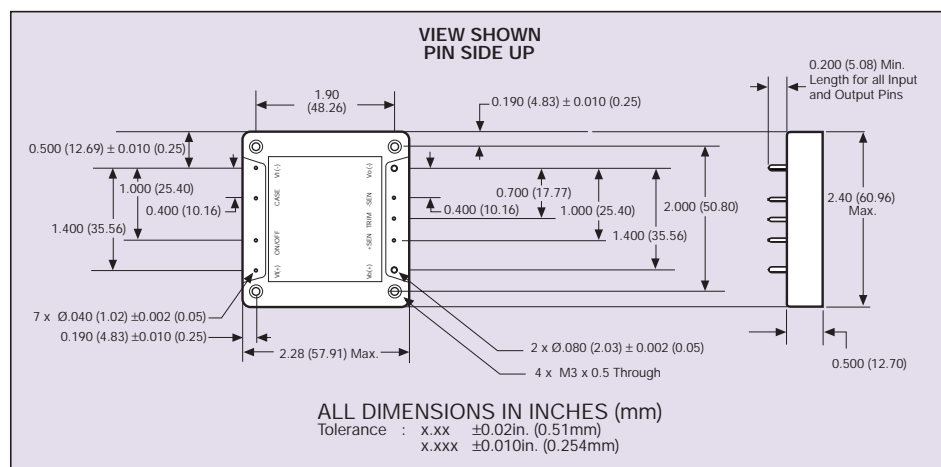

Data Sheet © Artesyn Technologies® 2002
 The information and specifications contained in this data sheet are believed to be correct at time of publication. However, Artesyn Technologies accepts no responsibility for consequences arising from printing errors or inaccuracies. Specifications are subject to change without notice. No rights under any patent accompany the sale of any such product(s) or information contained herein.