

Excellent Integrated System Limited

Stocking Distributor

Click to view price, real time Inventory, Delivery & Lifecycle Information:

[Molex Connector Corporation](#)
[0638136100](#)

For any questions, you can email us directly:

sales@integrated-circuit.com

Extractor Tool for HDX™ Crimp Female Terminals



**Extractor Tool
Instruction Sheet
Order No. 63813-6100**

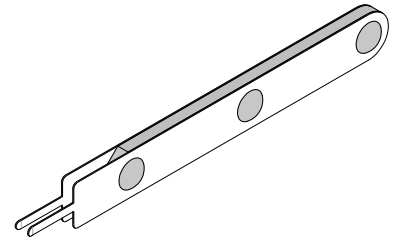

FEATURES

- This Extractor Tool is for the removal of HDX™ Female Crimp Terminals from 15-Way or 30-Way HDX™ Female Module.

SCOPE

Products: HDX™ Female Crimp Terminal 15-Way and 30-Way, 0.635mm (.025"), AWG 20-24 (0.22-0.60mm²).

Terminal Series No.	Module Order No.			Terminal Order No.	
98587	98627-0001	98627-1001	98627-1002	98587-0013	98587-0014

Warning: Before extracting the crimp terminals, the wire cap assembly will need to be removed. See ATS-638136300 for instructions. See Figure 1.
The Female Module will also need to be removed from the Standard Frame Module. See ATS-638136200 for instructions. See Figure 1.

OPERATION:

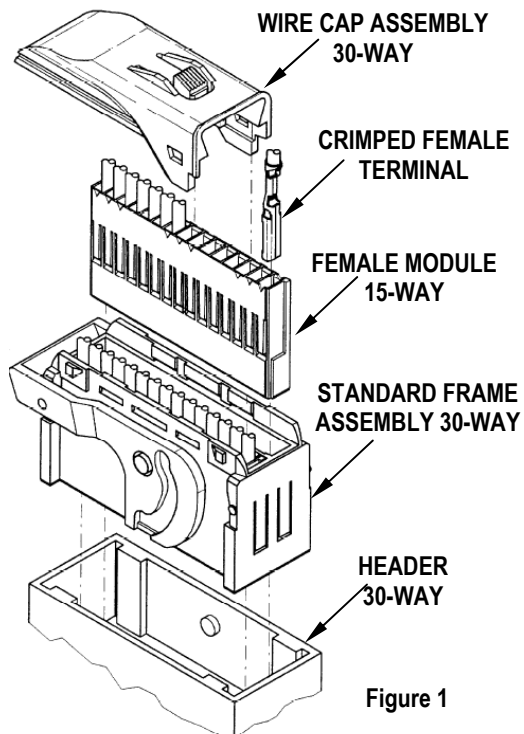

Figure 1

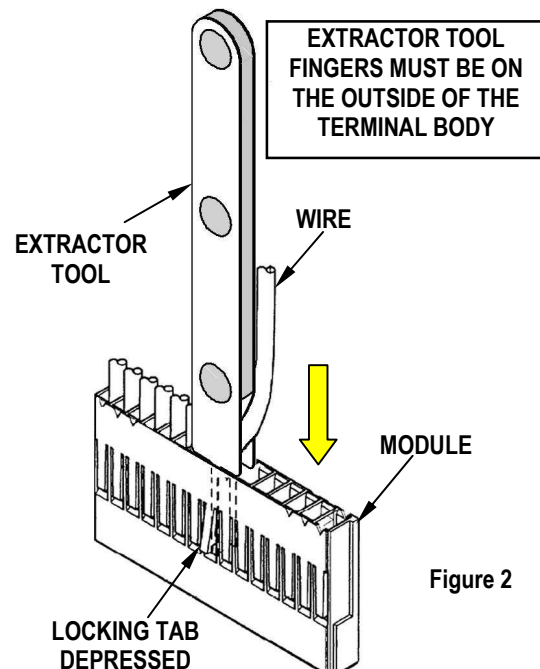

Figure 2

1. Insert the extractor tool into the module as shown in Figure 2.

Extractor Tool for HDX™ Crimp Female Terminals

2. Use the slots located on the inside of the module to guide the extraction tool blades into the module until contact is made with the terminal.
3. Continue to insert the tool, always checking to see that the blades of extraction tool are on the outside of the terminal's body.
4. Continue to insert extraction tool into module until the locking tabs of the module have been depressed. See Figure 2.
5. Gently pull the extractor tool along with the crimped wire, out from the module.
6. Molex does not offer repair parts for this Tools due to the inexpensive nature of the tool.

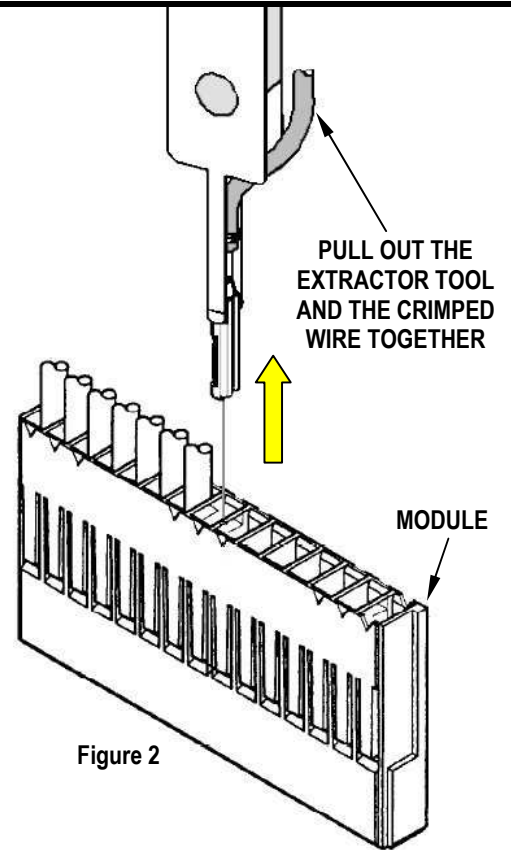

Figure 2

CAUTION: Molex specifications are valid only when used with Molex terminals, modules, and tooling.

Contact Information

For more information on Molex application tooling please contact Molex at 1-800-786-6539.

Americas Headquarters
Lisle, Illinois 60532 U.S.A.
1-800-78MOLEX
amerinfo@molex.com

Far East North Headquarters
Yamato, Kanagawa, Japan
81-462-65-2324
feninfo@molex.com

Far East South Headquarters
Jurong, Singapore
65-6-268-6868
fesinfo@molex.com

European Headquarters
Munich, Germany
49-89-413092-0
eurinfo@molex.com

Corporate Headquarters
2222 Wellington Ct.
Lisle, IL 60532 U.S.A.
630-969-4550
Fax: 630-969-1352

Visit our Web site at <http://www.molex.com>