

Excellent Integrated System Limited

Stocking Distributor

Click to view price, real time Inventory, Delivery & Lifecycle Information:

[Panduit](#)
[PC038-H25D-C0](#)

For any questions, you can email us directly:
sales@integrated-circuit.com

THIS COPY IS PROVIDED ON A RESTRICTED BASIS AND IS NOT TO BE USED IN ANY WAY DETRIMENTAL TO THE INTERESTS OF PANDUIT CORP.

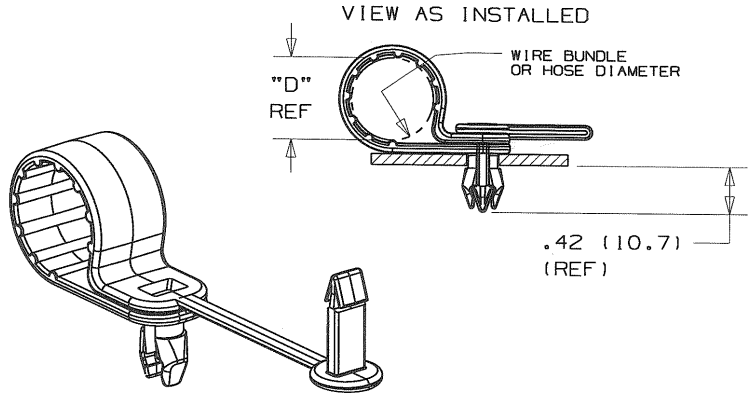
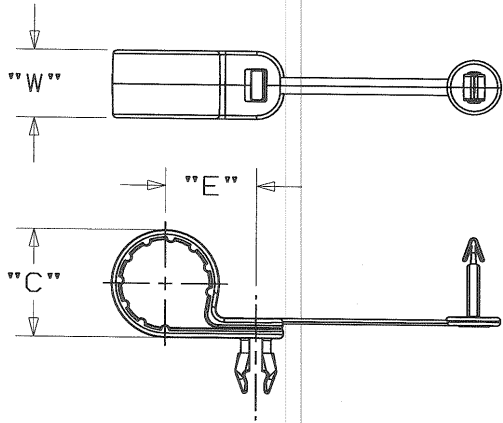

SCALE: FULL

NOTES:

- SEE CURRENT PRICE SHEET FOR PART NUMBER SUFFIX DESIGNATION FOR PACKAGE SIZE AND COLOR.
- MOUNTING HOLE DIAMETER: 1/4" CLEARANCE - .281" (7mm) PANEL THICKNESS: .125" (3.2mm) NOMINAL
- SPECIFIED DIAMETER IS CABLE OR HOSE THAT IS BEING INSTALLED.

PANDUIT PART NO. (SEE NOTE 1)	DIMENSIONS				WEIGHT lbs / (g) 100/ pcs
	"C"	"D" DIAMETER REF SEE NOTE 3	"E" (REF.)	"W"	
PC038-H25D-_-	.58 (14.7)	.38 (9.5)	.64 (16.3)	.62 (15.7)	.74 / (1340)
PC050-H25D-_-	.70 (17.8)	.50 (12.7)	.71 (17.9)		.83 / (1380)
PC062-H25D-_-	.82 (20.8)	.62 (15.8)	.77 (19.5)		.92 / (1420)
PC075-H25D-_-	.95 (24.1)	.75 (19.1)	.83 (21.1)		1.02 / (1465)
PC087-H25D-_-	1.07 (27.2)	.87 (22.1)	.89 (22.7)		1.11 / (1505)
PC100-H25D-_-	1.20 (30.5)	1.00 (25.4)	.96 (24.3)		1.21 / (1550)
PC112-H25D-_-	1.33 (33.8)	1.12 (28.5)	1.02 (25.8)		1.29 / (1585)
PC125-H25D-_-	1.45 (36.8)	1.25 (31.8)	1.08 (27.4)		1.37 / (1620)

DIMENSIONS IN BRACKETS ARE METRIC [mm]

CAD FILENAME/LAYERS G035971D_DC_GB2320CA/00B

PANDUIT CORP. TINLEY PARK, ILLINOIS

PAN-CLAMP
(PC___-H25D-_-)

UNLESS OTHERWISE SPECIFIED,
 DIMENSIONAL TOLERANCES ARE:
 (.X) ±0.05 (1.3) (.XXX) ±0.010 (0.25)
 (.XX) ±0.02 (0.5) ANGLES ±5°

UNLESS OTHERWISE SPECIFIED,
 ALL DIMENSIONS ARE GIVEN
 IN INCHES, THIRD ANGLE PROJECTION.

REV	DATE	BY	CHK	DESCRIPTION	ECN	R	CUST	SUP
00B	02/24/09	GDH		CHANGED REVISION STYLE AND FILE NAME FORMAT. ADDED COLUMN "C".	GB2320CA	00B		
5	5/9/01	KLN		UPDATED PART WEIGHTS, E, AND W DIMENSIONS	GB2320CA	5		
4	3/22/01	KLN		UPDATED PRODUCT PART NUMBERS	GB2320CA	4		

DRAWN BY JAD

MAT'L:

SCALE 3/4

DATE 4-26-00

WEATHER RESISTANT
 IMPACT MODIFIED
 NYLON 6/6

DRAWING NO. GB2320CA

CHK'D KLN

DWG
 SIZE
 A