

## Excellent Integrated System Limited

Stocking Distributor

Click to view price, real time Inventory, Delivery & Lifecycle Information:

[FCI](#)  
[10078993-G01-06ULF](#)

For any questions, you can email us directly:  
[sales@integrated-circuit.com](mailto:sales@integrated-circuit.com)

10078993-G0X-XXYLF

PLATING  
0.76 µm GXT (Pd Ni with gold flash)  
over 1.27 µm Nickel underplate

LATCH TYPE:  
1 = STANDARD : For use with STRAIN-RELIEF 10073978  
2 = LOW PROFILE : For use without STRAIN-RELIEF

SIZE : TOTAL NB OF POSITIONS  
SEE SHEET 2

PACKAGING, SEE NOTE 4.

RoHS COMPATIBLE, SEE NOTE 5.

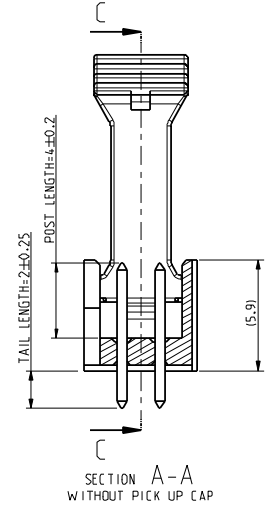
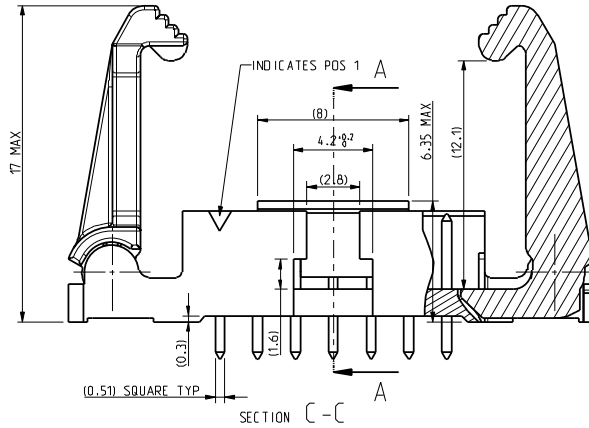
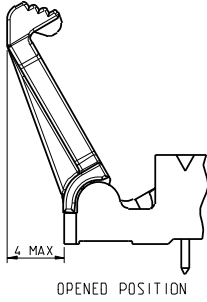
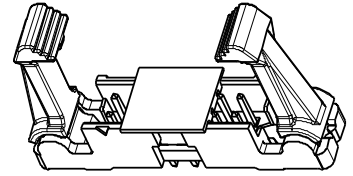
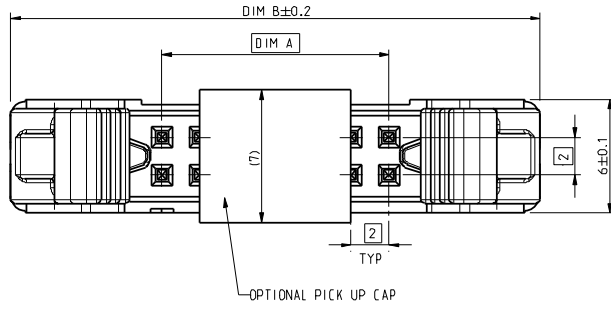

- NOTES :
- MATERIAL HOUSING : HIGH TEMPERATURE THERMOPLASTIC UL 94 V0, COLOR CREAM.  
- MATERIAL LATCH : HIGH TEMPERATURE THERMOPLASTIC UL 94 V0, COLOR BLACK.
  - MATERIAL TERMINAL : COPPER ALLOY
  - PIN RETENTION IN EITHER DIRECTION : 7N MIN
  - PACKAGING  
U= TUBE WITHOUT PICK UP CAP .  
A= TAPE & REEL WITH PICK UP CAP.
  - ROHS COMPATIBLE PRODUCT SPECIFICATIONS :  
a- PLATING :  
"LF" MEANS THE PRODUCT IS LEAD FREE  
2µm MATTE TIN MIN ON TAIL OVER 1.27µm NICKEL UNDERPLATE.  
b- MANUFACTURING PROCESS COMPATIBILITY  
THE HOUSING WILL WITHSTAND EXPOSURE TO 260°C PEAK TEMPERATURE FOR 30 SECONDS MAX IN A CONVECTION, INFRA RED, VAPOR PHASE OR REFLOW OVEN.  
c- LABELLING  
MEETS PACKAGING SPECS AS PER GS-14-920.  
d- THIS PRODUCT MEETS EUROPEAN DIRECTIVES AND OTHER CONTRY REGULATION AS DESCRIBED IN GS-47-0004

rev	ecn no	dr	date
A	F08-0110	LSA	08-01-16
B	B-19190	LMU	14-11-07
-	-	-	-
-	-	-	-
-	-	-	-

www.fciconnect.com		surface ISO 1302	tolerance std ISO 406	ISO 1101	projection mm	mm
		TOLERANCES UNLESS OTHERWISE SPECIFIED				
Dr	NEBU PM	07-06-19	ANGULAR	LINEAR	size	Scale
Eng	JM COMPAGNON	07-06-19			A3	5:1
Chr	JM COMPAGNON	07-06-19	0° ±	0.xxx ±	ECN	B-19190
Appr	L. SAILLARD	07-06-19	Product family		Spec ref	-
<b>FCI</b>		<b>EJECT LATCH HEADER</b>		dwg no	10078993	Rev.
		VERTICAL PIP				B
catalog no		CUSTOMER		sheet 1 of 2		

Copyright FCI

SIZE	POSITIONS	DIM A	DIM B
06	2x3	4.00	20.00
08	2x4	6.00	22.00
10	2x5	8.00	24.00
12	2x6	10.00	26.00
14	2x7	12.00	28.00
24	2x12	22.00	38.00
30	2x15	28.00	44.00
40	2x20	38.00	54.00
44	2x22	42.00	58.00
50	2x25	48.00	64.00

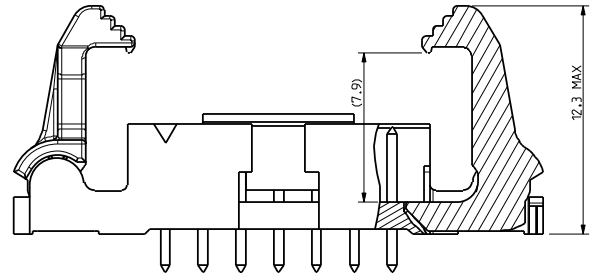
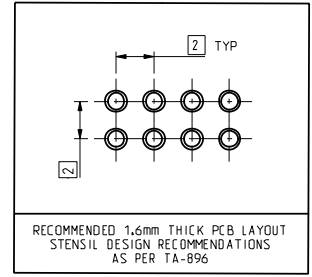
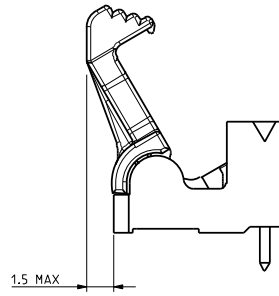

SECTION C - C  
 EXAMPLE 10078993-G02-14YLF  
 LOW PROFILE LATCH

PRODUCT USED IN COMBINATION WITH IDC  
 RECEPTACLE P/NS 89361 & 89941

<p>WITH STRAIN-RELIEF ACCESSORY          - STANDARD LATCH -</p>	<p>WITHOUT STRAIN-RELIEF ACCESSORY          - LOW PROFILE LATCH -</p>
---	---

www.fciconnect.com		surface ISO 1302	-	tolerance std ISO 406	ISO 1101	projection A	mm
TOLERANCES UNLESS OTHERWISE SPECIFIED							
Dr	NEBU PM	07-06-19	ANGULAR	0.x	±/	size	Scale
Eng	JM COMPAGNON	07-06-19	LINEAR	0.xx	±/	A3	5:1
Chr	JM COMPAGNON	07-06-19	0° ±/°	0.xxx	±/	ECN	B-19190
Appr	L. SAILLARD	07-06-19	Product family	-		Spec ref	-
<b>FCI</b>		Title EJECT LATCH HEADER		Dwg no 10078993		Rev. B	
catalog no		CUSTOMER		sheet 2 of 2			

Copyright FCI.

PDS: Rev: B

STATUS: Released

Printed: Nov 13, 2014