

Excellent Integrated System Limited

Stocking Distributor

Click to view price, real time Inventory, Delivery & Lifecycle Information:

[Harting](#)

[09330009910](#)

For any questions, you can email us directly:

sales@integrated-circuit.com

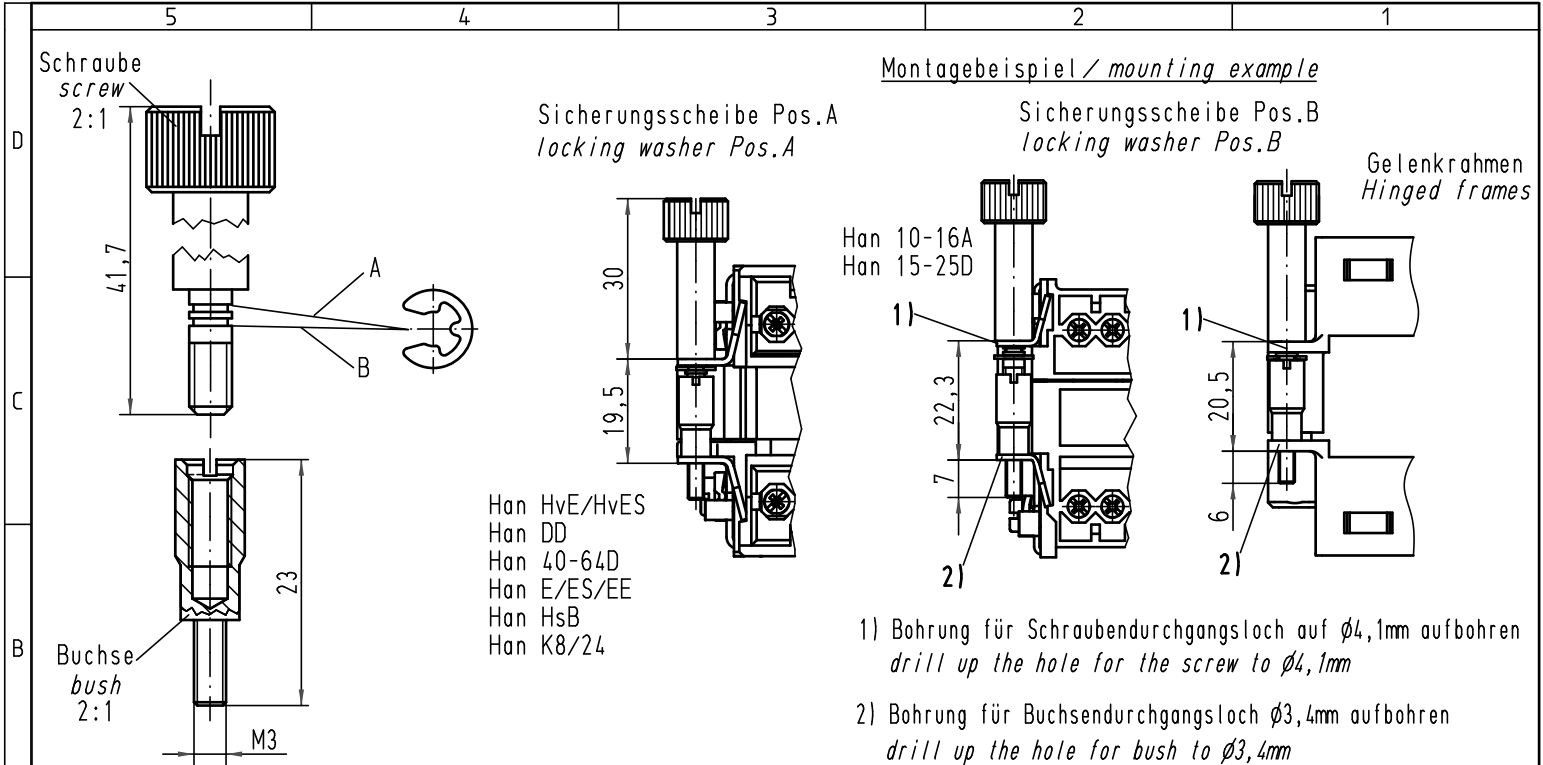

Montagebeispiel / mounting example

Sicherungsscheibe Pos.A
locking washer Pos.A

Sicherungsscheibe Pos.B
locking washer Pos.B

Gelenkrahmen
Hinged frames

Han 10-16A
Han 15-25D

1) Bohrung für Schraubendurchgangsloch auf $\phi 4,1\text{mm}$ aufbohren
drill up the hole for the screw to $\phi 4,1\text{mm}$

2) Bohrung für Buchsendurchgangsloch $\phi 3,4\text{mm}$ aufbohren
drill up the hole for bush to $\phi 3,4\text{mm}$

			All Dimensions in mm Original Size DIN A 4		Techn. Character.			Nicht tolerierte Masse / Free size tolerances																	
					<table border="1"> <tr> <td>Detail.</td> <td>Dat.</td> <td>Name</td> <td rowspan="3">Massstab / Scale</td> </tr> <tr> <td>Insp.</td> <td>12.03.93</td> <td>WILD</td> </tr> <tr> <td>Stand.</td> <td></td> <td>HERB</td> </tr> </table>		Detail.	Dat.	Name	Massstab / Scale	Insp.	12.03.93	WILD	Stand.		HERB	<p>Schraubverbindung special insert fixing screw</p>								
Detail.	Dat.	Name	Massstab / Scale																						
Insp.	12.03.93	WILD																							
Stand.		HERB																							
			<table border="1"> <tr> <td>413895</td> <td>27.05.08</td> <td>Rull</td> </tr> <tr> <td>411037</td> <td>18.05.04</td> <td>Loe.</td> </tr> </table>		413895	27.05.08	Rull	411037	18.05.04	Loe.															
413895	27.05.08	Rull																							
411037	18.05.04	Loe.																							
			<table border="1"> <tr> <td>09 33 000 9912</td> <td>Buchse / bush</td> <td>23467</td> <td>15.06.98</td> <td>Sper</td> </tr> <tr> <td>09 33 000 9910</td> <td>Schraube / screw</td> <td>21020</td> <td>23.01.97</td> <td>ROH</td> </tr> </table>		09 33 000 9912	Buchse / bush	23467	15.06.98	Sper	09 33 000 9910	Schraube / screw	21020	23.01.97	ROH	<table border="1"> <tr> <td colspan="2">HARTING Electric GmbH & Co. KG</td> <td rowspan="2"> </td> <td rowspan="2"> TB 09 33 000 991. </td> <td rowspan="2">Blatt / page</td> </tr> <tr> <td colspan="2">D-32339 Espelkamp</td> <td>Sub.</td> </tr> </table>			HARTING Electric GmbH & Co. KG			TB 09 33 000 991.	Blatt / page	D-32339 Espelkamp		Sub.
09 33 000 9912	Buchse / bush	23467	15.06.98	Sper																					
09 33 000 9910	Schraube / screw	21020	23.01.97	ROH																					
HARTING Electric GmbH & Co. KG			TB 09 33 000 991.	Blatt / page																					
D-32339 Espelkamp					Sub.																				
Bestell Nr / Part No			Bezeichn. / Identif.		Mod.		Dat.		Name																