



Excellent Integrated System Limited

Stocking Distributor

Click to view price, real time Inventory, Delivery & Lifecycle Information:

[BUD Industries, Inc.](#)
[DC-8075-BT](#)

For any questions, you can email us directly:
sales@integrated-circuit.com

PART NAME	MISSION CRITICAL CABINET	PART No.	DC-8075
-----------	--------------------------	----------	---------

MATERIAL:

SIDES & REAR DOOR _____ 20 GA. STEEL
 REAR DOOR STIFFENER _____ 18 GA. STEEL
 TOP, BOTTOM, RAIL SUPPORTS, PLATES
 & DOOR STOPS _____ 16 GA. STEEL
 VERTICAL RAILS _____ 14 GA. STEEL
 PANEL MOUNTING RAILS
 & LEVELER MOUNTING BRACKETS _____ 12 GA. STEEL
 PLEXIGLAS DOOR FRAME _____ ALUMINUM EXTRUSION
 PLEXIGLAS PANEL _____ 3/16" THICK

FINISH:

FRAME ASSEMBLY, SIDES, PLATES,
 REAR DOOR & REAR DOOR HINGES _____ WHITE TEXTURE
 _____ BLACK TEXTURE
 PLEXIGLAS DOOR HINGES _____ METALLIC GRAY
 PANEL MOUNTING RAILS, DOOR STOPS
 & LEVELER MOUNTING BRACKETS _____ SMOOTH BLACK
 PLEXIGLAS DOOR FRAME _____ CLEAR ANODIZED
 PLEXIGLAS PANEL _____ SMOKE GRAY

LOAD RATING: 1200 LBS. MAX.

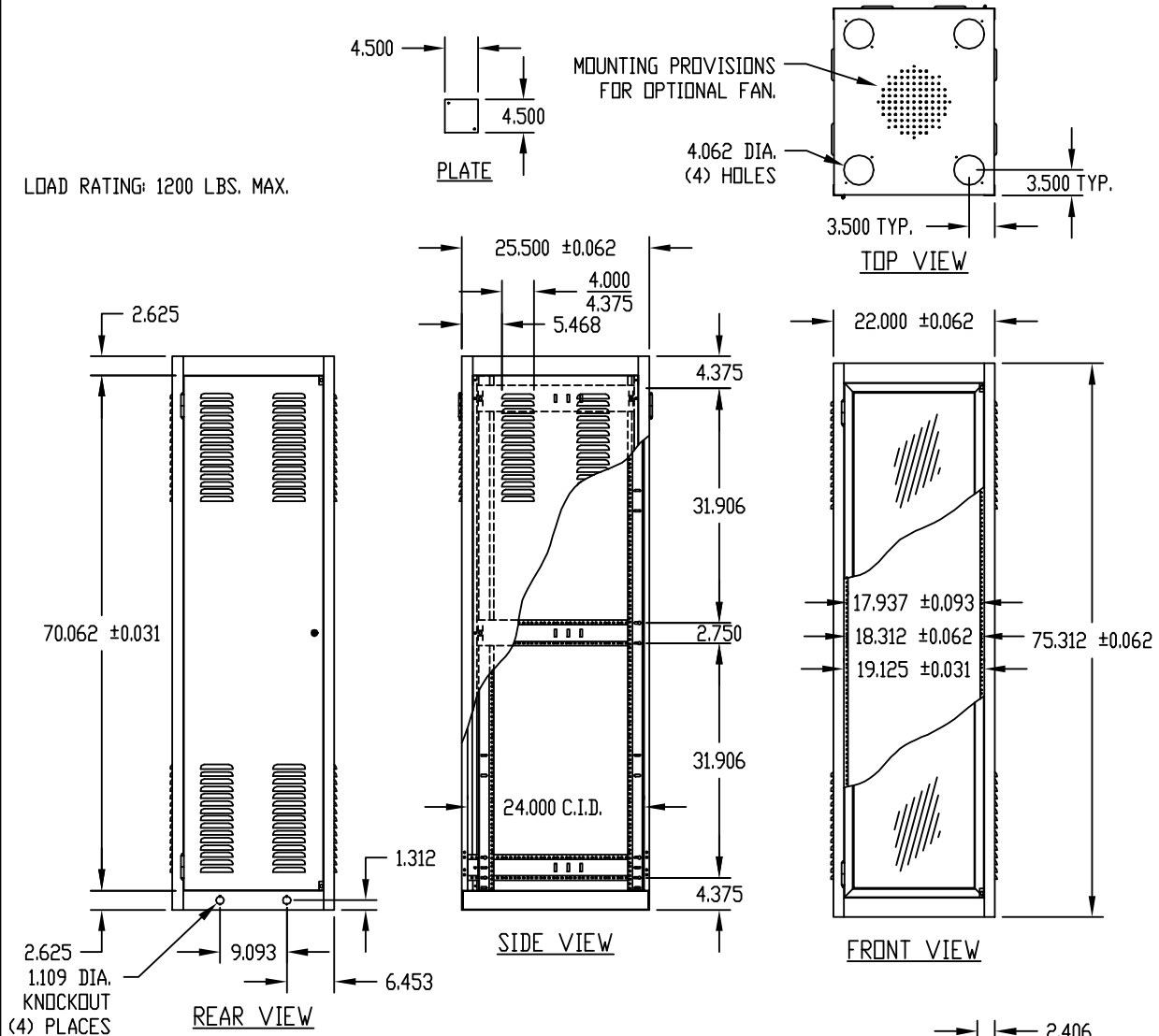

NOTES:

- ① PANEL MOUNTING RAILS TAPPED #10-32 ON E.I.A. UNIVERSAL SPACING AND ARE FULLY ADJUSTABLE.
- ② MOUNTING HOLES PIERCED IN BASE FOR #RL-7770 LEVELER KIT. LEVELER KIT WILL RAISE CABINET RACK APPROXIMATELY 1.188 INCHES OFF THE FLOOR.
- ③ LEVELER KIT TO BE SHIPPED UNASSEMBLED, PACKED INSIDE RACK.
- ④ SIDES SHIPPED ASSEMBLED WITH TEMPORARY NYLON PUSH FASTENERS. CUSTOMER TO DO FINAL ASSEMBLY WITH #7346 SCREWS AND #295 NUT RETAINERS PROVIDED IN HARDWARE.

9.561 SQUARE CUTOUT

