

Excellent Integrated System Limited

Stocking Distributor

Click to view price, real time Inventory, Delivery & Lifecycle Information:

[Molex Connector Corporation](#)
[0640011200](#)

For any questions, you can email us directly:

sales@integrated-circuit.com

RHT 2050 Hand Crimp Tool



**Hand Crimp Tool Operating Instruction
 And Specifications Sheet
 Order No. 64001-1200
 Eng. No. RHT 2050
 (Replaces 19285-0010)**

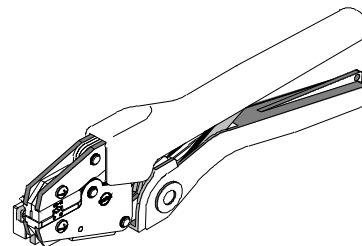

FEATURES

- A full cycle ratcheting hand tool ensures complete crimps
- Long handles for comfortable crimping with reduced crimping force
- A precision user-friendly terminal locator wire stop holds terminals in the proper crimping position
- Insulation crimp adjustment allows a precise insulation crimp. To meet or exceed the requirements of UL, CSA and Military Class II
- Single color-coded crimp pocket eliminates the possibility of using the wrong pocket

SCOPE

AviKrimp® and InsulKrimp® Terminals 18–22 AWG, (Rings, Spades, Hooks, Snap Spades, Flanged Spades and Wire Pin Terminals.). Short Barrel. Some Male Quick Disconnects Terminals

Testing

Mechanical

The tensile test, or pull test, is a means of evaluating the mechanical properties of the crimped connections. The following charts show the UL and Government specifications (MIL-T-7928) for various wire sizes. The tensile strength is shown in pounds and indicates the minimum acceptable force to break or separate the terminal from the conductor.

Wire Size (AWG)	*UL - 486 A	**Military Class 2
22	8	15
20	13	19
18	20	38

*UL - 486 A - Terminals (Copper conductors only)
 **Military Class 2– Military Approved Terminals only as listed

The following is a partial list of the product part numbers and their specifications that this tool is designed to run. We will be adding to this list and an up to date copy is available on www.molex.com.

Wire Size: 18 – 22 AWG 0.80 – 0.35 mm ²					
Terminal No.	Terminal Eng No. (REF)	Wire Strip Length		Insul. Dia. Max.	
		In	mm	In	mm
19023-0007	AMMCT-2X	.234	5.95	.144	3.68
19070-0001	AA-2111-02X	.234	5.95	.144	3.68
19070-0003	AA-2111-04X	.234	5.95	.144	3.68
19070-0005	AA-220-02X	.234	5.95	.144	3.68
19070-0009	AA-220-04X	.234	5.95	.144	3.68
19070-0011	AA-220-06X	.234	5.95	.144	3.68
19070-0013	AA-221-06X	.234	5.95	.144	3.68
19070-0015	AA-221-08X	.234	5.95	.144	3.68
19070-0015	AA-221-10X	.234	5.95	.144	3.68
19070-0016	AA-221-10XR90	.234	5.95	.144	3.68

Wire Size: 18 – 22 AWG 0.80 – 0.35 mm ²					
Terminal No.	Terminal	Wire Strip Length		Insul. Dia. Max.	
		In	mm	In	mm
19070-0018	AA-221-10XT45	.234	5.95	.144	3.68
19070-0019	AA-221-209X	.234	5.95	.144	3.68
19070-0021	AA-222-10X	.234	5.95	.144	3.68
19070-0023	AA-222-14X	.234	5.95	.144	3.68
19070-0026	AA-222-56X	.234	5.95	.144	3.68
19070-0029	AA-226-10X	.234	5.95	.144	3.68
19070-0031	AA-226-14X	.234	5.95	.144	3.68
19070-0033	AA-226-38X	.234	5.95	.144	3.68
19070-0036	AA-226-56X	.234	5.95	.144	3.68
19070-0038	AA-232-04X	.234	5.95	.144	3.68

RHT 2050 Hand Crimp Tool

Wire Size: 18 – 22 AWG 0.80 – 0.35 mm ²						Wire Size: 18 – 22 AWG 0.80 – 0.35 mm ²					
Terminal No.	Terminal Eng No. (REF)	Wire Strip Length		Insul. Dia. Max.		Terminal No.	Terminal	Wire Strip Length		Insul. Dia. Max.	
		In	mm	In	mm			In	mm		
19070-0040	AA-232-06X	.234	5.95	.144	3.68	19092-0011	AA-6110-04X	.234	5.95	.144	3.68
19070-0044	AA-232-08X	.234	5.95	.144	3.68	19092-0013	AA-614-04X	.234	5.95	.144	3.68
19070-0051	AA-233-10X	.234	5.95	.144	3.68	19092-0015	AA-614-06X	.234	5.95	.144	3.68
19070-0394	AA-220-06XR90	.234	5.95	.144	3.68	19092-0017	AA-614-08X	.234	5.95	.144	3.68
19071-0001	AA-6111-02X	.234	5.95	.144	3.68	19092-0019	AA-692-06X	.234	5.95	.144	3.68
19071-0003	AA-6111-04X	.234	5.95	.144	3.68	19092-0021	AA-692-08X	.234	5.95	.144	3.68
19071-0005	AA-620-02X	.234	5.95	.144	3.68	19092-0023	AA-692-10X	.234	5.95	.144	3.68
19071-0007	AA-620-04X	.234	5.95	.144	3.68	19092-0025	AA-695-06X	.234	5.95	.144	3.68
19071-0009	AA-620-06X	.234	5.95	.144	3.68	19092-0027	AA-695-08X	.234	5.95	.144	3.68
19071-0011	AA-621-06X	.234	5.95	.144	3.68	19092-0029	AA-695-10X	.234	5.95	.144	3.68
19071-0013	AA-621-08X	.234	5.95	.144	3.68	19092-0031	AA-698-04X	.234	5.95	.144	3.68
19071-0015	AA-621-10X	.234	5.95	.144	3.68	19092-0033	AA-698-06X	.234	5.95	.144	3.68
19071-0017	AA-622-10X	.234	5.95	.144	3.68	19092-0035	AA-698-08X	.234	5.95	.144	3.68
19071-0019	AA-622-14X	.234	5.95	.144	3.68	19092-0037	AA-698-10X	.234	5.95	.144	3.68
19071-0021	AA-622-56X	.234	5.95	.144	3.68	19095-0001	AA-805-04	.250	6.35	.140	3.56
19071-0023	AA-626-10X	.234	5.95	.144	3.68	19095-0003	AA-805-06	.250	6.35	.140	3.56
19071-0024	AA-626-14X	.234	5.95	.144	3.68	19095-0016	AA-814-04	.250	6.35	.144	3.68
19071-0026	AA-626-38X	.234	5.95	.144	3.68	19095-0018	AA-814-06	.250	6.35	.144	3.68
19071-0028	AA-626-56X	.234	5.95	.144	3.68	19095-0020	AA-814-08	.250	6.35	.144	3.68
19071-0030	AA-632-04X	.234	5.95	.144	3.68	19095-0036	AA-892-06	.250	6.35	.140	3.56
19071-0032	AA-632-06X	.234	5.95	.144	3.68	19095-0038	AA-892-08	.250	6.35	.140	3.56
19071-0034	AA-632-08X	.234	5.95	.144	3.68	19095-0040	AA-892-10	.250	6.35	.140	3.56
19071-0040	AA-633-10X	.234	5.95	.144	3.68	19095-0042	AA-895-06	.250	6.35	.140	3.56
19073-0001	AA-8111-02	.250	6.35	.140	3.56	19095-0044	AA-895-08	.250	6.35	.140	3.56
19073-0003	AA-8111-04	.250	6.35	.144	3.68	19095-0046	AA-895-10	.250	6.35	.140	3.56
19073-0005	AA-820-02	.250	6.35	.144	3.68	19095-0048	AA-898-04	.250	6.35	.140	3.56
19073-0007	AA-820-04	.250	6.35	.144	3.68	19095-0050	AA-898-06	.250	6.35	.140	3.56
19073-0009	AA-820-06	.250	6.35	.144	3.68	19095-0052	AA-898-08	.250	6.35	.140	3.56
19073-0011	AA-821-06	.250	6.35	.144	3.68	19095-0054	AA-898-10	.250	6.35	.140	3.56
19073-0013	AA-821-08	.250	6.35	.144	3.68	19095-0142	AA-8110-02	.250	6.35		
19073-0017	AA-821-10	.250	6.35	.144	3.68	19099-0001	AA-2190-06X	.234	5.95	.144	3.68
19073-0020	AA-821-209	.250	6.35	.140	3.56	19099-0003	AA-2191-08X	.234	5.95	.144	3.68
19073-0022	AA-822-10	.250	6.35	.140	3.56	19099-0005	AA-2192-10X	.234	5.95	.144	3.68
19073-0024	AA-822-14	.250	6.35	.144	3.68	19099-0007	AA-2704-05X	.234	5.95	.144	3.68
19073-0025	AA-822-14R90	.250	6.35	.140	3.56	19099-0009	AA-2704-06X	.234	5.95	.144	3.68
19073-0027	AA-822-56	.250	6.35	.144	3.68	19099-0011	AA-2705-08X	.234	5.95	.144	3.68
19073-0029	AA-826-10	.250	6.35	.140	3.56	19099-0012	AA-2706-10X	.234	5.95	.144	3.68
19073-0030	AA-826-14	.250	6.35	.140	3.56	19099-0013	AA-2714-08X	.234	5.95	.144	3.68
19073-0032	AA-826-38	.250	6.35	.144	3.68	19099-0015	AA-2715-10X	.234	5.95	.144	3.68
19073-0034	AA-826-56	.250	6.35	.140	3.56	19099-0081	AA-2704-04X	.234	5.95	.144	3.68
19073-0036	AA-832-04	.250	6.35	.144	3.68	19115-0001	AA-8190-06	.250	6.35	.144	3.68
19073-0038	AA-832-06	.250	6.35	.144	3.68	19115-0003	AA-8191-08	.250	6.35	.144	3.68
19073-0042	AA-832-08	.250	6.35	.144	3.68	19115-0005	AA-8192-10	.250	6.35	.144	3.68
19073-0049	AA-833-10	.250	6.35	.144	3.68	19115-0007	AA-8704-05	.250	6.35	.140	3.56
19073-0303	AA-832-06R90	.250	6.35	.140	3.56	19115-0009	AA-8704-06	.250	6.35	.140	3.56
19090-0001	AA-205-04X	.234	5.95	.144	3.68	19115-0011	AA-8705-08	.234	5.95	.144	3.68
19090-0002	AA-205-06X	.234	5.95	.144	3.68	19115-0012	AA-8714-08	.250	6.35	.140	3.56
19090-0007	AA-2110-02X	.234	5.95	.144	3.68	19115-0014	AA-8715-10	.250	6.35	.140	3.56
19090-0009	AA-2110-04X	.234	5.95	.144	3.68	19115-0052	AA-8706-10	.234	5.95	.144	3.68
19090-0011	AA-214-04X	.234	5.95	.144	3.68	19121-0001	AA-2108-02X	.234	5.95	.144	3.68
19090-0013	AA-214-06X	.234	5.95	.144	3.68	19121-0002	AA-2108-04X	.234	5.84	.140	3.56
19090-0024	AA-292-06X	.234	5.95	.144	3.68	19121-0004	AA-215-04X	.234	5.95	.144	3.68
19090-0026	AA-292-08X	.234	5.95	.144	3.68	19121-0005	AA-215-06X	.234	5.84	.144	3.68
19090-0028	AA-292-10X	.234	5.95	.144	3.68	19121-0007	AA-215-08X	.234	5.84	.144	3.68
19090-0030	AA-295-06X	.234	5.95	.144	3.68	19121-0009	AA-215-10X	.234	5.84	.144	3.68
19090-0032	AA-295-08X	.234	5.95	.144	3.68	19121-0011	AA-2461-04X	.234	5.95	.144	3.68
19090-0034	AA-295-10X	.234	5.95	.144	3.68	19121-0012	AA-2461-06X	.234	5.95	.144	3.68
19090-0036	AA-298-04X	.234	5.95	.144	3.68	19121-0013	AA-2461-08X	.234	5.95	.144	3.68
19090-0038	AA-298-06X	.234	5.95	.144	3.68	19121-0014	AA-2461-10X	.234	5.95	.144	3.68
19090-0040	AA-298-08X	.234	5.95	.144	3.68	19121-0015	AA-290-06X	.234	5.95	.144	3.68
19090-0042	AA-298-10X	.234	5.95	.144	3.68	19121-0016	AA-290-08X	.234	5.95	.144	3.68
19092-0001	AA-605-04X	.234	5.95	.144	3.68	19121-0017	AA-290-10X	.234	5.95	.144	3.68
19092-0003	AA-605-06X	.234	5.95	.144	3.68	19121-0018	AA-293-06X	.234	5.95	.144	3.68
19092-0009	AA-6110-02X	.234	5.95	.144	3.68	19121-0019	AA-293-08X	.234	5.95	.144	3.68

RHT 2050 Hand Crimp Tool

Wire Size: 18 – 22 AWG 0.80 – 0.35 mm ²					
Terminal No.	Terminal Eng No. (REF)	Wire Strip Length		Insul. Dia. Max.	
		In	mm	In	mm
19121-0020	AA-293-10X	.234	5.95	.144	3.68
19121-0021	AA-296-04X	.234	5.95	.144	3.68
19121-0022	AA-296-06X	.234	5.84	.144	3.68
19121-0024	AA-296-08X	.234	5.95	.144	3.68
19122-0001	AA-6108-02X	.234	5.95	.144	3.68
19122-0003	AA-6108-04X	.234	5.95	.144	3.68
19122-0005	AA-615-04X	.234	5.95	.144	3.68
19122-0007	AA-615-06X	.234	5.95	.144	3.68
19122-0009	AA-615-08X	.234	5.95	.144	3.68
19122-0011	AA-690-06X	.234	5.95	.144	3.68
19122-0013	AA-690-08X	.234	5.95	.144	3.68
19122-0015	AA-690-10X	.234	5.95	.144	3.68
19122-0017	AA-693-06X	.234	5.95	.144	3.68
19122-0019	AA-693-08X	.234	5.95	.144	3.68
19122-0021	AA-693-10X	.234	5.95	.144	3.68
19122-0023	AA-696-04X	.234	5.95	.144	3.68
19122-0025	AA-696-06X	.234	5.95	.144	3.68
19127-0001	AA-8108-02	.250	6.35	.140	3.56
19127-0003	AA-8108-04	.250	6.35	.140	3.56
19127-0005	AA-815-04	.250	6.35	.140	3.63
19127-0007	AA-815-06	.250	6.35	.140	3.56
19127-0010	AA-815-08	.250	6.35	.140	3.56
19127-0012	AA-815-10	.250	6.35	.140	3.56
19127-0014	AA-8461-04	.250	6.35	.140	3.56
19127-0015	AA-8461-06	.250	6.35	.140	3.56
19127-0016	AA-8461-08	.250	6.35	.140	3.56
19127-0017	AA-8461-10	.250	6.35	.140	3.56
19127-0019	AA-890-06	.250	6.35	.140	3.56
19127-0021	AA-890-08	.250	6.35	.140	3.56
19127-0023	AA-890-10	.250	6.35	.140	3.56
19127-0025	AA-893-06	.250	6.35	.140	3.56
19127-0027	AA-893-08	.250	6.35	.140	3.56
19127-0029	AA-893-10	.250	6.35	.140	3.56
19127-0031	AA-896-04	.250	6.35	.140	3.56
19127-0033	AA-896-06	.250	6.35	.140	3.56
19127-0035	AA-896-08	.250	6.35	.140	3.56
19131-0027	AA-294-10X	.234	5.84	.144	3.68
19131-0028	AA-294-08X	.234	5.95	.144	3.68
19131-0029	AA-294-06X	.234	5.95	.144	3.68
19131-0031	AA-238-06X	.234	5.84	.150	3.81
19131-0033	AA-238-04X	.234	5.95	.144	3.68
19131-0034	AA-234-10X	.234	5.95	.144	3.68
19131-0036	AA-234-08X	.234	5.84	.150	3.81
19131-0038	AA-234-06X	.234	5.84	.150	3.81
19131-0039	AA-234-04X	.234	5.95	.144	3.68
19131-0042	AA-2118-06X	.234	5.84	.150	3.81
19131-0045	AA-2109-04X	.234	5.84	.144	3.68
19131-0047	AA-2109-02X	.234	5.84	.144	3.68
19133-0001	AA-634-04X	.234	5.95	.144	3.68
19133-0002	AA-634-06X	.234	5.95	.144	3.68
19133-0003	AA-634-08X	.234	5.95	.144	3.68
19133-0004	AA-634-10X	.234	5.95	.144	3.68
19139-0001	AA-8109-02	.250	6.35	.144	3.68
19139-0003	AA-8109-04	.250	6.35	.144	3.68
19139-0006	AA-8118-06	.250	6.35	.140	3.56
19139-0008	AA-8118-08	.250	6.35	.142	3.63
19139-0009	AA-834-04	.250	6.35	.140	3.56
19139-0011	AA-834-06	.250	6.35	.140	3.56
19139-0013	AA-834-08	.250	6.35	.140	3.56
19139-0015	AA-834-10	.250	6.35	.140	3.56
19139-0016	AA-838-04	.250	6.35	.140	3.56
19139-0018	AA-838-06	.250	6.35	.140	3.56
19139-0020	AA-891-06	.250	6.35	.140	3.56
19139-0022	AA-891-08	.250	6.35	.140	3.56

Wire Size: 18 – 22 AWG 0.80 – 0.35 mm ²					
Terminal No.	Terminal	Wire Strip Length		Insul. Dia. Max.	
		In	mm	In	mm
19139-0024	AA-891-10	.250	6.35	.140	3.56
19139-0026	AA-894-06	.250	6.35	.140	3.56
19139-0028	AA-894-08	.250	6.35	.140	3.56
19139-0030	AA-894-10	.250	6.35	.140	3.56
19139-0032	AA-897-04	.250	6.35	.140	3.56
19139-0034	AA-897-06	.250	6.35	.140	3.56
19139-0036	AA-897-08	.250	6.35	.140	3.56
19144-0001	AA-235-06X	.234	5.84	.150	3.81
19144-0003	AA-235-08X	.234	5.84	.150	3.81
19144-0005	AA-235-10X	.234	5.84	.150	3.81
19144-0007	AA-291-06X	.234	5.95	.144	3.68
19144-0008	AA-291-08X	.234	5.95	.144	3.68
19144-0009	AA-291-10X	.234	5.95	.144	3.68
19144-0010	AA-297-04X	.234	5.95	.144	3.68
19144-0011	AA-297-06X	.234	5.95	.144	3.68
19144-0012	AA-297-08X	.234	5.95	.144	3.68
19145-0001	AA-6109-02X	.234	5.95	.144	3.68
19145-0003	AA-6109-04X	.234	5.95	.144	3.68
19145-0011	AA-635-06X	.234	5.95	.144	3.68
19145-0013	AA-635-08X	.234	5.95	.144	3.68
19145-0015	AA-635-10X	.234	5.95	.144	3.68
19145-0017	AA-638-04X	.234	5.95	.144	3.68
19145-0019	AA-638-06X	.234	5.95	.144	3.68
19145-0022	AA-691-06X	.234	5.95	.144	3.68
19145-0024	AA-691-08X	.234	5.95	.144	3.68
19145-0026	AA-691-10X	.234	5.95	.144	3.68
19145-0028	AA-694-06X	.234	5.95	.144	3.68
19145-0030	AA-694-08X	.234	5.95	.144	3.68
19145-0032	AA-694-10X	.234	5.95	.144	3.68
19145-0034	AA-697-04X	.234	5.95	.144	3.68
19145-0036	AA-697-06X	.234	5.95	.144	3.68
19145-0038	AA-697-08X	.234	5.95	.144	3.68
19179-0002	AA-210-06X	.234	5.84	.150	3.81
19179-0004	AA-210-08X	.234	5.84	.150	3.81
19179-0006	AA-210-10X	.234	5.84	.150	3.81
19182-0001	AA-610-06X	.234	5.95	.144	3.68
19182-0003	AA-610-08X	.234	5.95	.144	3.68
19182-0005	AA-610-10X	.234	5.95	.144	3.68
19183-0001	AA-810-06	.250	6.35	.140	3.56
19183-0003	AA-810-08	.250	6.35	.140	3.56
19183-0005	AA-810-10	.250	6.35	.140	3.56
19198-0004	AA-835-08	.234	5.84	.140	3.56
19198-0006	AA-835-10	.234	5.84	.140	3.56
19198-0070	AA-835-06	.234	5.84	.140	3.56
19212-0003	WP-2218X	.187	4.76	.144	3.68
19213-0003	WP-5218	.187	4.76	.140	3.56
19213-0009	WP-8218	.187	4.76	.140	3.56

MILITARY CLASS 2 Wire Size: 18 – 22 AWG 0.80 – 0.35 mm ²					
Terminal No.	Terminal Eng No. (REF)	Wire Strip Length		Insul. Dia. Max.	
		In	mm	In	mm
19095-0022	AA-880-1	.250	6.35	.140	3.57
19095-0024	AA-881-1	.250	6.35	.140	3.57
19095-0026	AA-882-1	.250	6.35	.140	3.57
19095-0028	AA-883-1	.250	6.35	.140	3.57
19095-0030	AA-884-1	.250	6.35	.140	3.57
19095-0032	AA-885-1	.250	6.35	.140	3.57
19095-0034	AA-886-1	.250	6.35	.140	3.57

RHT 2050 Hand Crimp Tool

OPERATION

Open the tool by first closing the jaws sufficiently for the ratchet mechanism to release.

Crimping Terminals

1. Push up on the locator blade and position the terminal with the barrel facing up into the color-coded nest with front edge of the barrel against the locator (See Figure 1). Release the locator blade to hold the terminal in position.
2. Partially close the tool to hold the terminal in place (See Figure 2).

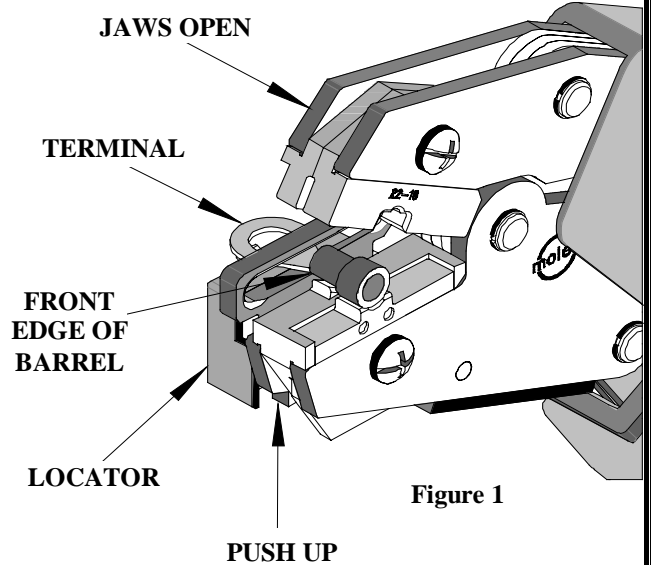

Figure 1

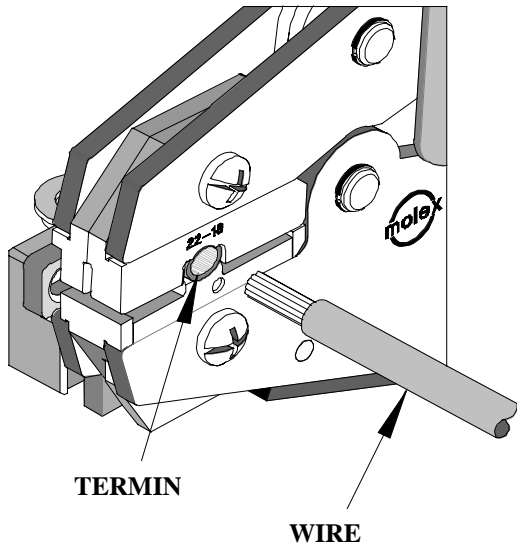

Figure 2

3. Insert the properly stripped wire into the terminal barrel (See Figure 2 and 3). The wires end should butt against the wire stop position of the locator. Cycle the tool.

Note: The tamper proof ratchet action will not release the tool until it has been fully closed.

4. Lift the locator blade or wire stop and remove the crimped terminal. Inspect for proper crimp location, and check for insulation closure. Locator is adjustable up and down to keep terminals straight after crimping.
5. If the insulation part of the crimp needs to be adjusted, first loosen the M4 screw on the bottom tool jaw, then insert a 3/32 hex wrench (supplied) into the bottom of the lower die (See Figure 4). A clockwise (CW) rotation decreases insulation crimp while a counter-clockwise (CCW) rotation increases insulation crimp. After adjusting retighten the M4 screw.

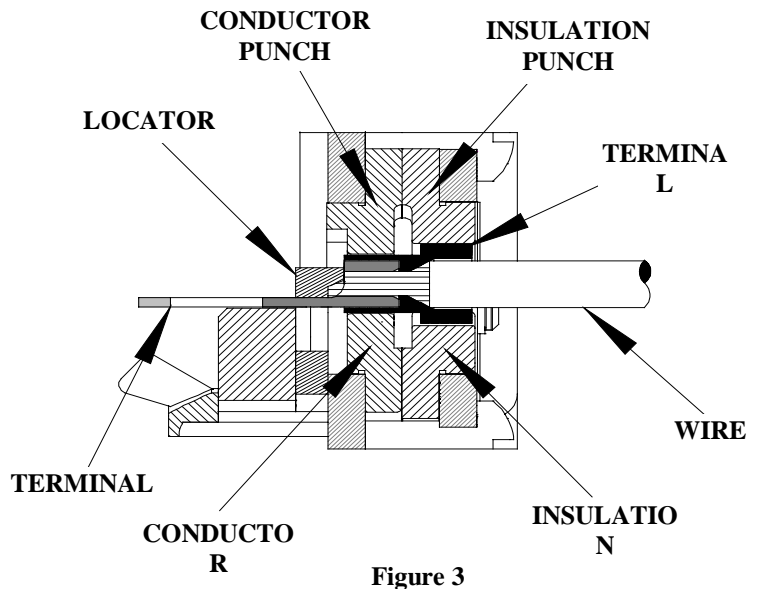

Figure 3

Note: Whenever crimping without the locator, make sure the seam of the terminal is oriented up or down in the tool if using unbrazed product, as this will provide higher pull force values.

RHT 2050 Hand Crimp Tool



RHT 2050 Hand Crimp Tool

Maintenance

It is recommended that each operator of the tool be made aware of, and responsible for, the following maintenance steps:

1. Remove dust, moisture and other contaminants with a clean brush, or soft, lint-free cloth.
2. Do not use any abrasive materials that could damage the tool.
3. Make certain all pins; pivot points and bearing surfaces are protected with a thin coat of high quality machine oil. Do not oil excessively. The 64001-1200 (RHT-2050) was engineered for durability, but like any fine piece of equipment it needs cleaning and lubrication for a maximum service life of trouble-free crimping. A light oil, such as 30 weight automotive oil used at the oil points shown in Figure 4, every 5,000 crimps or 3 months will significantly enhance the tool life and ensure a stable calibration.
4. When tool is not in use, keep the handles closed to prevent objects from becoming lodged in the crimping dies, and store the tool in a clean, dry area.

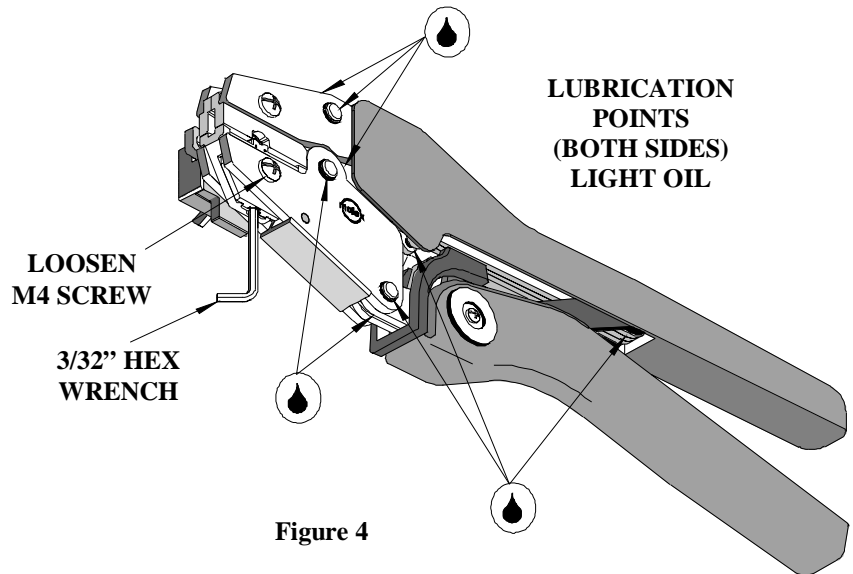

Figure 4

Miscrimps or Jams

Should this tool ever become stuck or jammed in a partially closed position, **Do Not force the handles open or closed**. The tool will open easily by lifting the ratchet release lever (See Fig.5).

How To Adjust Tool Preload (See Figure 5)

Over the life of the tool, it may be necessary to adjust tool handle preload force. Listed below are the steps required to adjust the crimping force of the hand tool to obtain proper crimp conditions:

1. Remove the screw and plastic cover washer. Note the setting wheel position.
2. Lift the setting wheel off the axle. Turn the eccentric axle with a screwdriver.
3. Turning the eccentric axle counter-clockwise (CCW) will increase handle force.
4. Replace the setting wheel to the axle, aligning the nearest notch in the setting wheel to the dowel pin.
5. Replace the plastic cover washer and screw.
6. Check the crimp specifications after tool handle preload force is adjusted.

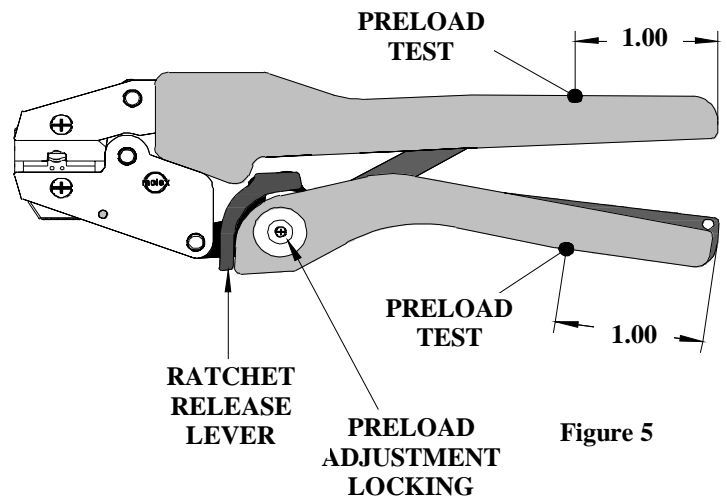
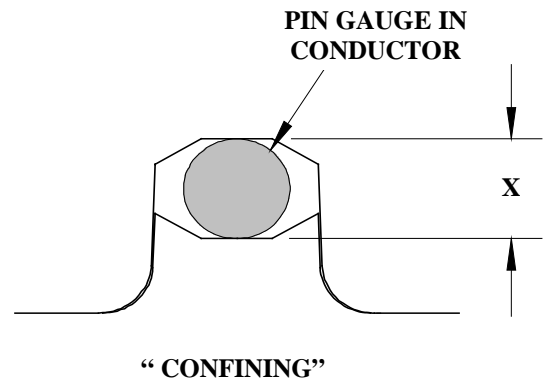

Figure 5

RHT 2050 Hand Crimp Tool

Tool Calibration

A Certificate of Calibration (see last page) was supplied with the tool. To recalibrate this tool, pin gauge measurements should be taken in each conductor nest and compared to this chart. The tool should be lubricated prior to recalibration to ensure consistent measurements. Handle preload is factory set to 25-45 LBS. See How to Adjust Tool Preload (see Figure 5) to recalibrate.



Nest Color Code	Wire Range		“X” Dimension Conductor Crimp			Crimp Inspection Marking
	AWG	mm ²	Mean	Go	No Go	
Red	18 - 22	0.35 - 0.80	.114	.110	.122	o

Warranty

This tool is for electrical terminal crimping purposes only. This tool is made of the best quality materials. All vital components are long life tested. All tools are warranted to be free of manufacturing defects for a period of **30 days**. Should such a defect occur, we will repair or exchange the tool free of charge. This repair or exchange will not be applicable to altered, misused or damaged tools. This tool is designed for hand use only. Any clamping, fixturing, or use of handle extensions voids this warranty.

Hand held crimping tools are intended for low volume, prototyping, or repair requirements only.

Caution: Repetitive use of this tool should be

RHT 2050 Hand Crimp Tool

PARTS LIST

Item	Order No	Description	Quantity
	64001-1200	Hand Crimp Tool	(Fig. 6)
1	64000-0076	Repair Kit (Springs, Pins and E-Rings)	1
2	63810-0000	Handle	1
3	64007-0375	Locator Assembly	1
4	64001-1270	Tooling Kit	1
Tooling Kit Only			
5	64001-1202	Conductor Punch	1
6	64001-1201	Conductor Anvil	1
7	64001-1204	Insulation Punch	1
8	64001-1203	Insulation Anvil	1
9	N/A	4 mm Dia. by 5.0 mm Lg. Roll Pins	2**
10	N/A	#10-32 by 5/16" Lg. Cup Pt. Set Screw	1**

** The following purchased parts are available from an Industrial supply company such as MSC (1-800-645-7270).

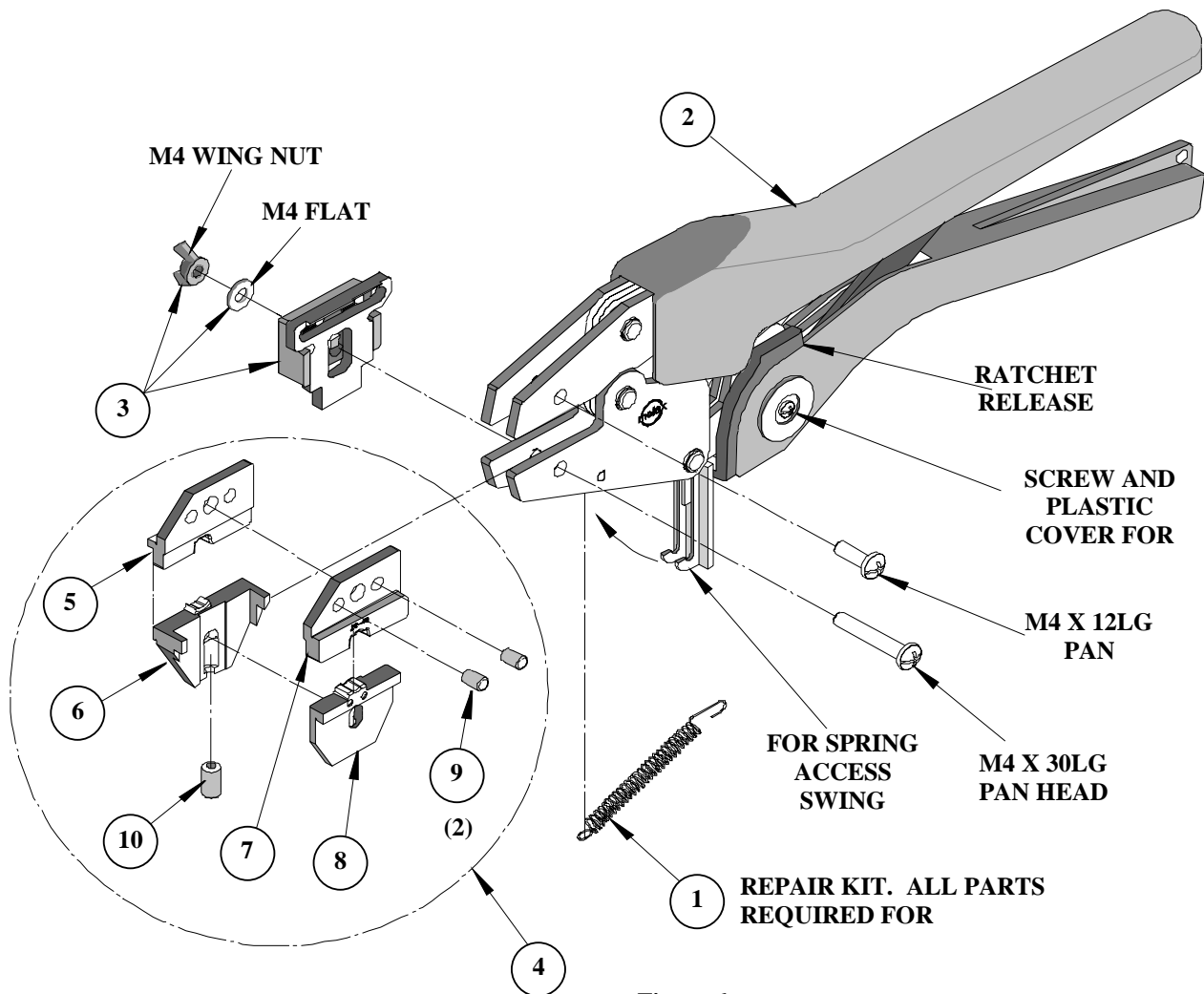
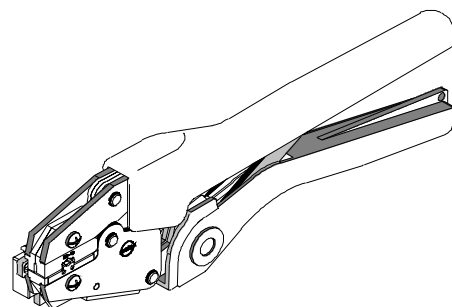

Figure 6

RHT 2050 Hand Crimp Tool



Certificate of Calibration

Tool Order Number _____

Tool Eng. Number _____

Tool Revision _____

Serial Number _____

Date of Manufacture _____

Handle Load Range at 1 inch from the Tips = _____

Actual = _____

Pin Gauge of Conductor Nest/Nests or Slug height if the nest is the "F" Crimp style.

Range Conductor Nest # 1 = _____ -- Actual = _____

Range Conductor Nest # 2 = _____ -- Actual = _____

Range Conductor Nest # 3 = _____ -- Actual = _____

Technician _____

Date of Calibration _____

Calibration should be done every 5,000 cycles or 3 months.

Tools should be lubricated during this operation.

Molex Application Tooling Group

1150 E. Diehl Road
Naperville, IL 60563
Tel: (630) 969-4550
Fax: (630) 505-0049