

## Excellent Integrated System Limited

Stocking Distributor

Click to view price, real time Inventory, Delivery & Lifecycle Information:

[M/A-Com Technology Solutions](#)

[MAMXSS0010TR-3000](#)

For any questions, you can email us directly:

[sales@integrated-circuit.com](mailto:sales@integrated-circuit.com)

# MAMXSS0010



## MMIC Medium Level Mixer 1700 - 2000 MHz

Rev. V3

### Features

- Low Conversion Loss
- Input Power @ 1 dB Compression: +21 dBm
- Typical Two-Tone IM Ratio:  $\geq 50$  dBc
- LO Drive Level: +11 to +23 dBm
- DC - 200 MHz IF Bandwidth
- Lead-Free SOIC-8 Package
- 100% Matte Tin Plating over Copper
- Halogen-Free "Green" Mold Compound
- 260°C Reflow Compatible
- RoHS\* Compliant Version of MD54-0003

### Description

M/A-COM's MAMXSS0010 is a passive mixer that achieves the performance of a double balanced diode mixer in a lead-free surface mount plastic SOIC-8 package. The MAMXSS0010 is ideally suited for use where high level RF signals and very wide dynamic range are required.

Typical applications include frequency up/down conversion, modulation, demodulation in systems such as base station receivers and transmitters for DCS1800, PCS and PHS applications.

The MAMXSS0010 uses FETs as mixing elements to achieve very wide dynamic range in a low cost plastic package. The mixer operates with LO drive levels of +11 dBm to +23 dBm. No DC bias is required.

M/A-COM's MAMXSS0010 is fabricated using a mature 1-micron GaAs process. The process features full IC passivation for increased performance and reliability.

### Functional Diagram

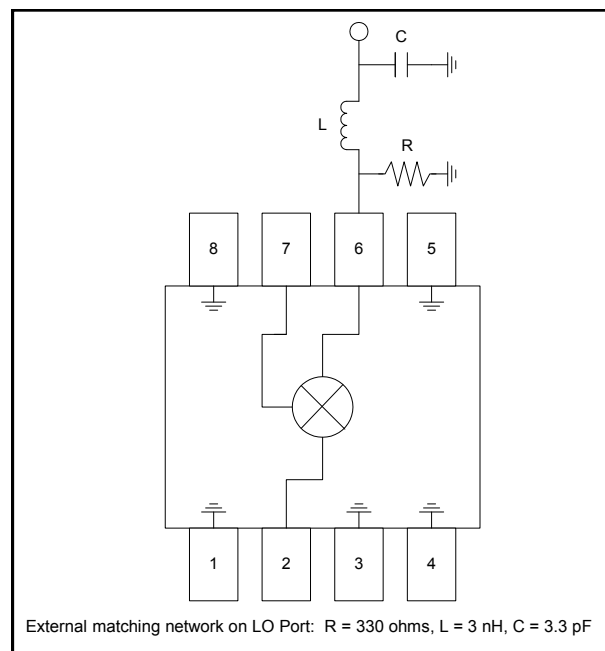

### Pin Configuration

Pin No.	Function	Pin No.	Function
1	Ground	5	Ground
2	RF Port	6	LO Port
3	Ground	7	IF Port
4	Ground	8	Ground

### Ordering Information

Part Number	Package
MAMXSS0010	Bulk Packaging
MAMXSS0010TR	1000 piece reel
MAMXSS0010SMB	Designer's Kit

1. Reference Application Note M513 for reel size information.

\* Restrictions on Hazardous Substances, European Union Directive 2002/95/EC.

# MAMXSS0010



## MMIC Medium Level Mixer 1700 - 2000 MHz

Rev. V3

### Electrical Specifications:

Test Conditions: RF = 1850 MHz (-10 dBm), LO = 1710 MHz (13 dBm), IF = 140 MHz, T<sub>A</sub> = +25°C

Parameter	Test Conditions	Units	Min	Typ	Max
Conversion Loss	—	dB	—	8.5	9.5
Isolation	LO to RF	dB	—	27	—
	LO to IF	dB	—	12	—
	RF to IF	dB	—	10	—
VSWR	LO Port	Ratio	—	2.5:1	—
	RF Port	Ratio	—	2.0:1	—
	IF Port	Ratio	—	2.0:1	—
Input 1 dB Compression	RF Freq. = 1800 MHz, LO = +13 dBm	dBm	—	+21	—
Two-Tone IM Ratio <sup>2</sup>	Two tones at -10 dBm each, Tone spacing 100 kHz, IF = 140 MHz	dBc	50	65	—

2. IMR vs RF drive level can be calculated by the formula:  $IMR = 50 - (1.5 \times P_{IN})$

### Absolute Maximum Ratings<sup>3,4</sup>

Parameter	Absolute Maximum
RF Input Power <sup>5</sup>	+22 dBm
LO Drive Power <sup>5</sup>	+23 dBm
Operating Temperature	-40°C to +85°C
Storage Temperature	-65°C to +150°C

- Exceeding any one or combination of these limits may cause permanent damage to this device.
- M/A-COM does not recommend sustained operation near these survivability limits.
- Total combined power for RF and LO ports should not exceed +23 dBm.

### Handling Procedures

Please observe the following precautions to avoid damage:

### Static Sensitivity

Gallium Arsenide Integrated Circuits are sensitive to electrostatic discharge (ESD) and can be damaged by static electricity. Proper ESD control techniques should be used when handling these devices.

### Spurious Table

Harmonic of LO	4x	17 6.9	48.2 47.2	62.3 61.1	71.7 61.7	73.4 63.4
	3x	10.3 0.3	28.9 28.9	63.0 61.3	71.3 63.5	70.6 61.6
	2x	-8.8 -18.8	-25.7 25.9	52.1 61.3	71.5 61.5	72.1 62.1
	1x	-13.1 -23.1	0 0	67.5 61.1	71.3 61.9	72.6 62.6
	0x	X X	2.1 2.1	56.8 61.7	72.3 62.3	69.3 59.8
	Harmonic of RF					
	0x	1x	2x	3x	4x	

The spurious table shows the spurious signals resulting from the mixing of the RF and LO input signals, assuming down conversion. Mixing products are indicated by the number of dB below the conversion loss. The lower frequency mixing term is shown for two different RF input levels. The top number is for an RF input power of -5 dBm, the lower number is for -15 dBm.

$|mF_{RF} - nF_{LO}|$ , RF = -5 dBm  
 $|mF_{RF} - nF_{LO}|$ , RF = -15 dBm  
 RF Frequency = 1850 MHz  
 LO Frequency = 1710 MHz

# MAMXSS0010



## MMIC Medium Level Mixer 1700 - 2000 MHz

Rev. V3

### Typical Performance Curves

#### Conversion Loss

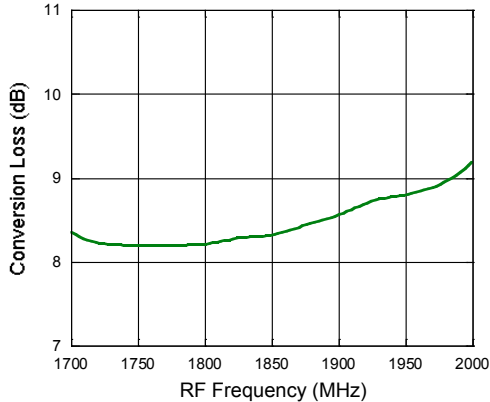

#### Isolation

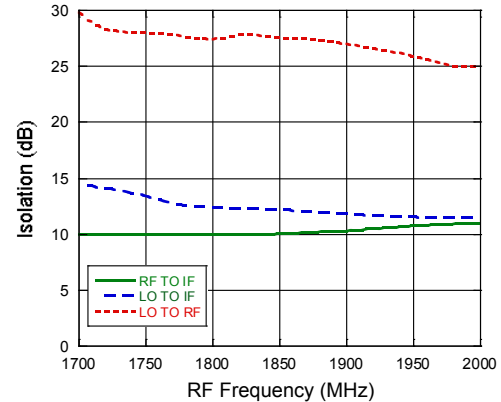

#### Input P1dB

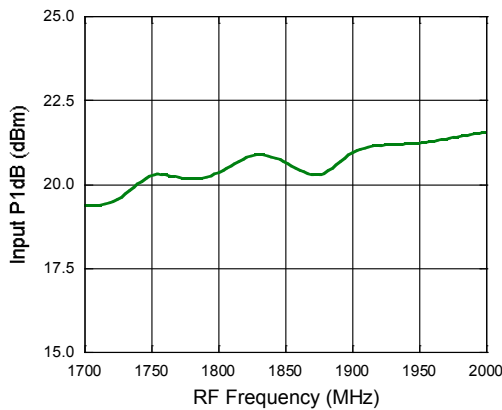

#### RF, LO and IF VSWR

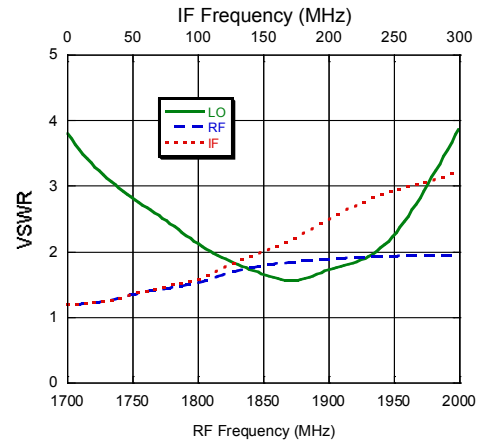

### Lead-Free SOIC-8†

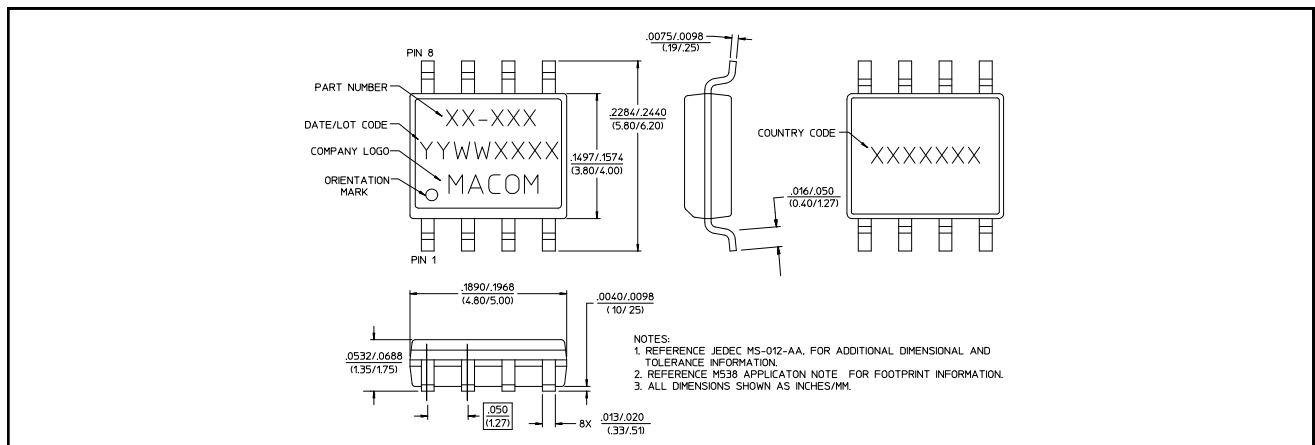

† Reference Application Note M538 for lead-free solder reflow recommendations.

# MAMXSS0010



**MMIC Medium Level Mixer**  
**1700 - 2000 MHz**

Rev. V3

M/A-COM Technology Solutions Inc. All rights reserved.

Information in this document is provided in connection with M/A-COM Technology Solutions Inc ("MACOM") products. These materials are provided by MACOM as a service to its customers and may be used for informational purposes only. Except as provided in MACOM's Terms and Conditions of Sale for such products or in any separate agreement related to this document, MACOM assumes no liability whatsoever. MACOM assumes no responsibility for errors or omissions in these materials. MACOM may make changes to specifications and product descriptions at any time, without notice. MACOM makes no commitment to update the information and shall have no responsibility whatsoever for conflicts or incompatibilities arising from future changes to its specifications and product descriptions. No license, express or implied, by estoppels or otherwise, to any intellectual property rights is granted by this document.

THESE MATERIALS ARE PROVIDED "AS IS" WITHOUT WARRANTY OF ANY KIND, EITHER EXPRESS OR IMPLIED, RELATING TO SALE AND/OR USE OF MACOM PRODUCTS INCLUDING LIABILITY OR WARRANTIES RELATING TO FITNESS FOR A PARTICULAR PURPOSE, CONSEQUENTIAL OR INCIDENTAL DAMAGES, MERCHANTABILITY, OR INFRINGEMENT OF ANY PATENT, COPYRIGHT OR OTHER INTELLECTUAL PROPERTY RIGHT. MACOM FURTHER DOES NOT WARRANT THE ACCURACY OR COMPLETENESS OF THE INFORMATION, TEXT, GRAPHICS OR OTHER ITEMS CONTAINED WITHIN THESE MATERIALS. MACOM SHALL NOT BE LIABLE FOR ANY SPECIAL, INDIRECT, INCIDENTAL, OR CONSEQUENTIAL DAMAGES, INCLUDING WITHOUT LIMITATION, LOST REVENUES OR LOST PROFITS, WHICH MAY RESULT FROM THE USE OF THESE MATERIALS.

MACOM products are not intended for use in medical, lifesaving or life sustaining applications. MACOM customers using or selling MACOM products for use in such applications do so at their own risk and agree to fully indemnify MACOM for any damages resulting from such improper use or sale.