

Excellent Integrated System Limited

Stocking Distributor

Click to view price, real time Inventory, Delivery & Lifecycle Information:

[Maxim Integrated](#)
[DS1836C-10](#)

For any questions, you can email us directly:

sales@integrated-circuit.com



DS1836/A/B/C/D 3.3V/5V MicroManager

www.maxim-ic.com

FEATURES

- 5V or 3.3V power-on reset
- True 3V operation power switch
- Switches to battery at 3.8V (2.6V for 3.3V versions)
- Excellent for systems designed to operate with dual power supplies
- Asserts resets during power transients
- Maintains reset for 350ms after V_{CC} returns to an in-tolerance condition
- Reduces need for discrete components
- Precision temperature-compensated voltage reference and voltage sensor
- 8-pin DIP or space saving 8-pin SO surface mount available
- CMOS reset output for low current operation
- Operating temperature of -40°C to $+85^{\circ}\text{C}$
- Perfect for PIC microprocessor applications

PIN ASSIGNMENT

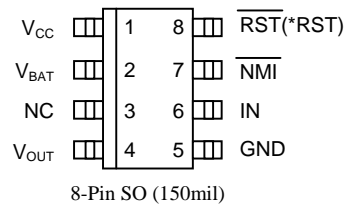
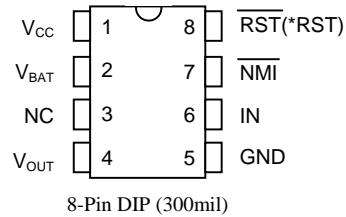

DS1836A/C (*DS1836B/D)

PIN DESCRIPTION

V_{CC}	- Power Supply Input
V_{BAT}	- Battery Supply Input
NC	- No Connect
V_{OUT}	- Power Supply Output
GND	- Ground
IN	- Sense Input
$\overline{\text{NMI}}$	- Non-maskable Interrupt
$\overline{\text{RST}}$ (*RST)	- Reset Output

DESCRIPTION

The DS1836 MicroManager performs three vital system functions. First, a precision temperature-compensated reference and comparator circuit monitor the status of the voltage on V_{CC} and when an out-of-tolerance condition is detected, an internal power-fail signal is generated that forces the reset active. If V_{CC} continues to degrade, it switches to the battery supply when V_{CC} drops below 3.8V (2.6V for 3.3V versions). When V_{CC} exceeds 3.9V (2.8V for 3.3V versions); V_{OUT} will again be supplied from V_{CC} . Reset will remain active for 350 ms after V_{CC} returns to an in-tolerance condition.

Lastly, the DS1836 supports a sense input that sends a non-maskable interrupt whenever the sense input drops below 1.25V.

OPERATION

Power Monitor

The DS1836 provides the functions of detecting out-of-tolerance conditions on a 3.3V or 5V power supply and warning a processor-based system of impending power failure. When V_{CC} is detected as out of tolerance the RST will be forced active. When V_{CC} returns to a valid state the RST will remain active for about 350ms and then return to an inactive state until the next V_{CC} out-of-tolerance condition.

On power-up reset is kept active for approximately 350ms after the power supply input has reached the selected tolerance. This allows the power supply and system power to stabilize before RST is released.

Power Switch (DS1836A & B)

The DS1836 switches the V_{OUT} output between V_{CC} and V_{BAT} . On the initial power-up, V_{OUT} draws current from the V_{BAT} input until V_{CC} exceeds 3.9V. When V_{CC} exceeds 3.9V V_{OUT} switches from V_{BAT} to V_{CC} and will not switch back to V_{BAT} until V_{CC} drops below 3.8V. When V_{CC} is below 3.8V, power will be drawn from the supply with the highest voltage: either V_{CC} or V_{BAT} .

Power Switch (DS1836C & D)

The DS1836 switches the V_{OUT} output between V_{CC} and V_{BAT} . On the initial power up, V_{OUT} draws current from the V_{BAT} input until V_{CC} exceeds 2.8V. When V_{CC} exceeds 2.8V V_{OUT} switches from V_{BAT} to V_{CC} and will not switch back to V_{BAT} until V_{CC} drops below 2.6V. When V_{CC} is below 2.6V, power will be drawn from the supply with the highest voltage either V_{CC} or V_{BAT} .

BLOCK DIAGRAM Figure 1

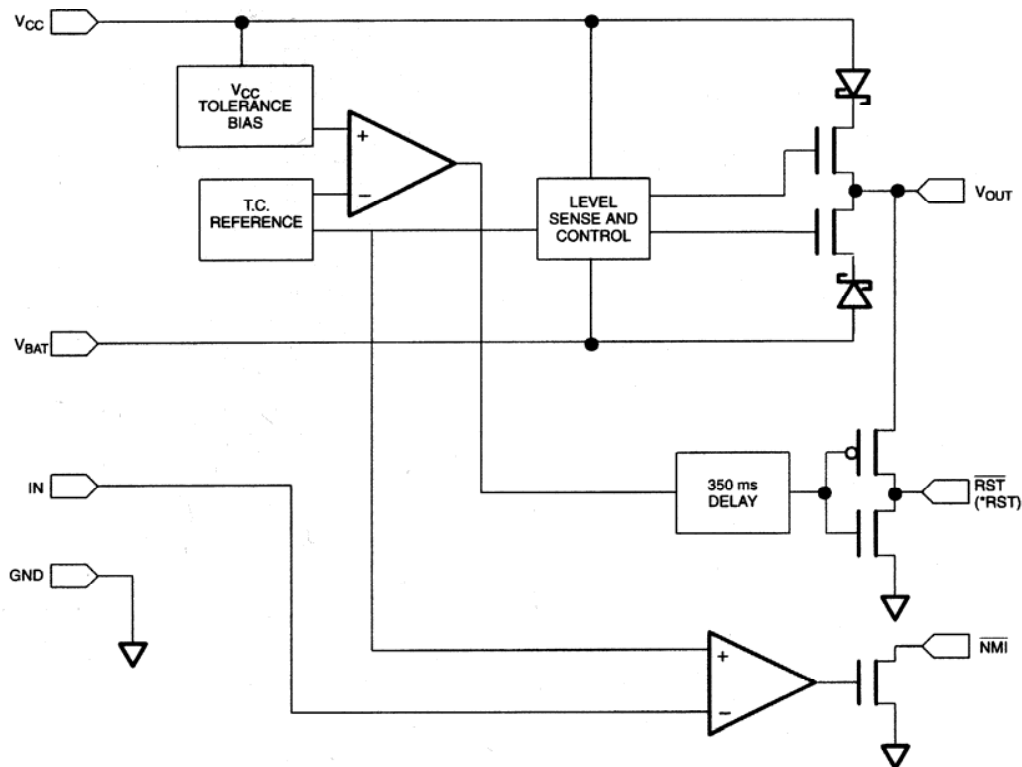

* DS1836B and DS1836D

Non-Maskable Interrupt

The DS1836 generates a non-maskable interrupt ($\overline{\text{NMI}}$) for early warning of a power failure. A precision comparator monitors the voltage level at the IN pin relative to an on-chip reference generated by an internal band gap. The IN pin is a high impedance input allowing for a user-defined sense point. An external resistor voltage divider network (Figure 3) is used to interface with high voltage signals. This sense point may be derived from a regulated supply or from a higher DC voltage level closer to the main system power input. Since the IN trip point V_{TP} is 1.25V, the proper values for R1 and R2 can be determined by the equation as shown in Figure 3. Proper operation of the DS1836 requires that the maximum voltage at the IN pin be limited to the active supply (V_{CC} or V_{BAT}). Therefore, the maximum allowable voltage at the supply being monitored (V_{MAX}) can also be derived as shown in Figure 3. A simple approach to solving the equation is to select a value for R2 high enough to keep power consumption low and solve for R1. The flexibility of the IN input pin allows for detection of power loss at the earliest point in a power supply system, maximizing the amount of time for system shutdown between $\overline{\text{NMI}}$ and $\overline{\text{RST}}$ (or $\overline{\text{RST}}$).

A pull-up resistor is required for proper operation of the $\overline{\text{NMI}}$ open-drain output. A 10k Ω resistor would be a typical value for the pull-up resistor.

TYPICAL APPLICATION Figure 2

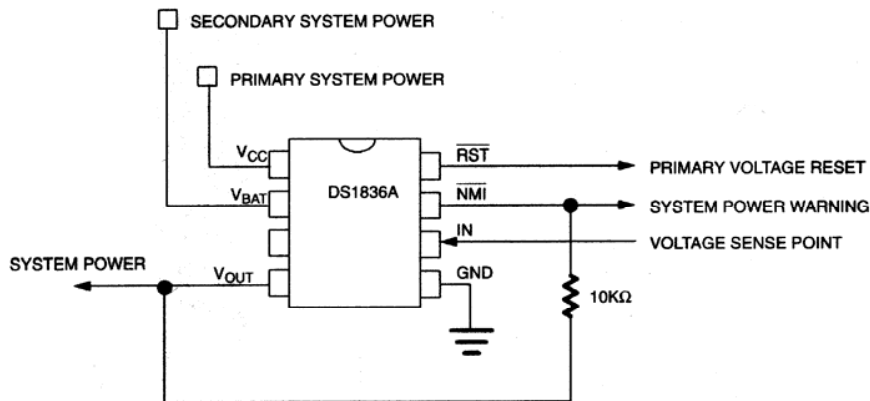

NON-MASKABLE INTERRUPT CIRCUIT EXAMPLE Figure 3

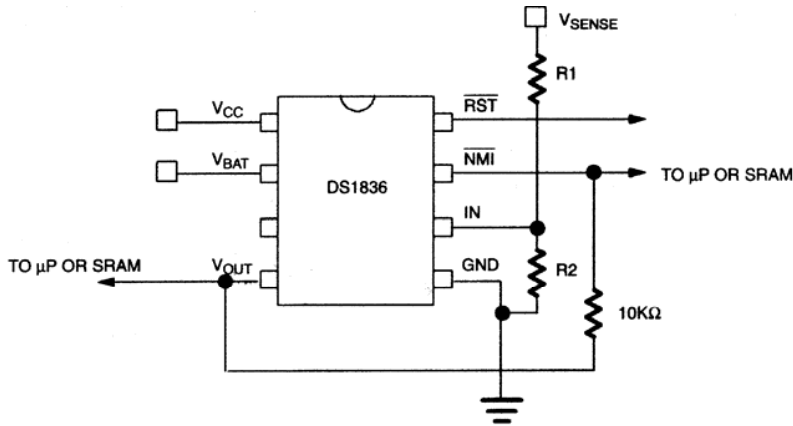

$$V_{SENSE} = \frac{R1 + R2}{R2} \times 1.25$$

Example: $V_{SENSE} = 4.50V$ at the trip point
 $100k\Omega = R2$

Therefore: $4.5 = \frac{R1 + 100k}{100k} \times 1.25$ $R1 = 260k\Omega$

TIMING DIAGRAM: NON-MASKABLE INTERRUPT Figure 4

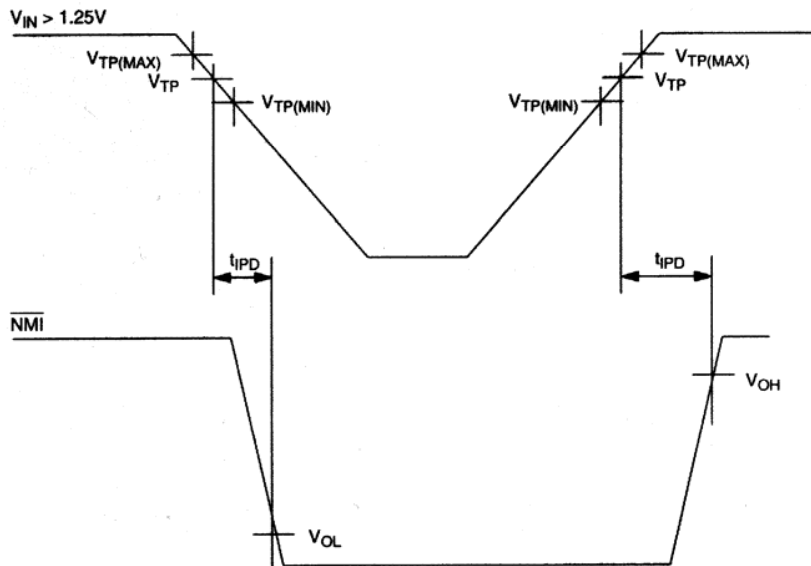

OUTPUT VALID CONDITIONS

The DS1836 can maintain valid outputs as long as one input remains above 1.2V. However, the $\overline{\text{RST}}$ outputs on the DS1836A (or C) use a push-pull output structure which can maintain a valid output below 1.2V on an input. To sink current below 1.2V a resistor can be connected from $\overline{\text{RST}}$ to GND (see Figure 5). This arrangement will maintain a valid value on the $\overline{\text{RST}}$ outputs even if all supply inputs are at 0V. During conditions when the $\overline{\text{RST}}$ is in the inactive or high state this arrangement will draw current through the pull down resistor. A value of about 100 k Ω should be adequate to maintain a valid condition.

The DS1836 $\overline{\text{NMI}}$ output requires a pull-up resistor on the output to maintain a valid output. The value of the resistor is not critical in most cases but must be set low enough to pull the output to a high state. A common value used is 10k Ω s (see Figure 3).

APPLICATION DIAGRAM:

$\overline{\text{RST}}$ VALID TO 0V V_{CC} ON THE DS1836A OR DS1836C Figure 5

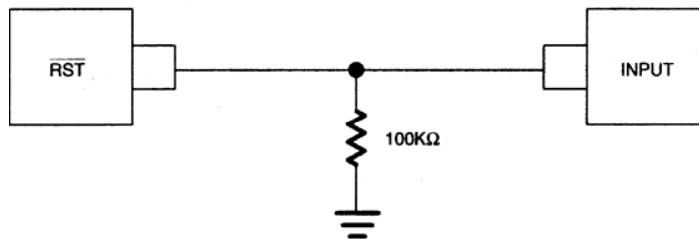

TIMING DIAGRAM: POWER-UP Figure 6

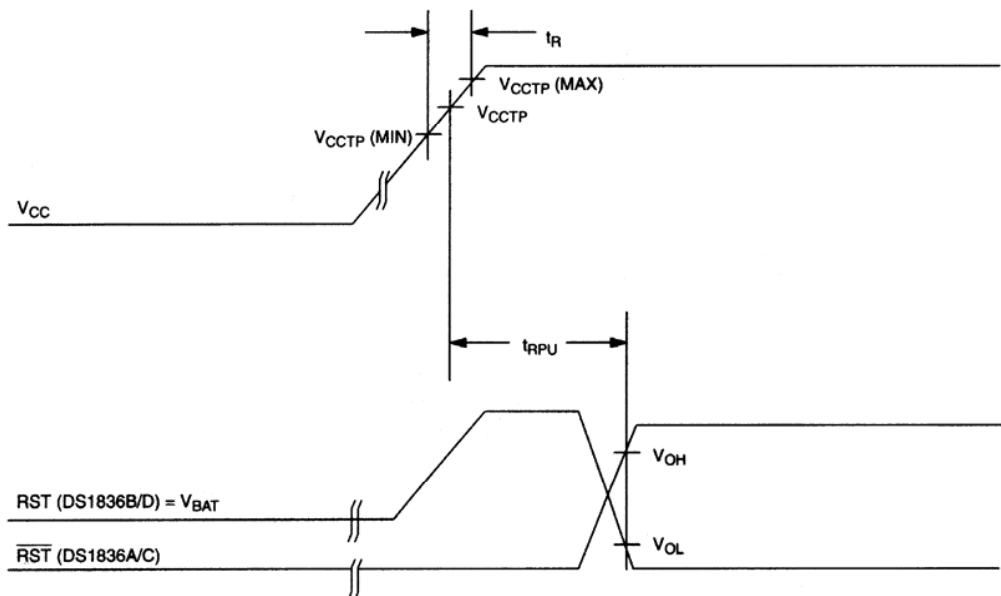

TIMING DIAGRAM: POWER-DOWN Figure 7

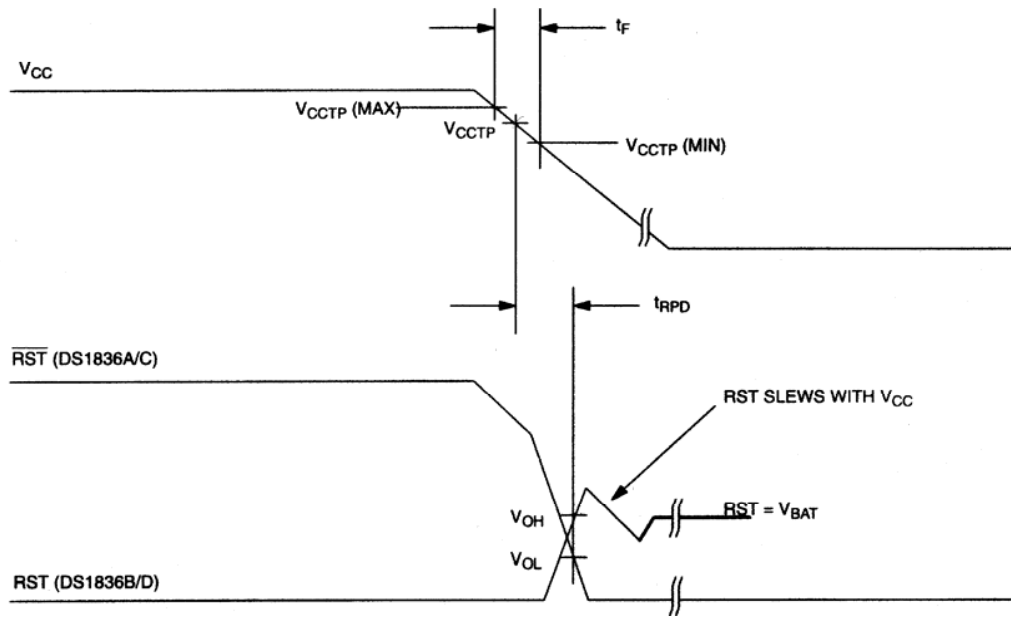

TIMING DIAGRAM: POWER SWITCH Figure 8

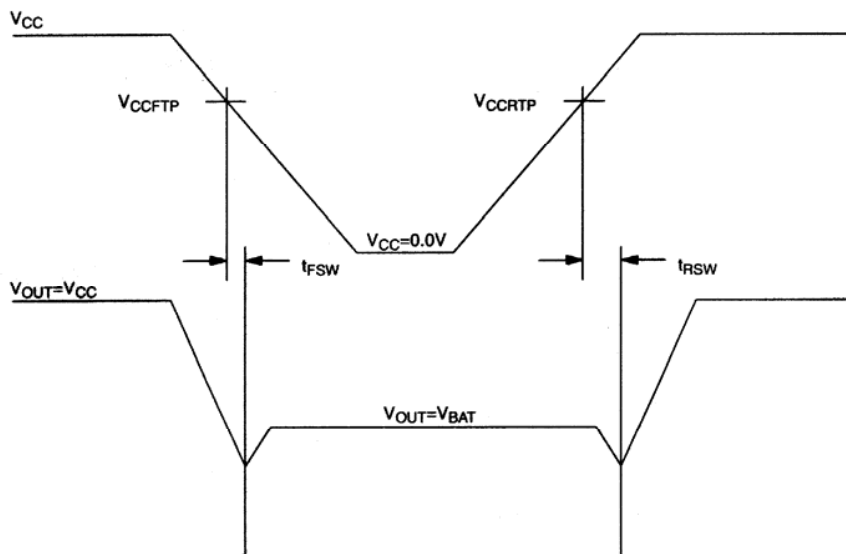

ABSOLUTE MAXIMUM RATINGS*

Voltage on V_{CC} or V_{BAT} Pin Relative to Ground	-0.5V to +7.0V
Voltage on any I/O Pin Relative to Ground**	-0.5V to $V_{OUT} + 0.5V$
Operating Temperature Range	-40°C to +85°C
Storage Temperature Range	-55°C to +125°C
Soldering Temperature	260°C for 10 seconds

* This is a stress rating only and functional operation of the device at these or any other conditions above those indicated in the operation sections of this specification is not implied. Exposure to absolute maximum rating conditions for extended periods of time may affect reliability.

**The voltage input on IN can exceed V_{CC}/V_{BAT} if the input current is less than 10mA.

RECOMMENDED DC OPERATING CONDITIONS

(-40°C to +85°C)

PARAMETER	SYMBOL	MIN	TYP	MAX	UNITS	NOTES
Supply Voltage	V_{CC}	1.2		5.5	V	1
Secondary Supply Voltage	V_{BAT}	1.2		5.5	V	1

DC ELECTRICAL CHARACTERISTICS (-40°C to +85°C; $V_{CC} = 1.2V$ to $5.5V$)

PARAMETER	SYMBOL	MIN	TYP	MAX	UNITS	NOTES
Output Voltage @ -500 μ A	V_{OH}	V_{CC} -0.5	V_{CC} -0.1		V	1
Input Leakage	I_{IL}	-1.0		+1.0	μ A	2
Output Current @ 2.4V	I_{OH}		350		μ A	3
Output Current @ 0.4V	I_{OL}	+10			mA	3
Operating Current @ * 5.5 V_{IN}	I_{CC}		35	55	μ A	4
Operating Current @ * 3.6 V_{IN}	I_{CC}		30	50	μ A	5
Supply Output Current	I_{CC01}			100	mA	6
Supply Output Current	I_{CC02}			100	mA	7
Supply Output Voltage (V_{CC})	V_{OUT}	V_{CC} -0.5	V_{CC} -0.3		V	1, 8
Supply Output Voltage (V_{BAT})	V_{OUT}	V_{BAT} -0.5	V_{BAT} -0.3		V	1, 9
RST V_{CC} Trip Point DS1836A(or B)-05	V_{CCCTP}	4.50	4.63	4.75	V	1
RST V_{CC} Trip Point DS1836A(or B)-10	V_{CCCTP}	4.25	4.37	4.50	V	1
RST V_{CC} Trip Point DS1836C(or D)-10	V_{CCCTP}	2.80	2.88	2.97	V	1
RST V_{CC} Trip Point DS1836C(or D)-20	V_{CCCTP}	2.67	2.72	2.80	V	1
Power Supply Trip Points (V_{CC} to V_{BAT}) DS1836 C or D	V_{CCFTP}	2.60	2.65	2.70	V	1, 10
Power Supply Trip Points (V_{BAT} to V_{CC}) DS1836 C or D	V_{CCRTP}	2.70	2.75	2.80	V	1, 10
V_{BAT} Leakage Current	I_{CC03}			0.10	μ A	11
Power Supply Trip Points (V_{CC} to V_{BAT}) DS1836 A or B	V_{CCFTP}	3.80	3.85	3.9	V	1, 10
Power Supply Trip Points (V_{BAT} to V_{CC}) DS1836 A or B	V_{CCRTP}	3.90	3.95	4.0	V	1, 10
IN Input Trip Point	V_{TP}	1.15	1.25	1.35	V	1
Output Capacitance	C_{OUT}			10	pF	

AC ELECTRICAL CHARACTERISTICS (-40°C to +85°C; $V_{CC} = 1.2V$ to $5.5V$)

PARAMETER	SYMBOL	MIN	TYP	MAX	UNITS	NOTES
V_{TP} to \overline{NMI} Delay	t_{IPD}			1	μs	
Reset Active Time	t_{RST}	200	350	500	ms	
V_{CC} Slew Rate ($V_{INTP(MIN)}$ to $V_{INTP(MAX)}$)	t_R	0			ns	
V_{CC} Detect to \overline{RST}	t_{RPU}	200	350	500	ms	12
V_{CC} Slew Rate ($V_{INTP(MAX)}$ to $V_{INTP(MIN)}$)	t_F	300			μs	
V_{CC} Detect to \overline{RST}	t_{RPD}		2	10	μs	
V_{CC} to V_{BAT} (V_{CC} falling through 2.6V)	t_{FSW}		1		μs	
V_{BAT} to V_{CC} (V_{CC} rising through 2.8V)	t_{RSW}		1		μs	

NOTES:

- 1) All voltages are referenced to ground.
- 2) Measured with outputs open and inputs at V_{CC} or GND.
- 3) Measured with outputs open and V_{CC} or $V_{BAT} < 2.7V$.
- 4) Measured with outputs open and both V_{CC} and $V_{BAT} < 5.5V$.
- 5) Measured with outputs open and both V_{CC} and $V_{BAT} < 3.6V$.
- 6) $V_{OUT} = V_{CC} - 0.3V$.
- 7) $V_{OUT} = V_{BAT} - 0.3V$.
- 8) $V_{CC} < 2.7V$.
- 9) $V_{BAT} < 2.0V$ and $V_{CC} < 1.9V$.
- 10) V_{CCFTP} is offset by approximately 0.1V from V_{CCRTP} .
- 11) V_{BAT} in the off state and $V_{BAT} < V_{CC}$ ($V_{BAT} > V_{CC}$ and V_{BAT} in the off state 1.5 μA maximum).
- 12) $t_R = 5\mu s$ with one supply $< 2.5V$.

REVISION HISTORY

Pages changed at Rev 1: 1, 9, 10