

Excellent Integrated System Limited

Stocking Distributor

Click to view price, real time Inventory, Delivery & Lifecycle Information:

[XP Power](#)
[ISJ1205A](#)

For any questions, you can email us directly:

sales@integrated-circuit.com

1 Watt

ISJ Series



- Single Output
- Ultra Slim SMD Package
- Industry Standard Pinout
- 1500 VDC Isolation
- MTBF >3.5 MHrs
- -40 °C to +85 °C Operation
- 3 Year Warranty

Specification

Input

- Input Voltage Range • Nominal ±10%
- Input Reverse Voltage Protection • None

Output

- Output Voltage • See table
- Minimum Load • 10%
- Line Regulation • 1.2%/1% Δ Vin
- Load Regulation • 7.5% max for 10-100% load change
- Setpoint Accuracy • 100-110% of nominal at 10% load
- Ripple & Noise • 75 mV pk-pk 20 MHz bandwidth
- Temperature Coefficient • 0.03%/°C
- Short Circuit Protection • Continuous

General

- Efficiency • See table
- Isolation Voltage • 1500 VDC minimum⁽¹⁾
- Isolation Resistance • 10⁹ Ω
- Isolation Capacitance • 25 pF typical
- Switching Frequency • 100 kHz typical at nominal input, full load
- MTBF • >3.5 MHrs to MIL-HDBK-217F at 25 °C, GB

Environmental

- Operating Temperature • -40 °C to +85 °C
- Storage Temperature • -55 °C to +125 °C
- Case Temperature • 105 °C max
- Cooling • Convection-cooled
- Lead Temperature • 250 °C, 0.06 in (1.5 mm) from case, 10 s

Input Voltage	Output Voltage	Output Current	Efficiency (typ)	Model Number
5 VDC	5.0 V	200 mA	74%	ISJ0505A ⁽¹⁾
	12.0 V	83 mA	77%	ISJ0512A
	15.0 V	67 mA	76%	ISJ0515A
12 VDC	5.0 V	200 mA	73%	ISJ1205A

Notes

1. ISJ0505A available with 3000 VDC isolation, add suffix '-H' to part number.

Mechanical Details

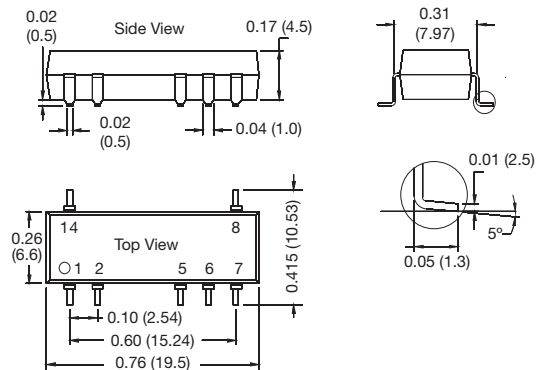

Recommended footprint

Top view grid: 0.1 x 0.1 in (2.54 x 2.54 mm)

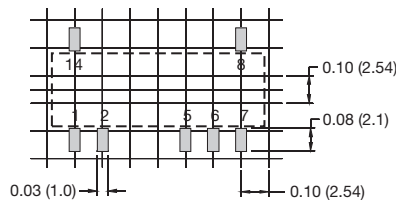

Pin	Function
1	Vin
2	GND
5	0 V
6	+Vout
7	N.C.
8	N.C.
14	N.C.

N.C. Not connected

Notes

1. All dimensions in inches (mm)
2. Tolerance: ±0.010 (±0.25)
3. Weight: 0.003 lbs (1.4 g)
4. Pin tolerance: ±0.004 (±0.10 mm)