

Excellent Integrated System Limited

Stocking Distributor

Click to view price, real time Inventory, Delivery & Lifecycle Information:

[Panduit](#)
[PN12-10HDRX-L](#)

For any questions, you can email us directly:
sales@integrated-circuit.com

THIS COPY IS PROVIDED ON A RESTRICTED BASIS AND IS NOT TO BE USED IN ANY WAY DETRIMENTAL TO THE INTERESTS OF PANDUIT CORP.

PANDUIT PART NUMBER	STUD SIZE	DIMENSIONS in.				
		A ±.020	W ±.010	C ±.015	M ±.020	H ±.010
PN12-6HDRX	#6	1.07 (27.18)	.31 (7.87)	.35 (8.89)	.91 (23.11)	.15 (3.81)
PN12-8HDRX	#8	1.07 (27.18)	.31 (7.87)	.35 (8.89)	.91 (23.11)	.17 (4.32)
PN12-10HDRX	#10	1.13 (28.70)	.37 (9.40)	.33 (8.38)	.94 (23.88)	.20 (5.08)
PN12-14HDRX	1/4"	1.27 (32.26)	.52 (13.21)	.42 (10.67)	1.01 (25.65)	.27 (6.86)
PN12-56HDRX	5/16"	1.27 (32.26)	.52 (13.21)	.42 (10.67)	1.01 (25.65)	.34 (8.64)
PN12-38HDRX	3/8"	1.35 (34.29)	.58 (14.73)	.46 (11.68)	1.06 (26.92)	.40 (10.16)

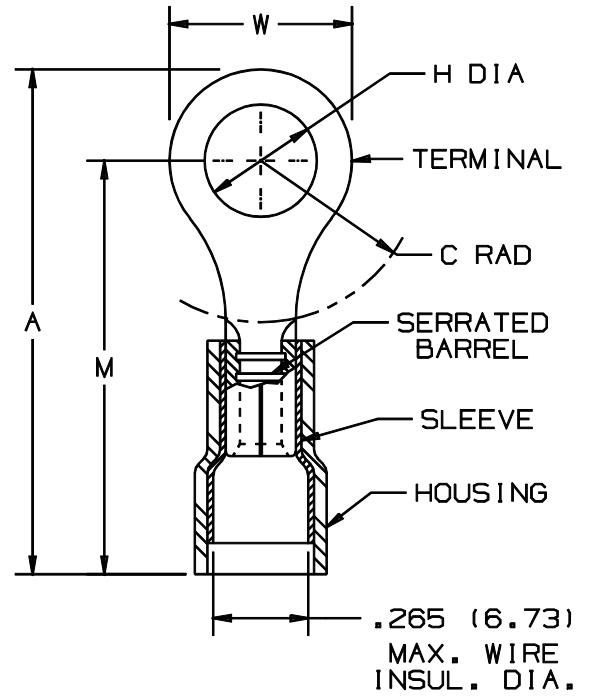

NOTES:

- UL LISTED AND CSA CERTIFIED FOR:
 - A. 300V. MAX. VOLTAGE RATING
 - B. #16-12 AWG STRANDED COPPER WIRE
 - C. 221° F (105° C) MAX. TEMP. RATING
- MATERIAL:
 - A. STAMPING - .05" (1.27) THK COPPER, TIN PLATED
 - B. HOUSING - NYLON, YELLOW
 - C. SLEEVE - BRASS, TIN PLATED
- PACKAGE QTY: STD. PKG. NOT AVAILABLE
BULK PKG. 500
- DIMENSIONS IN BRACKETS ARE IN MILLIMETERS
- INSTALLATION TOOLS:
 - A. UL LISTED AND CSA CERTIFIED: CT-550
 - B. PANDUIT APPROVED: CT-460



LISTED
587H
E52164



CERTIFIED
LR31212

A41284_02

								PANDUIT CORP. TINLEY PARK, ILLINOIS				
02	1/01	RM		FILESPEC WAS A41284A::1:L1				#16-12 BARREL NYLON INSULATED HEAVY DUTY RING TONGUE, .265 (6.73) MAX. WIRE INSULATION DIAMETER				
1	7-88	DW		REDRAWN WITH REVISIONS								
REV	DATE	BY	CHK	DESCRIPTION	QA	CUST	PM	APP	DRAWN BY: DAW	CHK'D	SCALE: NONE	DRAWING NO.: A41284