

Excellent Integrated System Limited

Stocking Distributor

Click to view price, real time Inventory, Delivery & Lifecycle Information:

[Molex Connector Corporation](#)
[0761553808](#)

For any questions, you can email us directly:

sales@integrated-circuit.com

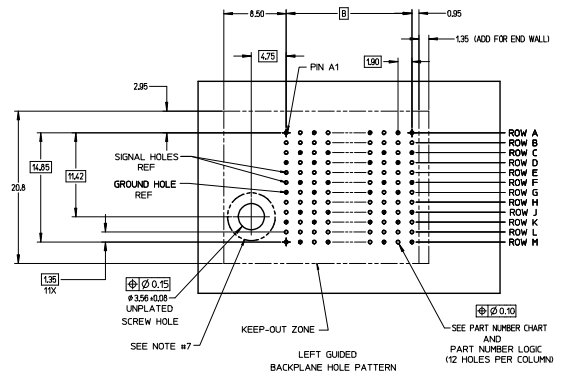
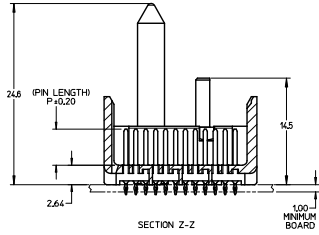
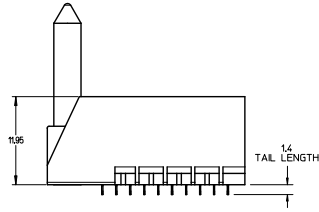
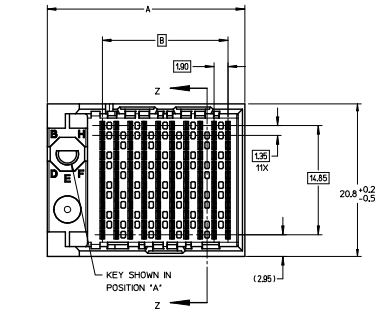

- NOTES:
- MATERIALS: HOUSING - LIQUID CRYSTAL POLYMER (LCP) GLASS-FILLED, UL94V-0
TERMINALS - HIGH PERFORMANCE COPPER ALLOY
Pd-Ni IN CONTACT AREA. SELECTIVE TIN ON PCB TAILS. NICKEL OVERALL.
 - FINISH 5 MICRONCH MINIMUM GOLD FLASH OVER 20 MICRONCH MINIMUM Pd-Ni IN CONTACT AREA. SELECTIVE TIN ON PCB TAILS. NICKEL OVERALL.
 - REFER TO MOLEX PRODUCT SPECIFICATION PS-76060-999 FOR PERFORMANCE SPECIFICATIONS AND ADDITIONAL PCB INFORMATION.
 - THIS PART CONFORMS TO CLASS B REQUIREMENTS OF MOLEX COSMETIC SPEC PS-45499-002.
 - PACKAGE PER PK-70873-757.
 - SEE SHEETS 2 & 3 FOR PART NUMBERS AND BOARD RELATIONSHIPS.
 - FOR GROUNDED GUIDE PINS USE DIA. 3.56 +/-0.08 (PTH) DIA. 3.66 (DRILL) AND DIA. 6.5 (PAD).
 - MATES WITH IMPACT DC SERIES NO. 76160.
 - KEEP OUT ZONE FOR BP HOUSING LENGTH INCLUDES AN ADDITIONAL 1.0MM TO ACCOMMODATE FOR SPACE REQUIRED BY DC FRONT HOUSING.
 - REFER TO MOLEX PCB ROUTING GUIDE AS-76060-990 FOR ANTI PAD AND ROUTING RECOMMENDATIONS.
 - CONNECTORS SUPPLIED WITH A 2-56 UNC-2A SCREW.
 - THESE DIMENSIONS REPRESENT THE AREA NEEDED TO ACCOMMODATE CONNECTOR INSERTION AND REPAIR ON THE PC BOARD, THIS IS REFERRED TO AS THE "CONNECTOR KEEP OUT ZONE" AND DOES NOT REPRESENT THE ACTUAL PERIMETER OF THE CONNECTOR, WHEN LAYING OUT THE PC BOARD FOR CONNECTORS STACKED TOGETHER, USE A 1.9mm PROGRESSION.

Pd-Ni
PLATING

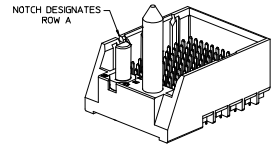

INITIAL RELEASE ECS INC. (EPT/04-2332) DRN/SVANG01 2015/12/08 CHK/OMW/LE 2015/12/08 APPRO/SML/LE 2015/12/17 REV	QUALITY SYMBOLS	GENERAL TOLERANCES (UNLESS SPECIFIED):	DIMENSION STYLE	SCALE	DESIGN UNITS	THIRD ANGLE PROJECTION
	$\nabla=0$ 4 PLACES \pm --- \pm --- $\nabla=0$ 3 PLACES \pm --- \pm --- $\nabla=0$ 2 PLACES ± 0.13 \pm --- $\nabla=0$ 1 PLACE ± 0.25 \pm --- $\nabla=0$ 0 PLACE \pm --- \pm ---	mm INCH	MM ONLY	4:1	METRIC	THIRD ANGLE PROJECTION
		ANGULAR $\pm 1/2^\circ$	DRAWN BY	DATE	TITLE	
		DRAFT WHERE APPLICABLE MUST REMAIN WITHIN DIMENSIONS	SVANG01	2015/12/08	IMPACT 4 PAIR HEADER LEFT GUIDED PDNI ASSEMBLY SALES DRAWING	
			CHECKED BY	DATE		
			MWOLFE	2015/12/08		
			APPROVED BY	DATE		
			SML/LE	2015/12/17		
			MATERIAL NO.	DOCUMENT NO.	SHEET NO.	
			SEE TABLE	RSD-173428-002	1 OF 3	
			THIS DRAWING CONTAINS INFORMATION THAT IS PROPRIETARY TO MOLEX INCORPORATED AND SHOULD NOT BE USED WITHOUT WRITTEN PERMISSION			

PART NUMBER TABLE

MATERIAL NUMBER	# OF COLUMNS	# OF DIFF PAIR	DIM 'A'	DIM 'B'	GUIDE LEFT END WALL OPTION
173428- *3**	6	24	19.3	9.50	
173428- *8**	8	32	23.1	13.30	
173428- *1**	10	40	26.9	17.10	
173428- *6**	16	64	38.3	28.50	

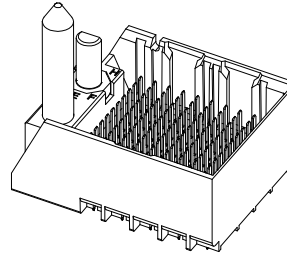

GUIDE LEFT
END WALL
OPTION

MATERIAL NUMBER	# OF COLUMNS	# OF DIFF PAIR	DIM 'A'	DIM 'B'	GUIDE LEFT OPEN WALL OPTION
173428- *3**	6	24	17.9	9.50	
173428- *8**	8	32	21.7	13.30	
173428- *1**	10	40	25.5	17.10	
173428- *6**	16	64	36.9	28.50	

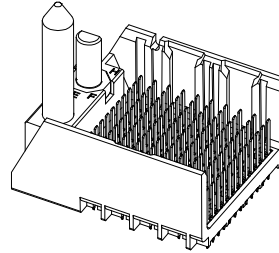

GUIDE LEFT
OPEN WALL
OPTION

PART NUMBER LOGIC

173428-****

- MODULE TYPE
 3 = GUIDE LEFT, TIN
 7 = GUIDE LEFT END WALL, TIN
- # OF COLUMNS
 1 = 10 COL
 3 = 6 COL
 6 = 16 COL
 8 = 8 COL
- PIN LENGTH (P)
 3 = 4.50 (SHORT COMPLIANT, 0.46±0.05 PTH)
 4 = 4.90 (SHORT COMPLIANT, 0.46±0.05 PTH)
 5 = 5.50 (SHORT COMPLIANT, 0.46±0.05 PTH)
 6 = 4.50 (MICRO COMPLIANT, 0.39±0.05 PTH)
 7 = 4.90 (MICRO COMPLIANT, 0.39±0.05 PTH)
 8 = 5.50 (MICRO COMPLIANT, 0.39±0.05 PTH)
- KEY ORIENTATION
 0 = NO KEY
 1 = A
 2 = B
 3 = C
 4 = D
 5 = E
 6 = F
 7 = G
 8 = H

SEE SHEET 1 EC NO: UCP2016-2332 DRWNSVANG01 2015/12/08 CHKDWOLFE 2015/12/08 APPRSMILLER 2015/12/17 DESCRIPTION REV A	QUALITY SYMBOLS	GENERAL TOLERANCES (UNLESS SPECIFIED)	DIMENSION STYLE MM ONLY	SCALE 3:1	DESIGN UNITS METRIC	THIRD ANGLE PROJECTION	
	$\nabla=0$ $\nabla=0$ $\nabla=0$	4 PLACES ± --- ± --- 3 PLACES ± --- ± --- 2 PLACES ± 0.13 ± --- 1 PLACE ± 0.25 ± --- 0 PLACE ± ±	DRAWN BY SVANG01 DATE 2015/12/08 CHECKED BY MWOLFE DATE 2015/12/08 APPROVED BY SMILLER DATE 2015/12/17	TITLE	IMPACT 4 PAIR HEADER LEFT GUIDED PDNI ASSEMBLY SALES DRAWING		
	ANGULAR ±1/2°	DRAFT WHERE APPLICABLE MUST REMAIN WITHIN DIMENSIONS	SEE TABLE	MATERIAL NO.	DOCUMENT NO.	SHEET NO. 2 OF 3	
	THIS DRAWING CONTAINS INFORMATION THAT IS PROPRIETARY TO MOLEX INCORPORATED AND SHOULD NOT BE USED WITHOUT WRITTEN PERMISSION						

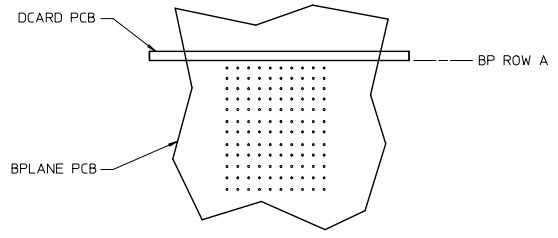

IMPACT 4 PAIR
BOARD RELATIONSHIPS

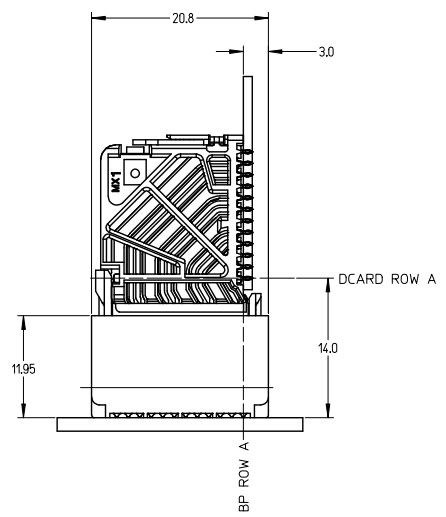
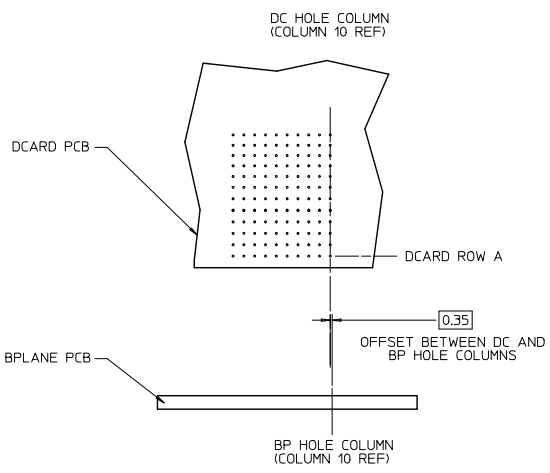

SEE SHEET 1 EC NO: UCP2016-2332 DRWNG: SVANG01 CHK: KMOLFE APPR: SMILLER	2015/12/08 2015/12/08 2015/12/17	QUALITY SYMBOLS ∇=0 ∇=0 ∇=0	GENERAL TOLERANCES (UNLESS SPECIFIED)		DIMENSION STYLE		SCALE	DESIGN UNITS	THIRD ANGLE PROJECTION	
			mm	INCH	MM ONLY		2:1	METRIC	⊕	
			4 PLACES ±	---	DRAWN BY	DATE	TITLE IMPACT 4 PAIR HEADER LEFT GUIDED PDNI ASSEMBLY SALES DRAWING molex MATERIAL NO. RSD-173428-002 DOCUMENT NO. SHEET NO. 3 OF 3			
			3 PLACES ±	---	CHECKED BY	DATE				
2 PLACES ±	0.13	APPROVED BY	DATE							
1 PLACE ±	0.25	SMILLER	2015/12/17							
0 PLACE ±	---			ANGULAR ±1/2°						
DRAFT WHERE APPLICABLE MUST REMAIN WITHIN DIMENSIONS				SEE TABLE						

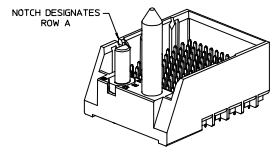
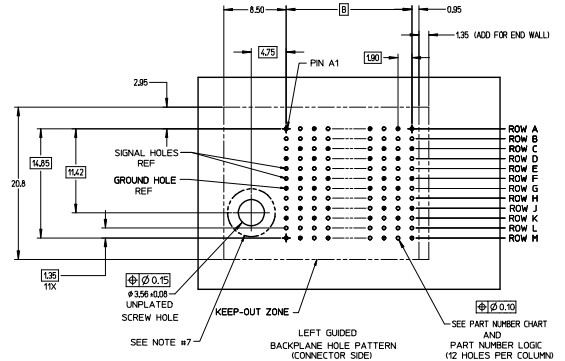
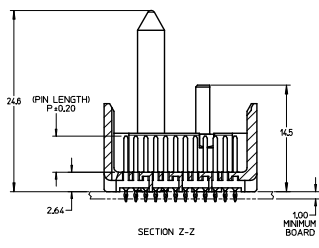
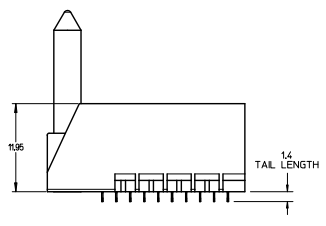
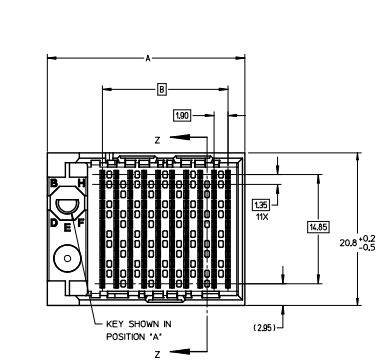

- NOTES:
- MATERIALS: HOUSING - LIQUID CRYSTAL POLYMER (LCP) GLASS-FILLED, UL94V-0
TERMINALS - HIGH PERFORMANCE COPPER ALLOY
 - FINISH: 30M MN GOLD IN CONTACT AREA, SELECTIVE TIN ON PCB TAILS, NICKEL OVERALL.
 - REFER TO MOLEX PRODUCT SPECIFICATION PS-76060-999 FOR PERFORMANCE SPECIFICATIONS AND ADDITIONAL PCB INFORMATION.
 - THIS PART CONFORMS TO CLASS B REQUIREMENTS OF MOLEX COSMETIC SPEC PS-45499-002.
 - PACKAGE PER: PK-70873-757.
 - SEE SHEETS 2 & 3 FOR PART NUMBERS AND BOARD RELATIONSHIPS.
 - FOR GROUNDED GUIDE PINS USE DIA. 3.56 +/-0.08 (IPTH) DIA. 3.66 (DRILL) AND DIA. 6.5 (PAD).
 - MATES WITH IMPACT DC SERIES NO. 76160.
 - KEEP OUT ZONE FOR BP HOUSING LENGTH INCLUDES AN ADDITIONAL 1.0MM TO ACCOMMODATE FOR SPACE REQUIRED BY DC FRONT HOUSING.
 - REFER TO MOLEX PCB ROUTING GUIDE AS-76060-990 FOR ANTI PAD AND ROUTING RECOMMENDATIONS.
 - CONNECTORS SUPPLIED WITH A 2-56 UNC-2A SCREW.
 - THESE DIMENSIONS REPRESENT THE AREA NEEDED TO ACCOMMODATE CONNECTOR INSERTION AND REPAIR ON THE PC BOARD. THIS IS REFERRED TO AS THE "CONNECTOR KEEP OUT ZONE" AND DOES NOT REPRESENT THE ACTUAL PERIMETER OF THE CONNECTOR. WHEN LAYING OUT THE PC BOARD FOR CONNECTORS STACKED TOGETHER, USE A 1.5mm PROGRESSION.

QUALITY SYMBOLS	GENERAL TOLERANCES (UNLESS SPECIFIED)		DIMENSION STYLE		SCALE	DESIGN UNITS	THIRD ANGLE PROJECTION
	mm	INCH	MM ONLY	DATE			
∇=0	4 PLACES ±---	±---	DRAWN BY MSANDBERG	2007/19/07	4:1	METRIC	IMPACT 4 PAIR HEADER LEFT GUIDED ASSEMBLY SALES DRAWING
∇=0	3 PLACES ±---	±---	CHECKED BY	DATE			
∇=0	2 PLACES ±0.13	±---	JLAURX	2007/19/07			
∇=0	1 PLACE ±0.25	±---	APPROVED BY	DATE			
∇=0	0 PLACE ±	±---	JLAURX	2010/11/15			
ANGULAR ±1/2°			MATERIAL NR.		DOCUMENT NO.		SHEET NO.
DRAFT WHERE APPLICABLE MUST REMAIN WITHIN DIMENSIONS			SEE TABLE		SD-76155-002		1 OF 3
THIS DRAWING CONTAINS INFORMATION THAT IS PROPRIETARY TO MOLEX INCORPORATED AND SHOULD NOT BE USED WITHOUT WRITTEN PERMISSION							

PART NUMBER TABLE

MATERIAL NUMBER	# OF COLUMNS	# OF DIFF PAIR	DIM 'A'	DIM 'B'	GUIDE LEFT END WALL OPTION
76155-3**	6	24	19.3	9.50	
76155-8**	8	32	23.1	13.30	
76155-1**	10	40	26.9	17.10	
76155-6**	16	64	38.3	28.50	

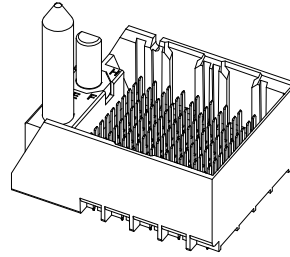

GUIDE LEFT
END WALL
OPTION

MATERIAL NUMBER	# OF COLUMNS	# OF DIFF PAIR	DIM 'A'	DIM 'B'	GUIDE LEFT OPEN WALL OPTION
76155-3**	6	24	17.9	9.50	
76155-8**	8	32	21.7	13.30	
76155-1**	10	40	25.5	17.10	
76155-6**	16	64	36.9	28.50	

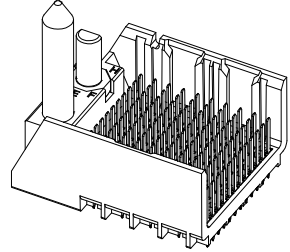

GUIDE LEFT
OPEN WALL
OPTION

PART NUMBER LOGIC

76155-****

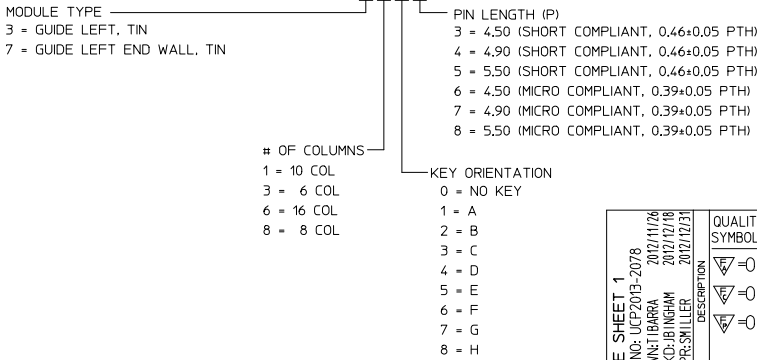

SEE SHEET 1 EC NO: UCP2015-2078 DRAWN: TIBARRA 2012/11/28 CHKD: BINGHAM 2012/12/18 APPR: SMILLER 2012/12/31	QUALITY SYMBOLS ▽=0 ▽=0 ▽=0	GENERAL TOLERANCES (UNLESS SPECIFIED)		DIMENSION STYLE MM ONLY		SCALE 3:1	DESIGN UNITS METRIC	THIRD ANGLE PROJECTION	
		4 PLACES ± --- ± ---	3 PLACES ± --- ± ---	DRAWN BY MSANDBERG	DATE 2007/19/07	TITLE IMPACT 4 PAIR HEADER LEFT GUIDED ASSEMBLY SALES DRAWING			
		2 PLACES ± 0.13 ± ---	1 PLACE ± 0.25 ± ---	CHECKED BY JLAURX	DATE 2007/19/07				
		0 PLACE ± --- ± ---	ANGULAR ± 1/2°	APPROVED BY JLAURX	DATE 2010/11/15				

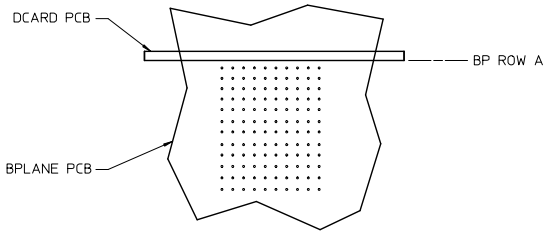

IMPACT 4 PAIR
BOARD RELATIONSHIPS

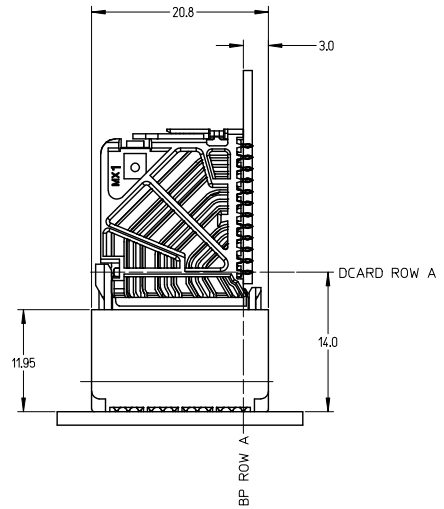
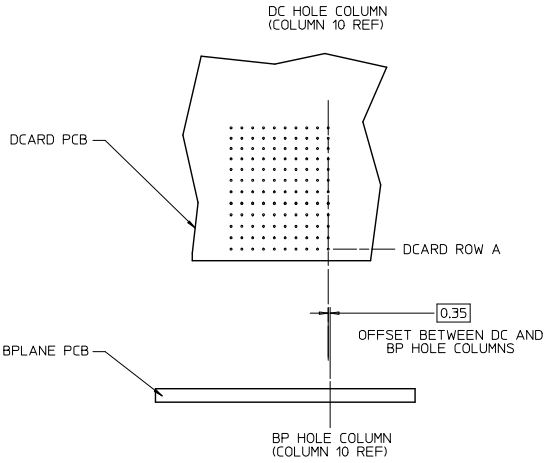

SEE SHEET 1 EC NO: UCP2013-2078 DRAWN: IBARRA 2012/11/28 CHKD: B INGHAM 2012/12/18 APPR: MILLER 2012/12/31	QUALITY SYMBOLS ∇=0 ∇=0 ∇=0	GENERAL TOLERANCES (UNLESS SPECIFIED)		DIMENSION STYLE MM ONLY		SCALE 2:1	DESIGN UNITS METRIC	THIRD ANGLE PROJECTION	
			mm	INCH	DRAWN BY MSANDBERG	DATE 2007/19/07	TITLE IMPACT 4 PAIR HEADER LEFT GUIDED ASSEMBLY SALES DRAWING molex DOCUMENT NO. SD-76155-002 SHEET NO. 3 OF 3		
		4 PLACES ±	---	---	CHECKED BY JLAURX	DATE 2007/19/07			
		3 PLACES ±	---	---	APPROVED BY JLAURX	DATE 2010/11/15			
2 PLACES ±	0.13	---							
1 PLACE ±	0.25	---			ANGULAR ±1/2°				
0 PLACE ±					DRAFT WHERE APPLICABLE MUST REMAIN WITHIN DIMENSIONS				
				SEE TABLE					
				MATERIAL NO.					
				SIZE C		THIS DRAWING CONTAINS INFORMATION THAT IS PROPRIETARY TO MOLEX INCORPORATED AND SHOULD NOT BE USED WITHOUT WRITTEN PERMISSION			