



**Distributor of Molex Connector Corporation: Excellent Integrated System Limited**  
Datasheet of 0872641253 - Connector Receptacle 12 Position 0.079" (2.00mm) Gold Through  
Hole, Right Angle

Contact us: [sales@integrated-circuit.com](mailto:sales@integrated-circuit.com) Website: [www.integrated-circuit.com](http://www.integrated-circuit.com)

---

## **Excellent Integrated System Limited**

Stocking Distributor

Click to view price, real time Inventory, Delivery & Lifecycle Information:

[Molex Connector Corporation](#)  
[0872641253](#)

For any questions, you can email us directly:  
[sales@integrated-circuit.com](mailto:sales@integrated-circuit.com)

Contact us: sales@integrated-circuit.com Website: www.integrated-circuit.com

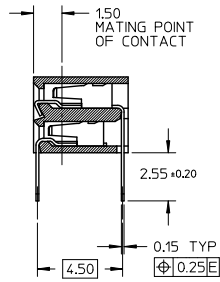
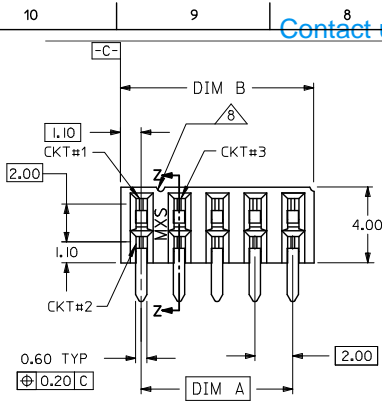

PART NO. LEGEND

87264- \* \* 5 \*  
CIRCUIT SIZE PLATING  
POST-PLATED

- 2 - 0.38um/15uin MIN. GOLD PLATE IN SELECTED AREA AND 2.54um/100uin MIN. TIN IN SELECTED AREA OVER 1.27um/50uin NICKEL OVERALL (IN TUBE).
- 3 - 0.76um/30uin MIN. GOLD PLATE IN SELECTED AREA AND 2.54um/100uin MIN. TIN IN SELECTED AREA OVER 1.27um/50uin NICKEL OVERALL (IN TUBE).
- 4 - 0.05-0.25um/2-10uin GOLD PLATE IN SELECTED AREA AND 2.54um/100uin MIN. TIN IN SELECTED AREA OVER 1.27um/50uin NICKEL OVERALL (IN TUBE).
- 8 - 0.38um/15uin MIN. GOLD PLATE IN SELECTED AREA AND 2.54um/100uin MIN. TIN IN SELECTED AREA OVER 1.27um/50uin NICKEL OVERALL (IN TAPE/REEL)
- 9 - 0.76um/30uin MIN. GOLD PLATE IN SELECTED AREA AND 2.54um/100uin MIN. TIN IN SELECTED AREA OVER 1.27um/50uin NICKEL OVERALL (IN TAPE/REEL)
- 5 - 0.05-0.25um/2-10uin GOLD PLATE IN SELECTED AREA AND 2.54um/100uin MIN. TIN IN SELECTED AREA OVER 1.27um/50uin NICKEL OVERALL (IN TAPE/REEL)

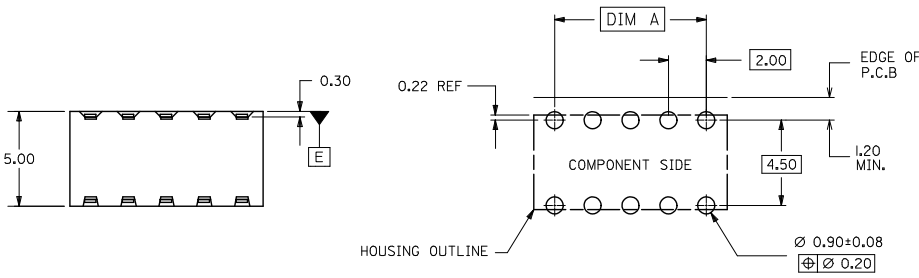

RECOMMENDED P.C. BOARD LAYOUT

NOTES:

1. IO CIRCUIT SIZE SHOWN FOR ILLUSTRATION ONLY. SEE CHART FOR AVAILABLE PART SIZES.
2. PLATING FINISH: TERMINAL - AS PER LEGEND
3. RECOMMENDED PC BOARD THICKNESS IS 1.60 ± 0.10mm.
4. PRODUCT SPECIFICATION PS-78264 APPLIES.
5. PART IS MATEABLE TO ALL MILLI-GRID HEADERS WITH MATING PIN LENGTH BETWEEN 2.50mm AND 4.20mm.
6. TAPE & REEL OPTION IS SHOWN ON SHT 3 WITH 8 CKT ILLUSTRATION
7. PARTS SHALL BE PACKED IN MOISTURE BARRIER BAG.
8. FIRST CIRCUIT TO BE IDENTIFIED BY A NOTCH ACROSS TOP OF HOUSING AND IS LOCATED BETWEEN CIRCUIT 1&3 AS SHOWN.

ADD NOTE 8 EC NO: S2016-0587 DRAWN: SICHONG CHKD: GGH APPR: KILLIM 2015/12/29 2016/01/11 2016/01/12	QUALITY SYMBOLS ▽=0 ▽=0	GENERAL TOLERANCES (UNLESS SPECIFIED)		DIMENSION STYLE MM ONLY		SCALE NTS	DESIGN UNITS METRIC	THIRD ANGLE PROJECTION	
		4 PLACES ± --- ± ---	3 PLACES ± --- ± ---	DRAWN BY JWAN	DATE 1992/02/25	TITLE MGRID, 2MM DUAL ROW HDR. SIDE ENTRY RECEPTACLE T/H			
		2 PLACES ± 0.2 ± ---	1 PLACE ± --- ± ---	CHECKED BY MLAI	DATE 1992/02/25	MOLEX INCORPORATED			
		ANGULAR ± 3 °		APPROVED BY RWONG	DATE 1992/02/25	MATERIAL NO. SEE TABLE		DOCUMENT NO. SD-87264-**-50	SHEET NO. 1 OF 3
DRAFT WHERE APPLICABLE MUST REMAIN WITHIN DIMENSIONS		THIS DRAWING CONTAINS INFORMATION THAT IS PROPRIETARY TO MOLEX INCORPORATED AND SHOULD NOT BE USED WITHOUT WRITTEN PERMISSION							

Contact us: [sales@integrated-circuit.com](mailto:sales@integrated-circuit.com) Website: [www.integrated-circuit.com](http://www.integrated-circuit.com)

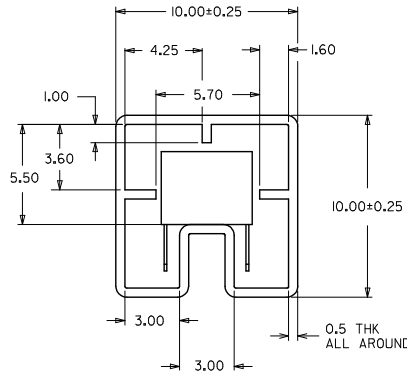
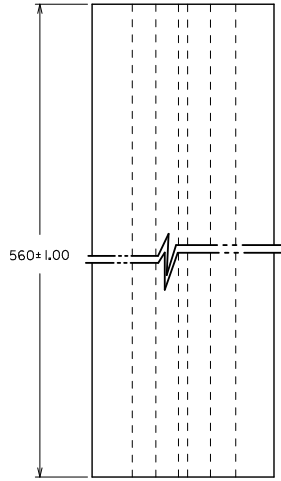

PART IN TUBE ORIENTATION.

PART NUMBER 0.38um GOLD PLATING	PART NUMBER 0.76um GOLD PLATING	CKT. SIZE	DIM A	DIM B
87264-0652	87264-0653	6	4.00	6.20
87264-0852	87264-0853	8	6.00	8.20
87264-1052	87264-1053	10	8.00	10.20
87264-1252	87264-1253	12	10.00	12.20
87264-1452	87264-1453	14	12.00	14.20
87264-1652	87264-1653	16	14.00	16.20
87264-1852	87264-1853	18	16.00	18.20
87264-2052	87264-2053	20	18.00	20.20
87264-2252	87264-2253	22	20.00	22.20
87264-2452	87264-2453	24	22.00	24.20
87264-2652	87264-2653	26	24.00	26.20
87264-2852	87264-2853	28	26.00	28.20
87264-3052	87264-3053	30	28.00	30.20
87264-3252	87264-3253	32	30.00	32.20
87264-3452	87264-3453	34	32.00	34.20
87264-3652	87264-3653	36	34.00	36.20
87264-3852	87264-3853	38	36.00	38.20
87264-4052	87264-4053	40	38.00	40.20
87264-4252	87264-4253	42	40.00	42.20
87264-4452	87264-4453	44	42.00	44.20
87264-4652	87264-4653	46	44.00	46.20
87264-4852	87264-4853	48	46.00	48.20
87264-5052	87264-5053	50	48.00	50.20

<b>ADD NOTE 8</b> EC NO: S2016-0587 DRAWN: SICHONG CHKD: GGH APPR: KILLIM 2015/12/29 2016/01/11 2016/01/12	QUALITY SYMBOLS	GENERAL TOLERANCES (UNLESS SPECIFIED)	DIMENSION STYLE	SCALE	DESIGN UNITS	THIRD ANGLE PROJECTION
	▽=0 ▽=0	4 PLACES ± --- ± --- 3 PLACES ± --- ± --- 2 PLACES ± 0.2 ± --- 1 PLACE ± --- ± --- ANGULAR ± 3 °	MM ONLY	NTS	METRIC	<input checked="" type="checkbox"/> THIRD ANGLE <input type="checkbox"/> PROJECTION
	DRAWN BY: JWAN CHECKED BY: MLAI APPROVED BY: RWONG DATE: 1992/02/25 DATE: 1992/02/25 DATE: 1992/02/25	MATERIAL NO. <b>SEE TABLE</b>	TITLE MGRID, 2MM DUAL ROW HDR. SIDE ENTRY RECEPTACLE T/H	MOLEX INCORPORATED	DOCUMENT NO. SD-87264-**50	SHEET NO. 2 OF 3
	DRAFT WHERE APPLICABLE MUST REMAIN WITHIN DIMENSIONS	SIZE A3	THIS DRAWING CONTAINS INFORMATION THAT IS PROPRIETARY TO MOLEX INCORPORATED AND SHOULD NOT BE USED WITHOUT WRITTEN PERMISSION			

Contact us: [sales@integrated-circuit.com](mailto:sales@integrated-circuit.com) Website: [www.integrated-circuit.com](http://www.integrated-circuit.com)

PART NUMBER 0.38um GOLD PLATING (IN TAPE/REEL)	PART NUMBER 0.76um GOLD PLATING (IN TAPE/REEL)	CKT SIZE	DIM W	DIM F	DIM Bo
87264-0858	87264-0859	8	24.00	11.50	8.80

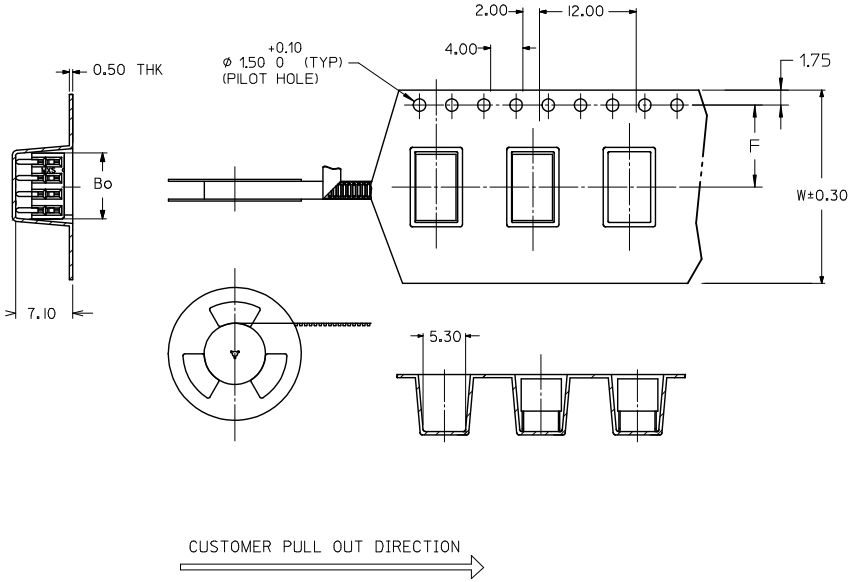

NOTES:

1. LEADER AND TRAILER TAPE

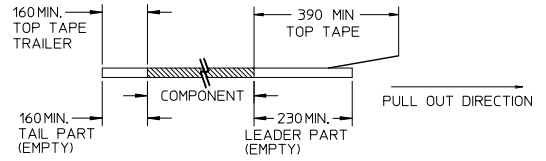

2. PEELING OFF FORCE OF THE TOP TAPE: 20-80gf.  
(PEELING DIRECTION AS SHOWN IN FOLLOWING FIGURE)

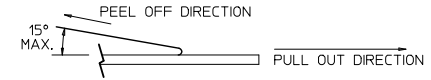

3. PACKAGING STANDARD IS AS PER EIA-481.

4. TAPE & REEL QUANTITY = 600PCS/REEL

<b>ADD NOTE 8</b> EC NO: S2016-0587 DRAWN: SICHONG CHKD: GOH APPR: KILLIM 2015/12/29 2016/01/11 2016/01/12	QUALITY SYMBOLS	GENERAL TOLERANCES (UNLESS SPECIFIED)	DIMENSION STYLE	SCALE	DESIGN UNITS	THIRD ANGLE PROJECTION
	▼=0 ▽=0	mm INCH 4 PLACES ± --- ± --- 3 PLACES ± --- ± --- 2 PLACES ± 0.2 ± --- 1 PLACE ± --- ± --- ANGULAR ± 3 °	MM ONLY	NTS	METRIC	MGRID, 2MM DUAL ROW HDR. SIDE ENTRY RECEPTACLE T/H
	DRAFT WHERE APPLICABLE MUST REMAIN WITHIN DIMENSIONS	DRAWN BY: JWAN CHECKED BY: MLAI APPROVED BY: RWONG DATE: 1992/02/25 DATE: 1992/02/25 DATE: 1992/02/25	MATERIAL NO. SEE TABLE	DOCUMENT NO. SD-87264-**-50	MOLEX INCORPORATED	SHEET NO. 3 OF 3
	SIZE A3	THIS DRAWING CONTAINS INFORMATION THAT IS PROPRIETARY TO MOLEX INCORPORATED AND SHOULD NOT BE USED WITHOUT WRITTEN PERMISSION				